



## **Alliant Energy - Gas Service Manual**

### **Chapter 3 – Metering Facility Location and Clearances**

**Issued:** 2023

**Supersedes:** 2019

---

#### **A. LOCATION AND PROTECTION OF COMPANY METERING FACILITIES**

1. The Company will install, own and maintain its own metering and control equipment on the customer's premises. Gas metering equipment will typically be installed adjacent to the customer's building or facility at a location selected by the Company after consulting with the customer.
2. Adequate space shall be provided at the meter location for easy access to the meter, regulator, relief valve, and manifold piping without cost to the Company. Company personnel shall have free access to such equipment at all reasonable times. Refer to GSM Chapter 4 "Gas Meter Connections" for space requirements.
3. The gas meter, regulator, and relief valve shall be located outside. In a situation where the meter set, regulator, and relief valve cannot physically be located outside, the Company shall determine if an acceptable inside location is available.
4. If an inside meter set requires dual stage regulation, the first stage regulator must be located outside and any inside regulator and relief valve must be properly vented outside to the atmosphere. Meters and regulators located inside shall be placed as near as practical to the point of service line entrance.
5. When selecting a metering location, consideration must be given to protecting the meter set from damage by external forces. Examples of such forces include, but are not limited to, motor vehicles, excessive vibration, falling and/or an accumulation of ice or snow, and pedestrian traffic.
6. Any meter set that is installed adjacent to a driveway; roadway or parking lot must be located and protected in such a manner that the potential for being damaged or covered during snow removal is minimized. The Company will provide vehicular protection deemed necessary at the time of initial service installation. Changes made after the initial service installation that require vehicular protection shall be at the customer's expense.
7. Fire pits shall not be installed over buried gas piping. Fire pits installed over Company buried gas piping shall be relocated at the customer's expense.



8. The Company may refuse or disconnect service to any outside metering facility installation that, in the judgment of the Company, does not meet any of the following criteria:
- Outside metering facilities shall be located in such a way that any escaping gas will flow freely into the atmosphere and away from any opening in the building.
  - Outside metering facilities shall be in a location that would allow the Company safe and reliable access.
  - Outside metering facilities shall be in a location where the meter set will not be subjected to excessive corrosion or vibration.
  - Outside metering facilities shall be in a location where excessive ice, water or condensation will not build-up on the meter set or relief vent. The customer may be charged for meter set replacement if damage occurs. An outage is typically required to replace any damaged equipment.
  - If protection is not provided for metering facilities by adequate roof overhang, the customer shall construct a protective shield or the metering facility location shall be moved to a safe area. A typical adequate roof overhang shall extend a minimum of 18 in-24 in out from the face of the wall where the meter set is located.

Below is a recommended design for a protective shield:

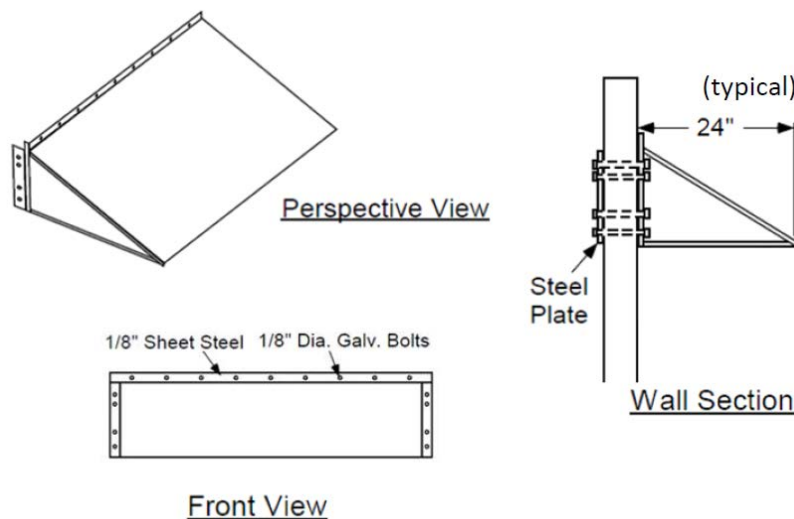

Notes:

- This design is a recommendation. Installed protective shield overhang and width shall be adequate to protect Company facilities.
- Steel to be primed and painted with rust resistant paint.
- Shield shall be capable of supporting 50 pounds.
- Shield may be constructed of steel, treated wood or masonry. Thin sheet metal (tin) is not acceptable.
- Shield to be located as to not be a “head bumping” hazard.



---

## B. GAS METER SET CLEARANCES

1. Minimum gas meter set clearances are based on code requirements, Company standards, and industry best practices. Clearances based on Company standards shall apply to all new and relocated gas meter set installations.
2. Required and recommended minimum clearances are intended to provide for safe, accessible, and protected placement of a new or relocated meter set installation. Consider the migration of escaping gas when determining if clearances should be extended beyond the minimum recommended or required clearances.
3. All clearance measurements are from the regulator relief vent or, in the case of a commercial/industrial meter set, from the relief valve outlet point, if so equipped. Refer also to the clearance illustrations on the following pages.

### **Required** Clearances for Acceptable Meter Set Placement:

- a) Minimum 3 feet radial clearance from any source of ignition (NFPA 54, Section 5.14).
- b) Minimum 5 feet horizontal clearance from a pad mounted transformer.
- c) Minimum 10 feet radial clearance from all non-combustion powered building air intakes including window or wall-mounted air conditioning units and air exchanger conduits (Iowa Mechanical Code, 401.4, Wisconsin Mechanical Code, 401.4).

### **Recommended** Clearances for Acceptable Meter Set Placement:

- d) Minimum 3 feet radial clearance from all doors and operable windows.
- e) Minimum 3 feet radial clearance from communications box.
- f) Minimum 3 feet radial clearance from electric motors and electrical outlets.
- g) Minimum 3 feet radial clearance from an electric meter.
- h) Minimum 3 feet radial clearance from water meter remote readers.
- i) Minimum 3 feet horizontal clearance from all water spigots.
- j) Minimum 3 feet horizontal clearance from all combustion air intakes.
- k) Minimum 3 feet horizontal clearance from openings of all exhaust vents.
- l) Minimum 3 feet horizontal clearance from sealed central air conditioning or heat pump units (including electric box).
- m) Minimum 6 feet vertical clearance from decks, porches, balconies, and stairs.
- n) Minimum 6 feet vertical clearance from soffit vent opening.

**(Refer to the clearance illustrations on the following pages)**



**GAS METER SET CLEARANCES - Continued**

**RADIAL DISTANCE REQUIRED**

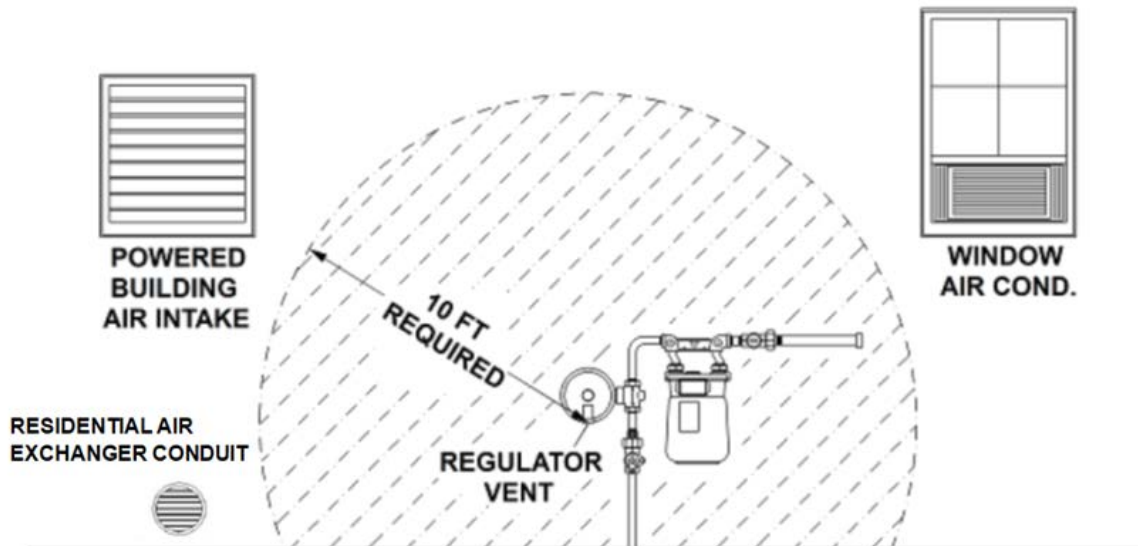

**RADIAL DISTANCE FOR PROPER CLEARANCE**

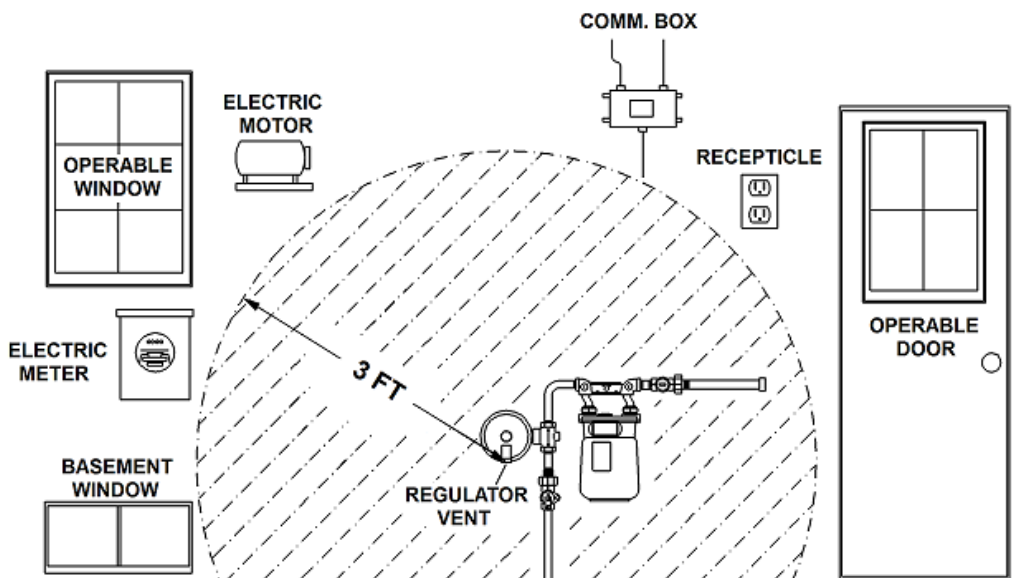

**NOTE: All clearances measured from outlet of regulator relief vent.**



## GAS METER SET CLEARANCES – Continued

### HORIZONTAL DISTANCE

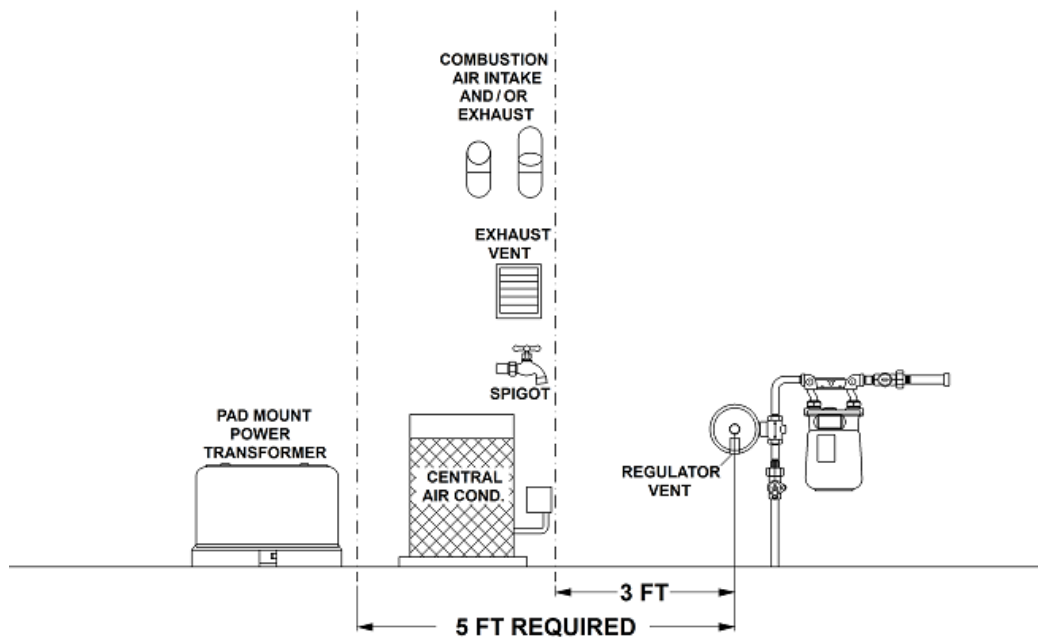

### VERTICAL DISTANCE

#### SOFFIT VENT OPENING

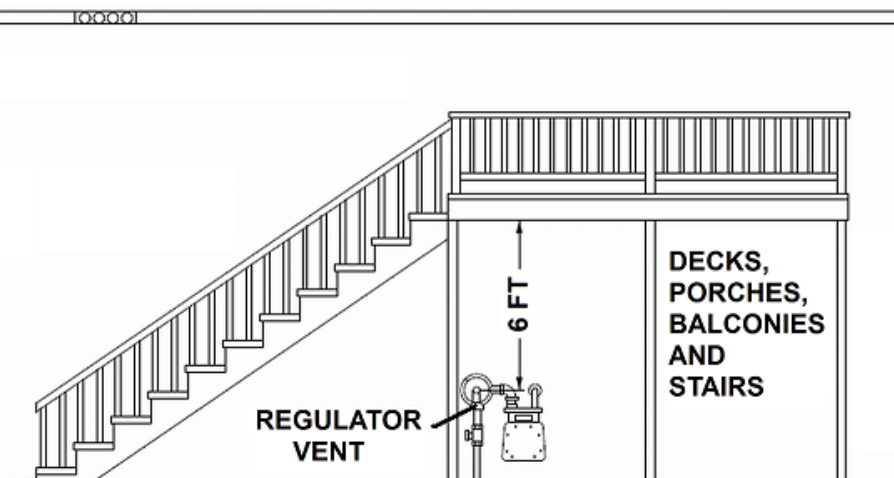

**NOTE: All clearances measured from outlet of regulator relief vent.**