

2024

# Electric Service Rules

- GENERAL INFORMATION
- TEMPORARY SERVICES
- OVERHEAD SERVICES
- UNDERGROUND SERVICES
- DISTRIBUTED GENERATION
- METERING
- HUD MANUFACTURED HOMES
- FARM SERVICES
- UTILITY/CATV SERVICES
- PRIMARY SERVICES
- SPECIAL SERVICES AND MOTORS
- OPTIONAL STANDBY GENERATION
- CLEARANCES
- GROUNDING AND BONDING
- ELECTRIC VEHICLES



**Updates to this e-manual may be necessary  
throughout the year. Please see  
[www.alliantenergy.com/servicemanuals](http://www.alliantenergy.com/servicemanuals)  
for the most up-to-date information.**



**Call Before You Dig**

**DIGGERS HOTLINE**, Telephone Numbers, Alliant Energy Web Site Information & Cable Locating Services

**ALLIANT ENERGY IP&L/WP&L TELEPHONE NUMBERS**

Electric Service: 1-800-862-6222 or 1-800-ALLIANT  
Outage Reporting: 1-877-740-5050 or 1-800-ALLIANT

**PRE-EXCAVATION TELEPHONE NUMBERS**

Pre-Excavation Call Number All Areas - 811  
Iowa – Iowa One Call: 1-800-292-8989  
Wisconsin – Diggers Hotline: 1-800-242-8511

**ALLIANT ENERGY WEBSITE**

Key in Web Site  
[www.alliantenergy.com/service manuals](http://www.alliantenergy.com/service manuals)

**Call Before You Dig**





TABLE OF CONTENTS - ESR Revision Date: January 2021

<b>CHAPTER 1 – GENERAL INFORMATION</b>	<b>Page</b>
100. <a href="#">General</a> .....	1-1
101. <a href="#">Purpose</a> .....	1-1
102. <a href="#">Scope</a> .....	1-1
103. <a href="#">Codes and Rules</a> .....	1-1
104. <a href="#">Word Application</a> .....	1-2
105. <a href="#">Continuity of Service</a> .....	1-2
106. <a href="#">Point of Service</a> .....	1-3
107. <a href="#">Application for Service</a> .....	1-3
108. <a href="#">Service Voltages and Maximum Amperage</a> .....	1-4
109. <a href="#">Number of Services</a> .....	1-5
110. <a href="#">Short Circuit Duty Requirements</a> .....	1-10
111. <a href="#">Inspections and Maintenance</a> .....	1-12
112. <a href="#">Service Connections</a> .....	1-12
113. <a href="#">Identification of Conductors</a> .....	1-12
114. <a href="#">Changes to Existing Service-Entrance Equipment</a> .....	1-12
115. <a href="#">Alliant Energy Equipment on Customer Premises</a> .....	1-13
116. <a href="#">Capacity</a> .....	1-13
117. <a href="#">Sequence of Disconnecting Service and Meter</a> .....	1-14
118. <a href="#">Customer Installation</a> .....	1-14
119. <a href="#">Communication Tower Installation</a> .....	1-15
<b>CHAPTER 2 - TEMPORARY SERVICE</b>	
200. <a href="#">General</a> .....	2-1
201. <a href="#">Overhead Temp Ser, 1PH, 3-Wire, 120/240V or 120/208, 200A Max</a> .....	2-2 & 2-3
202. <a href="#">Underground Temp./Perm. Service, 1PH, 3-Wire, 120/240V, 200A Max</a> .....	2-4
203. <a href="#">Underground Temp Ser, 1PH, 3-Wire, 120/240V or 120/208, 200A Max</a> .....	2-5
204. <a href="#">Underground Temp Ser, 1PH, 3-Wire, 120/240V or 120/208, 200A Max</a> .....	2-6
205. <a href="#">Large Temporary Service, 1PH or 3PH</a> .....	2-7





**ELECTRIC SERVICE RULES**

**Issued Jan 2024**

---

**CHAPTER 3 – OVERHEAD SECONDARY SERVICE Page**

300. [Scope](#) ..... 3-1

301. [Attachment of Service Drops](#)..... 3-1

302. [Service Riser Requirements](#)..... 3-1

303. [Service Mast Construction](#) ..... 3-2

304. [Service Mast Installation](#) ..... 3-3

305. [Wall or Through-The-Roof Installation](#) ..... 3-4

306. [Pole Mounted Service Entrance – Optional Construction](#) ..... 3-5

**CHAPTER 4 – UNDERGROUND SECONDARY SERVICE**

400. [Scope](#) ..... 4-1

401. [General Information](#)..... 4-1

402. [Sizing Underground Facilities](#)..... 4-1

403. [Location of Alliant Energy Secondary Voltage Cables](#) ..... 4-2

404. [Underground Service Installations](#) ..... 4-2

405. [Outdoor Meter Socket, 1PH &r 3PH](#)..... 4-4

406. [Outdoor Meter Pedestal Service, Single or Duplex, 1PH & 3PH](#) ..... 4-5

407. [Rigid Conduit](#)..... 4-6

408. [Concrete Pad Specifications and Layout for 1PH & 3PH, Pad-Mount Trf](#) ..... 4-9

409. [Concrete Specifications and Layout for Foundation Wall for 3PH, PM Trf](#)..... 4-12

410. [Concrete Pad Specifications & Layout for 3PH, PM Trf and Metering TC](#) ..... 4-14

411. [Concrete Pad Specifications & Layout for Customer Owned Pad Metering/ TC](#) .... 4-16

412. [Box Pad Specification for 3PH, Pad-Mount Transformers](#) ..... 4-18

413. [Box Pad Specification for 1PH, Pad-Mount Transformers](#) ..... 4-19



ELECTRIC SERVICE RULES

Issued Jan 2024

<b>CHAPTER 5 – DISTRIBUTED GENERATION</b>	<b>Page</b>
500. <a href="#">Scope</a> .....	5-1
501. <a href="#">Permission to Interconnect</a> .....	5-1
502. <a href="#">Technical Information</a> .....	5-1
503. <a href="#">Metering Equipment</a> .....	5-2
504. <a href="#">Alliant Energy Distribution System</a> .....	5-2
505. <a href="#">Primary Metering Customers with DG</a> .....	5-2
506. <a href="#">Delta Connected Customers with DG</a> .....	5-2
507. <a href="#">Optional Standby Generator Used with DG</a> .....	5-2
508. <a href="#">Electrically Isolated Arrays</a> .....	5-2
509. <a href="#">Labeling Requirements</a> .....	5-3
510. <a href="#">Point of Interconnection</a> .....	5-3
511. <a href="#">Interconnection Disconnect Switch (Disconnect Device) Requirements</a> .....	5-4
512. <a href="#">Battery Energy Storage Systems</a> .....	5-5
513-525 <a href="#">Drawings</a> .....	5-5
513. <a href="#">1PH/3PH, Self-Contained, Single Lug Main</a> .....	5-6
514. <a href="#">1PH/3PH, Self-Contained, Single Lug UL Listed Gutter, or UL Listed Termination Box</a> .....	5-6
515. <a href="#">1PH/3PH, Self-Contained, Approved Alternate Energy Meter Socket, 200 Amp Main, 60-70 Amp DG Breaker (See ESE 106A)</a> .....	5-7
516. <a href="#">1PH/3PH, Self-Contained, Approved Dual Lug Meter Socket (See ESE 106B)</a> .....	5-7
517. <a href="#">1PH/3PH, Self-Contained, Single Lug Remote Building With DG &gt; 30' From Meter</a> .....	5-8
518. <a href="#">1PH/3PH, Self-Contained, Dual Lug Remote Building With DG &gt; 30' From Meter (See ESE E106B)</a> .....	5-9
519. <a href="#">1PH/3PH, Metering Transformer Cabinet</a> .....	5-8
520. <a href="#">1PH/3PH, Metering Transformer Cabinet, With Available Lugs in Metering Transformer Cabinet</a> .....	5-9
521. <a href="#">1PH/3PH, Metering Transformer Cabinet, Single Lug, UL Listed Bussed Gutter or UL Listed Termination Box</a> .....	5-10
522. <a href="#">1PH/3PH, Metering Transformer Cabinet, Remote Building With DG &gt; 30' From Meter</a> .....	5-11
523. <a href="#">1PH/3PH, Metering Transformer Cabinet, Remote Building With DG &gt; 30' From Meter</a> .....	5-11
524. <a href="#">1PH/3PH, Self-Contained, Single Lug + Battery Energy Storage System (Entire Service Backup)</a> .....	5-12
525. <a href="#">1PH/3PH, Self-Contained, Single Lug + Battery Energy Storage System Load Panel</a> ..	5-12



**ELECTRIC SERVICE RULES**

**Issued Jan 2024**

**CHAPTER 6 – METERING Page**

600.	<a href="#"><u>Metering Facilities.....</u></a>	<a href="#"><u>6-1</u></a>
601.	<a href="#"><u>Location of Meters .....</u></a>	<a href="#"><u>6-1</u></a>
602.	<a href="#"><u>Metering Installations.....</u></a>	<a href="#"><u>6-2</u></a>
603.	<a href="#"><u>Identification of Meters.....</u></a>	<a href="#"><u>6-3</u></a>
604.	<a href="#"><u>Meter Seals .....</u></a>	<a href="#"><u>6-3</u></a>
605.	<a href="#"><u>Separation of Metered and Un-Metered Conductors.....</u></a>	<a href="#"><u>6-3</u></a>
606.	<a href="#"><u>Clearance Requirements for Metering Equipment .....</u></a>	<a href="#"><u>6-4</u></a>
607.	<a href="#"><u>Meter Socket Requirements .....</u></a>	<a href="#"><u>6-6</u></a>
608.	<a href="#"><u>Metering Equipment Shield.....</u></a>	<a href="#"><u>6-7</u></a>
609.	<a href="#"><u>Outdoor Free-Standing (Field-Built) Meter Structures .....</u></a>	<a href="#"><u>6-8</u></a>
610.	<a href="#"><u>Meter Socket Types.....</u></a>	<a href="#"><u>6-11</u></a>
611.	<a href="#"><u>Self-Contained Group &amp; Modular Metering, 200A Max .....</u></a>	<a href="#"><u>6-13</u></a>
612.	<a href="#"><u>Metering Transformer Cabinet Installations .....</u></a>	<a href="#"><u>6-18</u></a>
613.	<a href="#"><u>Combined Self-Contained Group &amp; Modular &amp; Metering Trf Cabinet Installs .....</u></a>	<a href="#"><u>6-25</u></a>

**CHAPTER 7 – HUD MANUFACTURED HOMES**

700.	<a href="#"><u>Scope .....</u></a>	<a href="#"><u>7-1</u></a>
701.	<a href="#"><u>General Requirements.....</u></a>	<a href="#"><u>7-1</u></a>
702.	<a href="#"><u>Definitions.....</u></a>	<a href="#"><u>7-2</u></a>
703.	<a href="#"><u>Mobile/Manufactured Home Courts .....</u></a>	<a href="#"><u>7-4</u></a>
704.	<a href="#"><u>Service Entrance Pedestal for Manufactured Homes, Underground .....</u></a>	<a href="#"><u>7-5</u></a>
705.	<a href="#"><u>Field Built Service Entrance for Manufactured Homes, Overhead.....</u></a>	<a href="#"><u>7-6</u></a>
706.	<a href="#"><u>Field Built Service Entrance for Manufactured Homes, Underground .....</u></a>	<a href="#"><u>7-8</u></a>
707.	<a href="#"><u>Manufactured Home Service Pedestal, Mounted on Frost Wall .....</u></a>	<a href="#"><u>7-10</u></a>
708.	<a href="#"><u>Manufactured Home Service Pedestal, Mounted on Full Basement.....</u></a>	<a href="#"><u>7-11</u></a>



**ELECTRIC SERVICE RULES**

**Issued Jan 2024**

---

<b>CHAPTER 8 – FARM SERVICE</b>	<b>Page</b>
800. <a href="#">Scope</a> .....	8-1
801. <a href="#">Non-Farm Services</a> .....	8-1
802. <a href="#">Farm Service Yard Pole or Structure</a> .....	8-1
803. <a href="#">Key-Interlock Systems - Farm Standby-Generation</a> .....	8-3
804. <a href="#">Service to Farm w/Disconnect and Overcurrent Protection</a> .....	8-4
805. <a href="#">UG Service to Farm from Pad-mount Trf &amp; Metering Transformer Cabinet</a> .....	8-9
806. <a href="#">OH Service to Farm w/Disconnect and Metering Transformer Cabinet</a> .....	8-10
807. <a href="#">OH Service to Farm Yard Pole with Pole Top Transfer Switch</a> .....	8-16
 <b>CHAPTER 9 – UTILITY/CATV</b>	
900. <a href="#">General</a> .....	9-1
901. <a href="#">Utility/CATV Pole-Mount Service, 120/240 Volt, Single-Phase, 200A Max</a> .....	9-3
902. <a href="#">Utility/CATV Underground Service, 120/240 Volt, Single-Phase, 200A Max</a> .....	9-5
903. <a href="#">Connect America - Field-built Structures</a> .....	9-7
904. <a href="#">Non-Metered Holiday Lighting (Where Permitted)</a> .....	9-9
905. <a href="#">Metered Holiday Lighting (Where Permitted)</a> .....	9-10
906. <a href="#">Make Ready NESC Minimum Requirements for Street Lighting</a> .....	9-11
907. <a href="#">Small Cell Equipment Installation</a> .....	9-12
 <b>CHAPTER 10 – PRIMARY SERVICES</b>	
1000. <a href="#">General</a> .....	10-1
1001. <a href="#">Underground Primary Service to Metering Enclosure</a> .....	10-4
1002. <a href="#">Underground Primary Service to Switchgear</a> .....	10-6
1003. <a href="#">Overhead Primary Service</a> .....	10-8
 <b>CHAPTER 11 – SPECIAL EQUIPMENT AND MOTORS</b>	
1100. <a href="#">Scope</a> .....	11-1
1101. <a href="#">Service Impairing Equipment</a> .....	11-1
1102. <a href="#">Phase Balance</a> .....	11-1
1103. <a href="#">Protection and Control</a> .....	11-2
1104. <a href="#">Motor Specifications</a> .....	11-2
1105. <a href="#">Maximum Permitted HP for Single-Phase Motors</a> .....	11-3
1106. <a href="#">Permitted Maximum HP for Three-Phase Motors</a> .....	11-4
1107. <a href="#">Permitted Maximum Amps for Motors</a> .....	11-4





**ELECTRIC SERVICE RULES**

**Issued Jan 2024**

**CHAPTER 12 – OPTIONAL STANDBY GENERATION Page**

1200. <a href="#">Scope</a> .....	12-1
1201. <a href="#">Safety</a> .....	12-1
1202. <a href="#">Transfer System Requirements</a> .....	12-1
1203. <a href="#">Transfer Switch Options</a> .....	12-2
1204. <a href="#">Transfer Switches</a> .....	12-2
1205. <a href="#">1-Phase/3-Phase, Full Service Backup</a> .....	12-4
1206. <a href="#">1-Phase/3-Phase, Partial Load Backup</a> .....	12-5

**CHAPTER 13 – CLEARANCES**

1300. <a href="#">Scope</a> .....	13-1
1301. <a href="#">Minimum Clearances for Services, 300 Volts and Below</a> .....	13-2
1302. <a href="#">Service Mast Installation - Roof Clearances, Clearance of Service Drop</a> .....	13-4
1303. <a href="#">Minimum Clearances for Services, 300 Volts and Below, Over Pools</a> .....	13-6
1304. <a href="#">Minimum Clearances for Services Over State and Federal Highways</a> .....	13-6
1305. <a href="#">Service Conductor Clearance From Signs</a> .....	13-6
1306. <a href="#">Clearance Envelope for Grain Bins</a> .....	13-7
1307. <a href="#">Special Horizontal Clearances for Overhead Cable Services</a> .....	13-8
1308. <a href="#">Pad-mount Transformer Locations</a> .....	13-10
1309. <a href="#">1PH, Pad-mount Transformer Protection &amp; Metering Equipment</a> .....	13-14
1310. <a href="#">3PH, Pad-mount Transformer Protection &amp; Metering Equipment</a> .....	13-15
1311. <a href="#">Barriers</a> .....	13-16
1312. <a href="#">Recreational Vehicles, Mobile Homes, Manufactured Homes &amp; Park Trailers</a> .....	13-17
1313. <a href="#">Solar Panel Clearance Requirement</a> .....	13-17

**CHAPTER 14 – GROUNDING AND INTERSYSTEM BONDING**

1400. <a href="#">Scope</a> .....	14-1
1401. <a href="#">General</a> .....	14-1
1402. <a href="#">Bonding Service Entrance and Metering Equipment</a> .....	14-6
1403. <a href="#">Bonding Conductor Sizing</a> .....	14-7

**CHAPTER 15 – ELECTRIC VEHICLES**

1500. <a href="#">Scope</a> .....	15-1
1501. <a href="#">Electric Vehicle (EV) Charging</a> .....	15-1
1502. <a href="#">Electric Vehicle (EV) Charging - Service Capacity</a> .....	15-1
1503. <a href="#">Level III DC Fast Charging (DCFC) (480V)</a> .....	15-3

**[Index](#)**

**[Supplement – Single-Phase and Three-Phase Handouts](#)**

**[2024 Summary of Changes](#)**

---

*This page is intentionally left blank*

Alliant Energy

# Chapter 1

Electric Service Rules

**RESERVED FOR NOTES:**



## CHAPTER 1

### ELECTRIC SERVICE RULES – GENERAL INFORMATION

---

#### 100. GENERAL

The use of the name Alliant Energy in this Electric Service Rules (ESR) e-manual refers to the electric utility operations for Interstate Power and Light (IP&L) and for Wisconsin Power & Light (WP&L).

#### 101. PURPOSE

- A. The purpose of this ESR e-manual is to supply essential information to those concerned with the planning and construction of electric service installations in Alliant Energy's service areas.
- B. Information in this ESR e-manual is intended to cover typical installations. Alliant Energy shall be consulted for installations not covered by this manual.
- C. Call Alliant Energy at 1-800-ALLIANT (800-255-4268) for all electric service installations and upgrades. A representative will assist in the planning and scheduling and be available to explain all applicable rates and rules.
- D. All information provided in this ESR e-manual is used in conjunction with Alliant Energy's tariffs on file with the Iowa Utilities Board and the Wisconsin Public Service Commission.

**This edition of the Electric Service Rules supersedes all previous editions.**

**Informational Note:** *The purpose for the existence of the Electric Service Rules e-manual is to convey Alliant Energy's requirements that are in addition to the National Electric Code (NEC). The reasons for being more restrictive are safety, power quality and standardization.*

#### 102. SCOPE

The scope of this ESR e-manual is to provide information to assist in the design and construction of electric service installations. Information is provided to address the responsibilities for ownership, installation and maintenance of equipment to accommodate installation of utility owned overhead and underground service laterals and the installation of customer termination and metering facilities.

#### 103. CODES AND RULES

Alliant Energy requires that all customer wiring installations meet the minimum requirements of the *National Electrical Code (NEC)*, *National Electrical Safety Code (NESC)*, *National Fuel and Gas Code (NFPA 54)*, *Liquefied Petroleum Gas Code (NFPA 58)*, *International Building Code (IBC)*, *International Fire Code (IFC)*, DOT Regulations and/or state and local codes when their requirements are more restrictive.

- A. **COMPLIANCE:** Alliant Energy reserves the right to refuse to extend service where a customer's installation does not comply with these provisions and requirements as stated. Alliant Energy shall inform the customer of the reason for service refusal.
- B. Alliant Energy may de-energize any service when that service is in an unsafe condition.
- C. Alliant Energy may give a disconnect notice for services in need of repair.



## ELECTRIC SERVICE RULES

## GENERAL INFORMATION

Issued Jan 2024

*Informational Note: Prior to reconnecting service, the service installation shall be approved by Electric Metering and Alliant Energy Engineering. The customer shall (at customer's expense) provide proof of inspection by a licensed electrician or a local licensed electrical inspector deeming the service safe. A wiring statement/affidavit shall be completed before service is energized. (e.g. Hot socket or damaged equipment)*

**104. WORD APPLICATION**

- A. **“Shall”** denotes a rule or mandatory requirement which must be followed.
- B. **“Should”** recommends a desirable practice for a specific condition.
- C. **“May”** indicates a possible option.
- D. **Definitions:** The local Authority Having Jurisdiction (AHJ) will make the final determination as to the building classification.
  - 1. **“Building”** is defined as a structure which stands alone, or which is separated from adjoining structures by fire walls. Check with local AHJ as to whether the building in question is a single building or classified as more than one building.
  - 2. **“Structure”** other than a building is defined as a substation, pole, pedestal, vault, pad-mounted switchgear, communication tower or other structure identified by Alliant Energy.
  - 3. **“Electrically Isolated Building”** is defined as a building where there are no continuous metallic paths to any other building or structure. These metallic paths include but are not limited to: electrical conduit and wiring (phase, neutral or grounds), communication systems (telephone, coaxial cable, data lines, etc.) and metallic piping (water, steam, hydraulic, augers, fencing, etc.). Separation to other buildings, structures and equipment must be sufficient to prevent lightning flashover.
  - 4. **“Row-house”** is defined as three or more contiguous living units, not more than three stories high. It is separated by firewalls having a minimum one-hour fire resistive rated construction which extends from the foundation to the underside of the roof deck with no doors or windows in the firewall.
  - 5. **“Zero Lot Line Building”** is defined as buildings separated by a common firewall as allowed by the local AHJ.

**105. CONTINUITY OF SERVICE**

- A. Alliant Energy's goal is to provide continuous electric service, restore service promptly and maintain its facilities with minimal inconvenience to customers. However, Alliant Energy does not guarantee continuous service, standard voltage or frequency at all times.
- B. Customers who are operating equipment that is sensitive or require a higher quality of service may find it necessary to install, at their own expense, power-conditioning equipment to protect, mitigate or otherwise provide the standard of service needed by their equipment.
- C. If a customer's electric meter has been inactive for 12 months in WP&L or 18 months in IP&L, the customer will be billed a monthly meter charge or Alliant Energy will remove the electric meter and our electric metering equipment. Prior to reconnecting service, the service installation shall be approved by Electric Metering and Alliant Energy Engineering. The customer shall (at customer's expense) provide proof of inspection by a licensed electrician or a local licensed electrical inspector deeming the service safe. A wiring statement/affidavit shall be completed before service is energized.

**106. POINT OF SERVICE**

The energy supplied by Alliant Energy changes ownership at the point of service. This is the location where the customer's wiring starts and Alliant Energy's ends. For overhead, the point of service is where Alliant Energy attaches its service drop to the building or structure. For underground, the point of service is at the primary metering point, self-contained meter, metering transformer cabinet or termination box.

**107. APPLICATION FOR SERVICE**

Applications for a new service and/or changes to an existing service shall be made in writing and made in advance of the required service date. This will permit Alliant Energy to plan and schedule work to provide service by the date required. Please call 1-800-ALLIANT (800-255-4268).

**A. Application forms:**

The proper application for service shall be submitted when applying for service.

**B. Service Location:**

1. The customer shall call Alliant Energy Engineering for assistance and approval when determining the service location on the building or where the structure supporting the service will be located.
2. The customer shall provide Alliant Energy with all load information and the proposed service entrance size and voltage requirements with the application.

**C. Charges:**

After a review of the site and facilities in the area, Alliant Energy shall notify the customer if additional charges are required to cover the cost for the service.

**D. Easements:**

1. The customer shall provide Alliant Energy a recorded copy of the Certified Survey Map or a Plat of the property where the service will be required.
2. The customer shall provide government approved forms indicating the location of any existing or proposed septic systems.
3. The customer shall provide easements for service and/or distribution facilities where required.

**E. Line Clearance:**

The customer shall be responsible for clearing any trees or brush preventing service installation of Alliant Energy facilities.

**F. Electrical Wiring Inspections:**

1. Customer wiring installations shall meet the minimum requirements set forth by the state regulatory commissions and the local Authority Having Jurisdiction (AHJ). Alliant Energy shall receive written approval from the AHJ.
2. For all commercial and new residential services, a Certificate of Electrical Inspection is required before Alliant Energy will energize the service.
3. Alliant Energy reserves the right to inspect for compliance with the ESR and ESE e-manual but assumes no responsibility for inspection of the customer's installation.

**ELECTRIC SERVICE RULES**

**GENERAL INFORMATION**

**Issued Jan 2024**

4. If Alliant Energy personnel is on site and notices electrical installation may be unsafe, Alliant Energy reserves the right to request an inspection prior to energizing the customer service.

For additional information, contact Alliant Energy Engineering at 1-800-ALLIANT (800-255-4268).

**108. SERVICE VOLTAGES AND MAXIMUM AMPERAGE (600 VOLT OR LESS)**

Standard (600 Volt or less) service voltages provided by Alliant Energy are listed below. (Not every voltage is available at every location).

For service voltages greater than 600 Volts see Chapter 10 - Primary Service.

MAXIMUM SERVICE ENTRANCE AMPERAGE			
TRANSFORMER	POLE-MOUNT	POLE-MOUNT	PAD-MOUNT
SERVICE	OH <sup>7</sup>	UG	UG
120/240V-1 Phase	600 <sup>2,6</sup>	400 <sup>6</sup>	600 <sup>2,6</sup>
120/208V-1 Phase	200 <sup>1</sup>	200 <sup>1</sup>	200 <sup>1</sup>
120/208V-3 Phase	1200 <sup>3,4</sup>	400	3000 <sup>3,5</sup>
277/480V-3 Phase	600 <sup>2</sup>	400	3000 <sup>3,5,8</sup>

**SUPERSCRIPTS:**

1. Available only from an existing 120/208V 4 wire system, max. 200-amp network meter.
2. 600-amp Continuous Duty service or 800-amp Intermittent Duty Services in non-agriculture areas are limited by loading on 167 kVA transformer.
3. Continuous Duty Service.  
Service entrance equipment listed as “Continuous Duty” may be operated at its full load for 3 hours or more. Those listed as “Intermittent Duty” may only be operated at 80% of its full load for long periods and 100% of full load for short periods, depending upon its design.
4. Limited by loading on 3-167 kVA transformers. May require multiple electric service masts.
5. Limited by loading on the largest available Pad-Mounted Transformer for the service voltage being utilized.
6. In areas near livestock (within ~ 1/2 mile), single phase services are limited to the maximum sizes below. Larger single-phase services may be allowed pending Agriculture Representative testing. Additional system upgrades may also allow for larger services. All exceptions shall be forwarded to Agriculture compliance team for review (Refer to ESR e-manual Chapter 8):
  - a. 15kV and below: 400 Amp secondary
  - b. 25kV system: 800 Amp secondary
7. In Wisconsin, new services are underground as a standard. New overhead services by Alliant Engineering approval only.
8. 4000-amp intermittent duty service by Alliant Engineering approval only.

**NOTES:**

1. All services are intermittent duty unless stated otherwise.
2. All services shall be wye grounded neutral.
3. The customer shall contact Alliant Energy Engineering concerning all planned installations with service voltages above 480 volts.

**109. NUMBER OF SERVICES**

Alliant Energy provides each parcel of land or property with one service (refer to Section 108 for service sizes). Additional services may be permitted with approval from Alliant Energy Engineering. Additional services must meet specific requirements as described in the following sections.

Reference: *NEC 230.2*.

*Additional services may be permitted with approval from Alliant Energy Engineering, if the following requirements have been met:*

**A. PRIMARY SERVICE**

1. When a property is served at a primary distribution or transmission voltage the single service to the parcel of land rule applies. A second service at a transformed secondary voltage is not allowed with the following exceptions as indicated in paragraph (2) of this section. If buildings or structures or both, on a parcel of land have service at both primary and secondary voltages; this may have been allowed in the past, Alliant Energy now requires service upgrades to meet present *NEC* and ESR e-manual requirements.

**2. Primary Service Exception**

A separate secondary voltage service may be provided for supplying fire pumps, emergency systems, or to the control buildings used for distributed generation facilities when the general service is at primary voltage. Fire pump or emergency services are treated as standby service/duplicate facilities according to Alliant Energy's extension rules.

**3. Backup Service**

A backup service is allowed as a separate service to the customer's property but may only be utilized when the primary service is not available. Primary and backup services may share common metering or be separate. The backup service shall have an open switch at the perimeter of the customer's property, separating this service feed from the main service feed to the customer's load. When the customer's main feed is interrupted, the open switch for the backup service will be closed by Alliant Energy to pick up the customer's load.

**4. Agriculture Primary Metered Services**

Primary metered services are not available for animal confinement facilities without prior approval from the agriculture compliance manager.



**B. UNDERGROUND SECONDARY NETWORK SERVICE**

*Alliant Energy shall comply with network standards for all underground network.*

Totalized metering may be used within the underground network system. The meter shall serve only one customer with facilities located contiguously within one city block having loads in excess of 500kW at 277/480V or an equivalent load. Alliant Energy will review each request to determine feasibility and cost of such metering schemes.

**C. SECONDARY SERVICE**

*Alliant Energy Engineering shall approve each exception for multiple services.*

Reference: *NEC 230.2E & NEC 250.58*

**Informational Note:** *The number of services is limited to increase safety for occupants and first responders, improve power quality and standardization. Alliant Energy does not bill separately for each individual transformer; therefore, the following distance requirements exist.*

**1. Distance Exceptions:****a) Buildings**

For buildings that cannot be served by only one service, Alliant Energy may provide a second service at any available secondary voltage. The new service shall be located 150 ft. from the existing 120/240 Volt service or 120/208 Volt 3-phase service. If either the existing or the new service is 277/480 volt, 3-phase, a minimum of 150 ft. separation shall be maintained.<sup>1</sup> Each of the above distances is measured in a straight line. The distance is measured between utility service terminations. All underground conductors supplied for each service shall have no common raceway or connection with any other service.

**Informational Note:** *The 150 ft. minimum spacing is from Wisconsin's State Electrical Code SPS 316.*

**2. Multiple Occupancy Buildings Exception (NEC 230.2B):**

A separate service may be provided for each multiple metered building. Multi-metered buildings may have a second service provided the distance separation requirements are met.

**3. Electrically Isolated Service Exception:**

Additional service(s) may be provided to separate buildings or structures, where there are no electrically conductive (i.e. wiring) paths to another service, (for example Electric vehicle chargers). Services provided by this exception are treated according to Alliant Energy's extension rules.

**4. EV Charging Station Exception:**

See Chapter 1502C

**5. Communication Facilities:**

Exception only applies to Iowa. See section 119

**6. Load Exceptions:****a) Single-Phase Service**

An existing single-phase customer whose 120/240 Volt load requirements exceed the ability of a 167 kVA transformer to serve the load shall convert to a three-phase service. The new service shall be a 120/208 or a 277/480 Volt, three-phase, four-wire service. This new service shall be sized to handle all existing and future loads of the combined services to facilitate prompt retirement of the 120/240 Volt single-phase service. If it is not feasible to retire the single-phase service when the three-phase service is energized, the customer may, with written permission from Alliant Energy Engineering, have up to six months to complete the transfer of all loads to the new service. At the end of the transition time, the single-phase service will be removed.

**b) Three-Phase Service**

It is preferred that customers upgrade to the maximum allowed underground service size before considering a second service. However, if the total demand of an existing service plus the estimated demand of a proposed expansion is greater than 430 kW at 120/208 Volts or 1 MW at 277/480 Volts, an additional service may be provided adjacent to the first service entrance. When multiple services are installed, they shall be of the same voltage. Must be 2000 Amps or greater.

**c) 120/240 Volt Delta Service**

When the demand of an existing three-phase 120/240 Volt Delta, four-wire customer exceeds the rated capacity of the customer's existing service entrance, the customer shall convert to a 120/208 or a 277/480 Volt three-phase, four-wire service. This new service shall be sized to handle all existing and future loads of the combined services to facilitate prompt retirement of the 120/240 Volt delta service. If it is not feasible to retire the delta service when the new service is energized, the customer may, with written permission from Alliant Energy, have up to six months to complete the transfer of all loads to the new service. At the end of the agreed upon transition time, the delta service will be removed.

**7. Special Conditions Exception:**

The preferred way to service loads listed in *NEC 230.2(A)* Special Conditions, is by connecting to the supply side of the service disconnect as allowed in *NEC 230.82*. The customer's special service will be served along with the main service from a single common drop or lateral.

As an alternative, a customer may also have a separate service drop or lateral and meter. These services are treated as standby services/duplicate facilities according to Alliant Energy's extension rules.

**a) Fire Pumps**

The utility transformer, utility service conductors and customer service equipment will be sized to serve full locked rotor current from the fire pump and accessory equipment, whether served from a dedicated service or from the load side of the metering transformer cabinet.

**Informational Note: Preferred installation would serve fire pump from the load side of the metering transformer cabinet. Saves customer on equipment costs, meter charges and allows testing during off peak times.**

**b) Emergency systems****c) Legally required standby systems****d) Optional standby systems****e) Parallel power production systems****f) Systems designed for connection to multiple sources of supply for the purpose of enhanced reliability.****8. Special Occupancies Exceptions:**

For row-house construction a separate drop or lateral may be provided for each two attached units. Buildings must comply with the unique building codes specifically intended for row-houses only. This does not apply for condominiums.

**9. Multiple Agriculture Services Only**

Livestock facilities and associated/connected premises, one service per Farmstead applies. All exceptions shall be forwarded to Agriculture compliance team for review (Refer to ESR e-manual Chapter 8) prior to starting construction.

**Informational Note: Farmstead is defined as a cluster of buildings and adjacent areas of a farm.**

10. Zero Lot Line Buildings as defined by the AHJ:

Where buildings extend to the property line, separated by a common firewall:

TWO FAMILY DWELLINGS WITH A COMMON WALL  
ALONG THE PROPERTY LINE (ZERO LOT LINE)

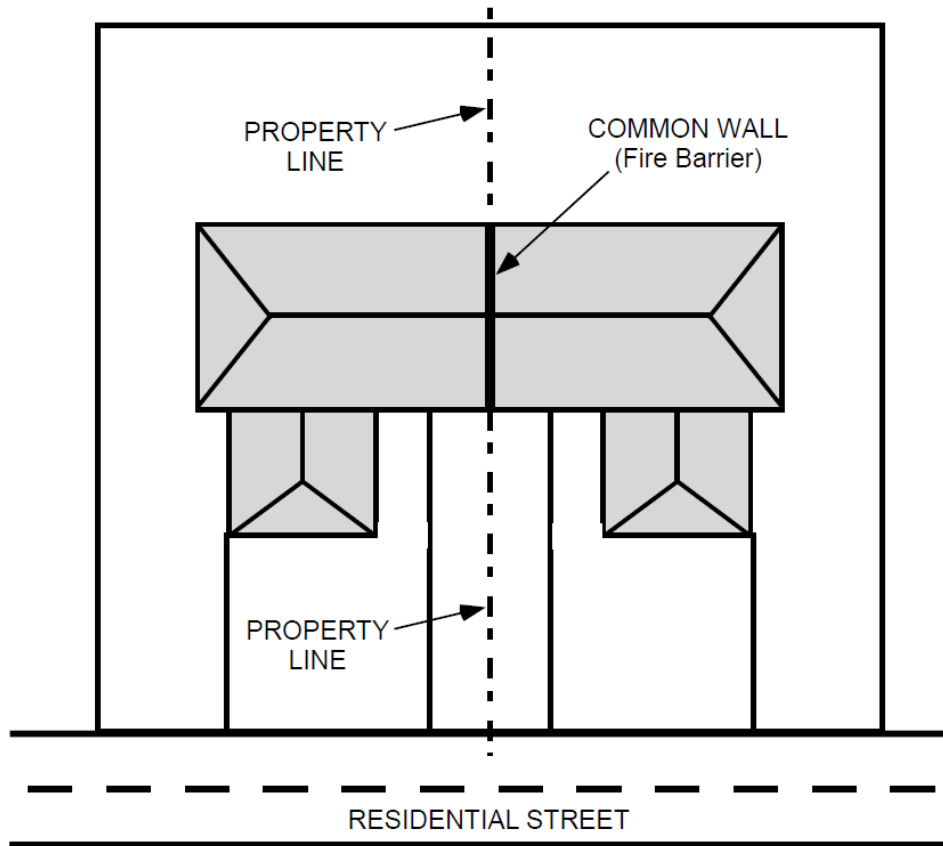

ESR 109.CVX

- a) If it is one building; then one service lateral with a multi-meter socket.
- b) If the buildings have a fire barrier(s)<sup>(1)</sup> as allowed by the local AHJ, then each building may have a separate service.
  - 1) Fire barriers shall extend from the top of the floor/ceiling assembly below to **“THE UNDERSIDE OF THE ROOF SLAB OR DECK ABOVE”**, (IBC 703 & 705/UL 263), no HVAC vents or other piping between the units through the firewall and no metallic paths may bond the two units together.
  - 2) Certified Survey Map (CSM) record indicates shared wall along property line.

**110. SHORT CIRCUIT DUTY REQUIREMENTS**

The customer’s service equipment and other devices shall be adequate to withstand and interrupt the maximum available short circuit current (Fault Current). Consult Alliant Energy for the available short circuit duty when requesting the location for service entrance facilities.

**Definitions:**

1. **Short Circuit Current Requirements (SCCR)** – The prospective symmetrical fault current at a nominal voltage to which an apparatus or system is able to be connected without sustaining damage exceeding defined acceptance criteria (*NEC 100*).
2. **Fault Current** – is an abnormal current in an electrical circuit due to a fault, usually a short circuit or abnormally low impedance path. There are three types of fault current; phase-to-neutral, phase-to-phase and phase-to-earth ground.
3. **Ampere Interrupting Capacity (AIC)** – This applies to circuit breakers and their ability to open and protect a circuit with a specific amount of current flowing in the circuit. Short Circuit Current Ratings are from 10,000 to 65,000 amps.
4. **ArcFlash Current** – The Available Fault Current for the Present System. The "Present System" values are for the existing system as of the date of the request. The values may change at any time without notice due to system changes. Sizing Entrance Equipment for interrupting capacity shall be done using the tables provided below.

*Informational Note: The Short Circuit Current Ratings listed are the greater of the phase to phase or the phase to neutral currents. Increasing a substation size and distribution conductor up to Alliant Energy’s largest standard size has been taken into account. The ratings listed are for the selection of equipment. For setting overcurrent protection for Selective Coordination, contact Alliant Energy Engineering for additional information.*

**A. SINGLE PHASE METERING:  
MINIMUM SHORT CIRCUIT CURRENT RATINGS**

120/240 VOLT, SINGLE-PHASE	
Service Ampacity	Minimum Short Circuit Current Ratings (AMPS)
60 amp	10,000
100 amp	10,000
150 amp	10,000
200 amp (service length > 50')	10,000
200 amp (service length < 50')	22,000
200 amp (120/208)	22,000
300 amp (Commercial)	22,000
320 amp (Residential)	22,000
400 amp (120/240V)	22,000
600 amp (120/240V)	35,000
800 amp (120/240V)	35,000

**NOTES:**

1. Due to fault current limitations, a single-phase service has a maximum transformer size of 50 kVA, or a 150 kVA three-phase overhead bank. If larger transformer is installed, these numbers

**ELECTRIC SERVICE RULES**

**GENERAL INFORMATION**

**Issued Jan 2024**

will change. Consult Alliant Energy Engineering for assistance with special applications, such as oversized transformers for high harmonic loads and other applications not covered by these tables.

2. Total service ampacity ratings of all present and future service entrance equipment connected to the same overhead service drop or underground service lateral.

**B. THREE PHASE METERING/BREAKER RATING:  
MINIMUM SHORT CIRCUIT CURRENT RATINGS**

120/208 VOLT THREE-PHASE	
Service Ampacity	Minimum Short Circuit Current Ratings (AMPS)
200	22,000
300	22,000
400	35,000
600	35,000
800	35,000
1200	65,000
1600	65,000
2000	65,000
2500	65,000
3000	65,000

277/480 VOLT THREE-PHASE	
Service Ampacity	Minimum Short Circuit Current Ratings (AMPS)
400	35,000
600	35,000
800	35,000
1200	35,000
1600	35,000
2000	35,000
2500	65,000
3000	65,000

**NOTES:**

1. Consult Alliant Energy Engineering for assistance with special applications, such as oversized transformers for high harmonic loads and other applications not covered by these tables.
2. Total service ampacity ratings of all present and future service entrance equipment connected to the same distribution transformer.
3. Minimum fault current equipment requirements do not apply to customer yard pole (CYP) pole top switches.

**C. Available Fault Current for ARCFIash Studies - Consult with Alliant Energy Engineering**

**111. INSPECTIONS AND MAINTENANCE**

In areas where electrical inspectors are provided, the inspector is the AHJ on all issues dealing with customer owned electrical wiring facilities.

**112. SERVICE CONNECTIONS**

Alliant Energy will make all service connections to its electric distribution system. Connection to or alteration of Alliant Energy's electric service facilities or other equipment is prohibited and subject to immediate disconnection. Alliant Energy shall only terminate service conductors in Alliant Energy approved equipment listed in Electric Service Equipment (ESE)e-manual.

**113. IDENTIFICATION OF CONDUCTORS**

- A. The neutral or grounded conductor of a service entrance (480 Volt and under) shall be identified by a white or gray color/tape or by three continuous white stripes on other than green insulation along its entire length.
- B. On 4-wire, delta connected secondary, where the midpoint of one phase winding is grounded to supply lighting and similar loads, the phase conductor having the higher voltage to ground shall be identified by an outer finish that is orange in color, by tagging or other effective means. Such identification shall be placed at each location where a connection is made if the grounded conductor is also present.

**114. CHANGES TO EXISTING SERVICE-ENTRANCE EQUIPMENT**

- A. When the customer is changing the ampacity of their service entrance equipment, they must meet the current State adopted version of the *NEC* and the ESR e-manual.
- B. When the customer modifies their service in any way that requires them to adhere to the current State adopted version of the *NEC*, they shall also adhere to the current ESR e-manual.
- C. Moving or relocating service equipment to new or different location shall constitute an upgrade. Exception by Variance Request only:
  - Customer is replacing or relocating damaged equipment, possibly to a better location, due to an accident, fire, storm or other natural disaster. Customer is not upsizing equipment, only replacing with equipment of the same size. Variance shall be submitted by Alliant Energy representative explaining the circumstances of this customer equipment change.
- D. 120/240V delta customers shall convert to a standard voltage with any upgrade. Exceptions by Variance Request only:
  - 1. Three phase primary does not exist at the customer location. Variance shall be submitted by Alliant Energy representative stating the location and age of nearest 3PH line along with cost of extending 3PH to the customer This Variance will also require a review from an Alliant Energy Agricultural Representative to verify there are no stray voltage concerns around the customer location.
  - 2. Customer owned equipment that is unable to be converted to a standard voltage. This requires an electrician review and estimate. Variance shall be submitted by Alliant Energy representative detailing the equipment that cannot be converted and the costs associated with converting or replacing this equipment. This Variance will also require a review from an Alliant Energy Agricultural Representative to verify there are no stray voltage concerns around the customer location.



**115. ALLIANT ENERGY EQUIPMENT ON CUSTOMER PREMISES**

- A. Customers shall grant Alliant Energy the right to install its equipment on the customer's premises to supply service. All such equipment shall remain Alliant Energy property and may be removed when service is no longer required.
- B. Alliant Energy shall have the right of access to equipment located on customer premises for inspection, maintenance, restoration and removal of service. The customer shall provide, without cost to Alliant Energy, the necessary easements and/or right-of-way for Alliant Energy personnel to install, maintain and access electric facilities that provide service to the customer. This will include permission to trim and/or remove trees and brush that may interfere with the installation and operation of Alliant Energy's facilities.
- C. Customers shall take care of Alliant Energy equipment located on their property. Customers will be responsible for all damages to or loss of Alliant Energy property located on their premise, unless damage is by causes beyond their control. The customer shall not grant authority to anyone who is not an employee of Alliant Energy to open or operate Alliant Energy equipment.
- D. Alliant Energy will attempt to give advance notice when accessing utility facilities on the customer's property but may not be able to do so during emergencies.

**116. CAPACITY**

- A. Service entrances shall have ample capacity per *NEC* Article 220 for any electrical load that may be expected to develop. All current carrying components of the metering installation shall have an ampacity rating equal to or greater than the required ampacity rating of the service entrance conductors.
- B. The customer shall give Alliant Energy notice of any load increases (permanent or temporary) which may require Alliant Energy to increase the capacity of its facilities. Customers who fail to notify Alliant Energy will be charged for the cost to replace damaged Alliant Energy equipment.
- C. For customer installations of two to six breakers or sets of fuses (service disconnects), on the load side of a termination box or metering transformer cabinet, the sum of the ampere ratings of the circuit breakers or fuses multiplied by 80% should not exceed the ampere rating of the termination or metering cabinet.
- D. The rating of the service disconnect is to be not less than the calculated load to be carried and not the actual load carried. (*NEC* 230.79)
- E. For 320 amp commercial services, self-contained metering is limited to 300 amps (example: maximum 2- 150A breakers, 1-200A and 1-100A breaker, or 1-300A breaker). For 320 amp residential services, self-contained metering is limited to 400 amps (example: maximum 2- 200A breakers).
- F. Adjustable breakers whose maximum rating, either individually or in combination, exceed the rating of the self-contained meter, are prohibited.
- G. Meter disconnect switches, nominally rated not in excess of 600 volts, shall have a short circuit rating equal to or greater than the available short circuit current. These devices shall also be grounded and bonded according to parts V & VII of Article 250. (*NEC* 230.82)

**117. SEQUENCE OF DISCONNECTING SERVICE AND METER**

The location of the service disconnect, unless specifically approved by Alliant Energy, shall be on the load side of the metering (**meter – switch – fuse**) sequence. “Hot Sequence”

**Exception #1:**

In multiple meter locations where the *NEC* requires a main disconnect, the sequence shall be:

**Main Service Disconnect – Meter – Switch – Fuse** “Cold Sequence”

**Exception #2:**

In the Cedar Rapids downtown, the sequence for the network system shall be:

**Switch – Meter – Switch – Fuse** “Cold Sequence”

**Exception #3:**

With special approval from Alliant Energy engineering and only on factory bussed equipment, a service disconnect may be installed ahead of the metering for 2 through 6-meter installations.

This sequence will then be:

**Switch – Fuse – Meter – Switch – Fuse** “Cold Sequence”

**118. CUSTOMER INSTALLATION**

- A. The customer installs, owns and maintains the service entrance equipment and provides a secure location for holding service wires and service entrance equipment to the building or structure. All service entrances shall include a service disconnecting means, over-current protection and Alliant Energy approved metering equipment located in the vicinity of where electric service is supplied to the building or structure.
- B. The *NEC* states where the service disconnects may be located. The Wisconsin State Electrical Code, Chapter SPS 316, states where the customer owned service entrance conductors and service disconnects may be located in Wisconsin. The Electric Service Rule e-manual states where utility owned service conductors shall be located, terminated and metered.
1. The *National Electrical Code* in Section 230.70(A) limits the location of the service disconnect to a readily accessible location either outside of the building or inside nearest the point of entrance of the service conductor’s location.
  2. The Wisconsin State Electrical Code in SPS 316.230(3)(b) states that conduits for service conductors located according to *NEC* 230.70(a) can extend no more than 8 feet into the building from the point they enter the inside of the building through the outside wall or concrete floor. (WP&L Only)

**Informational Note: The Wisconsin 8 ft. rule is in addition to NEC 230.70(A). In Wisconsin, service entrance disconnects, when located inside, must be near the point of entrance of the service conductor and must be within 8 ft. of where the conductors enter the building through the outside wall or concrete floor.**

3. This ESR e-manual limits the location and termination of utility owned service conductors to an installation on the outside of the customer’s building or structure.

**119. COMMUNICATION TOWER INSTALLATION**

- A. All communication towers are considered structures. Alliant Energy will provide either one underground service lateral or one overhead service drop to a tower site, regardless of the number of tower users.

**Iowa Exception:**

In the event that communication facilities are installed on an existing structure, (i.e. water tower, grain bin, etc.) that is served by a voltage other than that required by the communication user, a second service at the desired voltage may be permitted, with approval from Alliant Energy Engineering. The second service, at the different voltage, shall be located immediately adjacent to the first service entrance to facilitate the installation of the required bonding conductor between the two main disconnects.

- B. The tower owner will be responsible for providing metering and service entrance facilities to serve all tenants utilizing the tower facilities.
- C. Metering shall be made accessible to Alliant Energy personnel. Metering shall be installed in one of the following ways:
1. Outside of the customer's secured area.
  2. Inside a common fenced area or a separately fenced area and provide provisions for an Alliant Energy padlock. The metering shall be located 4' to 5' from the edge of the fence to facilitate reading the meters through the fence.
- D. When additional customers request service, Article 220 load calculations are required before the new service(s) will be energized.
- E. The normal sequence shall be **meter – switch – fuse**, if it is six meters or less. If in the future, more than six meters will be required, the customer shall install a service disconnect for a grouped meter assembly of modular design and factory bussed. The sequence would then be **switch – fuse – meter – switch – fuse**.
- F. The tower owner is required to install sufficient meter positions when the first tenant goes on the tower to accommodate all possible tenants. Label each position as Unit #1, Unit #2, etc. Do not use tenant names as tenants may change.
- G. Communication towers are considered a commercial account and shall have lever by-pass meter sockets. Each meter shall be placarded (see ESR e-manual 603) where multiple meters are installed.

Alliant Energy

# Chapter 2

Electric Service Rules

**RESERVED FOR NOTES:**



## CHAPTER 2

### ELECTRIC SERVICE RULES – TEMPORARY SERVICE

---

#### 200. GENERAL

- A. A service application shall be required for all temporary services. Alliant Energy will approve the location of all temporary service requests.
- B. Temporary services should not be active more than 12 months.
- C. Customers with temporary services shall notify Alliant Energy when the temporary service is no longer needed. Alliant Energy will then disconnect the temporary service from the customer's facilities.
- D. The customer shall pay all costs for Alliant Energy to install and remove the temporary service. The customer is also responsible for the energy usage costs.
- E. Temporary installations may not be reclassified as permanent unless such installations are constructed to conform to permanent requirements.
- F. Customer-owned temporary service entrances are not permitted on Alliant Energy-owned poles.
- G. Working space clearances, as defined by *NEC* 110.26, shall be required for temporary services.
- H. Large capacity (greater than 200 Amps), three-phase and primary temporary services - The customer shall submit specific proposals for approval from Alliant Energy's field engineering department at 1-800-ALLIANT (800-255-4268). Also see ESR e-manual, section 205.

**Informational Note: The Service Entrance of a Temporary Service must meet all the requirements of NEC.**

ELECTRIC SERVICE RULES

TEMPORARY SERVICE

Issued Jan 2024

201. OVERHEAD TEMPORARY SERVICE, SINGLE-PHASE, 3-WIRE, 120/240 or 120/208 VOLT, 200 AMP MAX (FOR CONSTRUCTION SITES)

Item No.	Description	■	●
		Furnished & Installed By Utility	Furnished & Installed By Customer
1	Meter	X	
2	Overhead service drop, see Note 1	X	
3	Service dead-end (Wisconsin: Furnished by Utility & Installed by Customer)	X (Wisconsin Only)	X (Iowa Only)
4	Pole min. class 7 or 4"x 4" treated post, min. 4' in ground		X
5	Service entrance wires with 36" leads		X
6	Rigid conduit or service entrance cable		X
7	Two braces of 2"x 4"x 16' or supporting guy		X
8	Approved Meter socket (See ESE e-manual E118 - E119)		X
9	Fused main disconnect switch or main		X
10	Ground in accordance with the NEC (See ESR e-manual Chapter 14)		X

**NOTES:**

1. Customer point of attachment shall be a minimum of 10' to a maximum of 100' horizontal separation from Alliant Energy facilities.
2. Attachment point shall be 6 - 12" below weatherhead.
3. Temporary services shall not be installed across public streets, roads, railroad tracks, or driveways.
4. Panel boards shall be service entrance rated. Panel boards with more than two single pole breaker positions require a main disconnect or breaker.
5. Panel boards, pedestals and installed breakers shall have a minimum fault current rating of 22kA if served from 100kVA transformer or larger.
6. Alliant Energy will approve location. Must be accessible by bucket truck.

201. OVERHEAD TEMPORARY SERVICE, SINGLE-PHASE, 3-WIRE, 120/240 or 120/208 VOLT, 200 AMP MAX (FOR CONSTRUCTION SITES) - CONTINUED

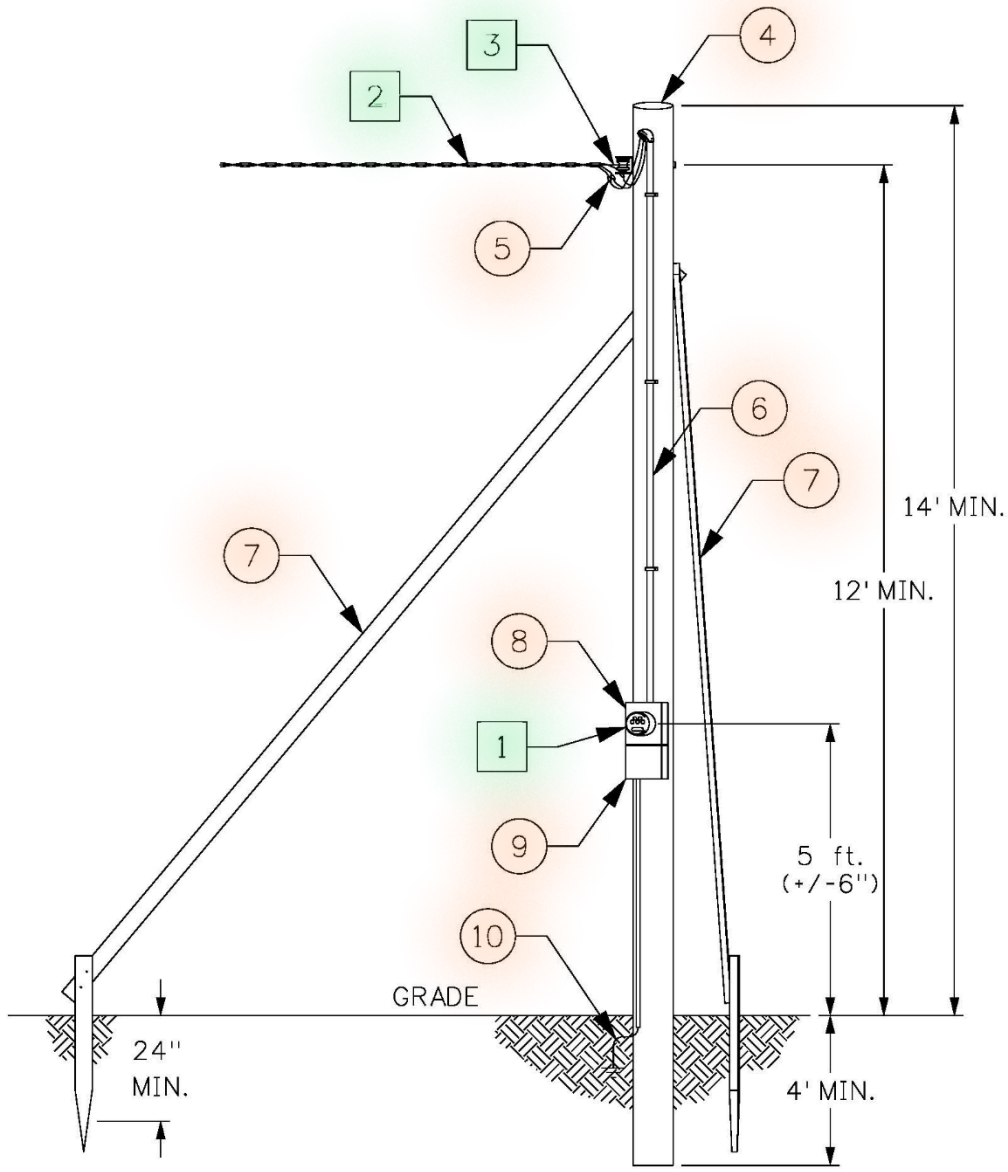

ESR201.dgn



**202. UNDERGROUND TEMPORARY/PERMANENT SERVICE - SINGLE-PHASE, 3-WIRE, 120/240 VOLT, 200 AMP MAX (FOR CONSTRUCTION SITES)  
PREFERRED CONSTRUCTION**

Item No.	Description	Furnished & Installed By Utility	Furnished & Installed By Customer
1	Meter	X	
2	Utility UG service conductors	X	
3	Approved pedestal (See ESE e-manual E113)		X
4	Customers main (Inside Panel)		X
5	Customer's feeder panel		X
6	Ground in accordance with the <i>NEC</i> (See ESR e-manual Chapter 14)		X

**NOTES:**

1. Approved Pedestal can be ordered with GFCI duplex receptacles for use by the contractor for construction.
2. Pedestal has separate exit channel for a breaker protected feeder to another building or structure.
3. Device will satisfy service requirements for permanent service when temporary use is no longer required. Temporary service costs and additional trips from Alliant Energy may be avoided.

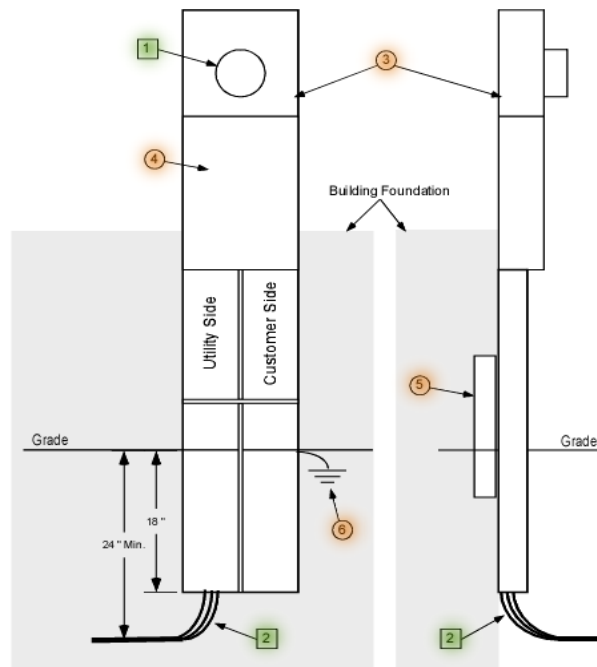

ESR 202\_CVX

**203. UNDERGROUND TEMPORARY SERVICE - SINGLE-PHASE, 3-WIRE, 120/240 or 120/208 VOLT, 200 AMP MAX (FOR CONSTRUCTION SITES)**

Item No.	Description	■	●
		Furnished & Installed By Utility	Furnished & Installed By Customer
1	Meter	X	
2	Service lateral LFMC* or LFNC**		X
3	4"x 4" treated wood post or approved manufactured pedestal		X
4	May use any approved meter socket. Meter socket shall be securely fastened.		X
5	Fused main disconnect switch or main circuit breaker with GFCI outlets (See ESE Section E118)		X
6	Ground in accordance with the NEC (See ESR e-manual Chapter 14)		X

\*LFMC – Liquid tight Flexible Metal Conduit – See NEC 350

\*\*LFNC – Liquid tight Flexible NON-Metal Conduit – See NEC 356

**NOTES:**

1. Temporary pedestal shall be placed within 3 feet of Alliant Energy’s supply source.
2. Panel boards and pedestals shall be service entrance rated. Panel boards with more than two single pole breaker positions require a main disconnect or breaker.
3. Panel boards, pedestals and installed breakers shall have a minimum fault current rating of 22kA if served from 100 kVA transformer or larger.

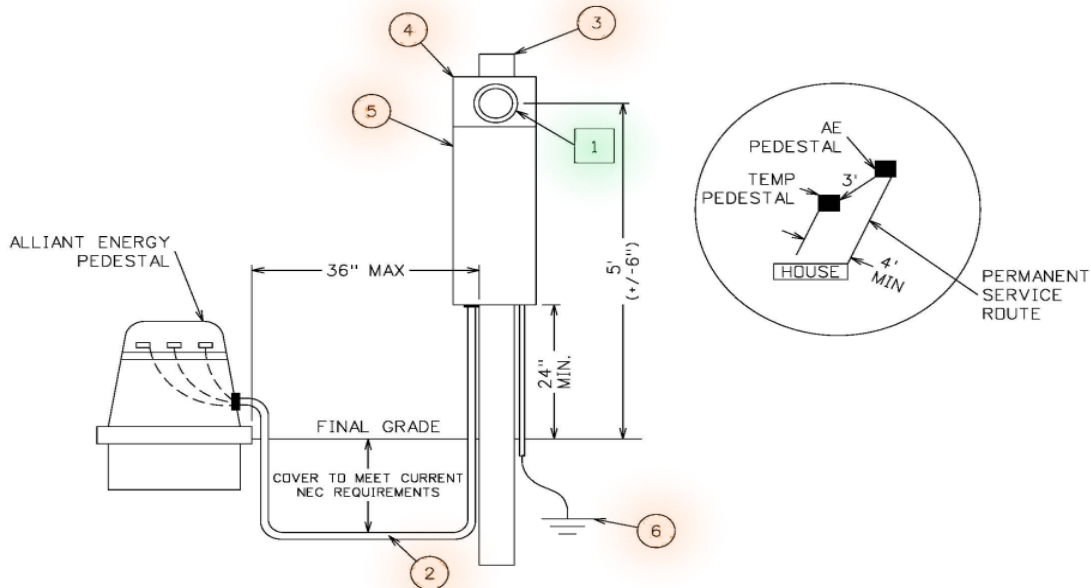

ESR203.dgn

ELECTRIC SERVICE RULES

TEMPORARY SERVICE

Issued Jan 2024

204. UNDERGROUND TEMPORARY SERVICE - SINGLE-PHASE, 3-WIRE 120/240 or 120/208 VOLT, 200 AMP MAX (FOR WINTER CONSTRUCTION SITES)

Item No.	Description	Furnished & Installed By Utility	Furnished & Installed By Customer
1	Meter	X	
2	Service lateral LFMC* or LFNC**		X
3	4"x 4" treated wood post or approved manufactured pedestal		X
4	May use any approved meter socket.		X
5	Fused disconnect switch or circuit breaker with Weatherproof GFCI Receptacles (See ESE Section E118)		X
6	Conduit straps over LFMC or LFNC		X
7	2"x 4" wood cross-member to support LFMC or LFNC		X
8	4"x 4" wood stake with 2"x 4" lagged for support		X
9	Ground in accordance with the NEC (See ESR e-manual Chapter 14)		X

NOTES:

1. Temporary pedestal shall be placed within 3 feet of Alliant Energy's supply source.
2. Panel boards and pedestals shall be service entrance rated. Panel boards with more than two single pole breaker positions require a main disconnect or breaker.
3. Panel boards, pedestals and installed breakers shall have a minimum fault current rating of 22kA if served from 100kVA transformer or larger.

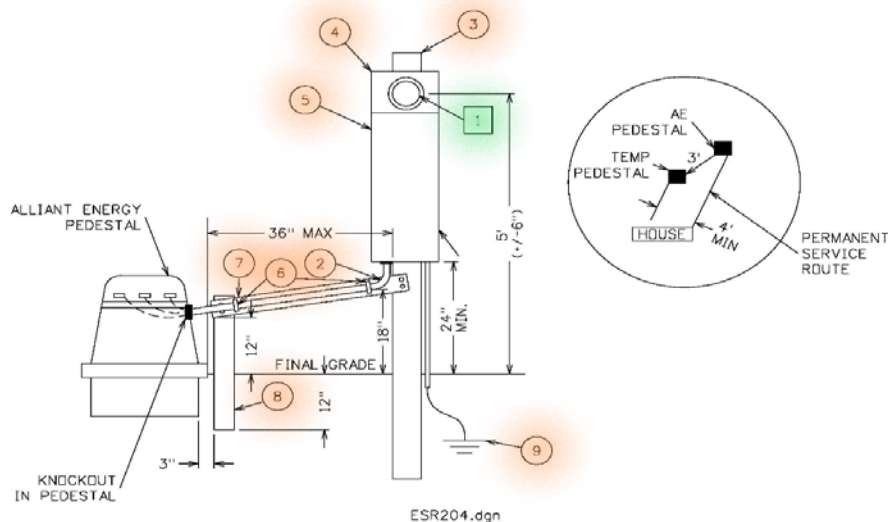

**205. LARGE TEMPORARY SERVICES, 1PH or 3PH**

301 - 400 AMP – 120/240 VOLTS – SINGLE-PHASE (FROM POLE XFMR)

301 - 600 AMP – 120/240 VOLTS – SINGLE-PHASE (FROM PAD XFMR)

400\* AMP – 120/208 VOLTS – THREE-PHASE (FROM POLE XFMR)

400 - 1200 AMP – 120/208 VOLTS – THREE-PHASE (FROM PAD XFMR)

400 AMP – 277/480 VOLTS – THREE-PHASE (FROM POLE XFMR)

400 - 1200 AMP – 277/480 VOLTS – THREE-PHASE (FROM PAD XFMR)

Item No.	Description	Furnished & Installed by Utility	Furnished & Installed by Customer
1	Meter	X	
2	Overhead service drop or Underground service lateral (in customer provided conduit)	X	
3	Metering cable (in customer provided conduit)	X	
4	Instrument transformers (inside cabinet)	X	
5	Approved meter socket (See ESE e-manual E105 )		X
6	1" rigid galvanized steel conduit		X
7	Metering transformer cabinet (See ESE e-manual E201- 204, E209 -E212 )		X
8	Service conduit(s) (overhead or underground) *		X
9	Field built structure - temporary or permanent (ESR e-manual 609)		X

\*Expansion joints are required

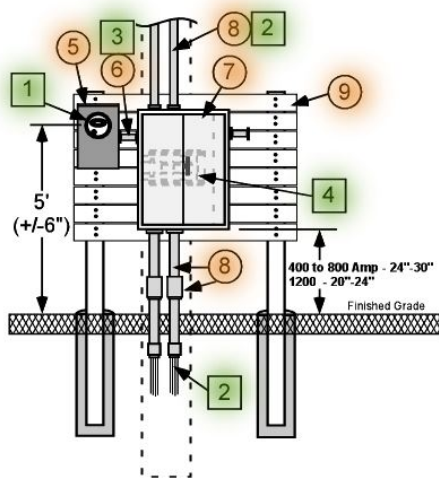

ESR 205.CVX

Large temporary services require an approved metering transformer cabinet. In all cases the metering transformer cabinet shall be attached to an approved field built or permanent structure.

Alliant Energy

# Chapter 3

Electric Service Rules

**RESERVED FOR NOTES:**

## CHAPTER 3

### ELECTRIC SERVICE RULES – OVERHEAD SECONDARY SERVICE

#### 300. SCOPE

This chapter covers the requirements and rules for overhead residential and commercial secondary services for Alliant Energy customers. Refer to ESR e-manual section 108. If in a rural area additional restriction may apply. Refer to ESR e-manual Chapter 8.

#### 301. ATTACHMENT OF SERVICE DROPS

- A. The customer’s structure shall support the service drop and meet required clearances for the service drop and drip loops above the ground, buildings, driveways, roads and other facilities.
- B. In Wisconsin, Alliant Energy will supply a standard service attachment device, if requested, and the customer will install the service attachment device. In Iowa, the customer shall provide and install the attachment device.
- C. For connection to Alliant Energy’s service drop wires, the customer’s service entrance conductors shall extend at least 36 inches beyond the weatherhead for a single service riser.
- D. Neutral conductors are to be identified according to the *National Electric Code (NEC)*.
- E. The maximum height Alliant Energy will attach a service drop to a building is 20 feet above the ground. If a greater attachment height is required, customer shall obtain prior approval from Alliant Energy Engineering.

#### 302. SERVICE RISER REQUIREMENTS

##### 2 to 6 Self-Contained Meters

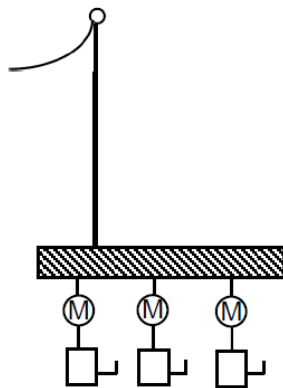

(2 to 6 Meters)  
(2 to 6 Service Disconnects)

ESR 302.cvx

#### NOTES:

1. Cable tray or raceway shall be NEMA 3R, lockable and sealable by Alliant Energy.
2. Refer to ESR e-manual Section 108 for maximum allowable entrance size for each service voltage.
3. One service with up to three masts going to a raceway or cabinet.

**303. SERVICE MAST CONSTRUCTION**

- A. Service masts for support through the roof shall be constructed of Rigid Galvanized Steel (RGS) conduit with an inside diameter of no less than two inches. Intermediate Metal Conduit (IMC) is not allowed as a service mast through the roof. See Table 302.
- B. The portion of the mast above the uppermost conduit support (roof line) shall be continuous in length without couplings.
- C. Some service masts over 48 inches may require guying. Contact Alliant Energy before constructing masts more than 48 inches above the roof line.
- D. Service masts shall not extend more than 6 feet above any sloped roof. This height is measured from the point where the conduit exits the roof to the top of the weatherhead.
- E. Only power service-drop conductors shall be permitted to be attached to a service mast - *NEC* 230.28.

**MAXIMUM HEIGHT OF WEATHERHEAD ABOVE SUPPORT  
ON AN UNGUYED SERVICE MAST  
Heavy loaded service drop tension may not exceed 500 LBS.**

Table 302

Type of Conduit Material	Conductor Size	SERVICE DROP LENGTH	2" Conduit	2 1/2" * Conduit	3" * Conduit
<b>Rigid Galvanized Steel (RGS) Conduit</b>	<b>#2 Aluminum Triplex</b>	30'	6'-0"	8'-0"	8'-0"
		40'	6'-0"	8'-0"	8'-0"
		50'	5'-10"	8'-0"	8'-0"
		60'	5'-1"	8'-0"	8'-0"
		70'	4'-7"	7'-6"	8'-0"
		80'	4'-1"	6'-8"	8'-0"
	<b>#1/0 Aluminum Triplex</b>	30'	6'-0"	8'-0"	8'-0"
		40'	6'-0"	8'-0"	8'-0"
		50'	5'-0"	8'-0"	8'-0"
		60'	4'-4"	7'-2"	8'-0"
		70'	3'-11"	6'-4"	8'-0"
		80'	3'-7"	5'-8"	8'-0"

\* Service masts cannot extend more than 6 ft. above any sloped roof regardless of the slope. They can however extend to more than 6 ft. above a flat roof where a ladder can be safely used.



304. SERVICE MAST INSTALLATION

FLAT OR LOW-ROOFED BUILDINGS

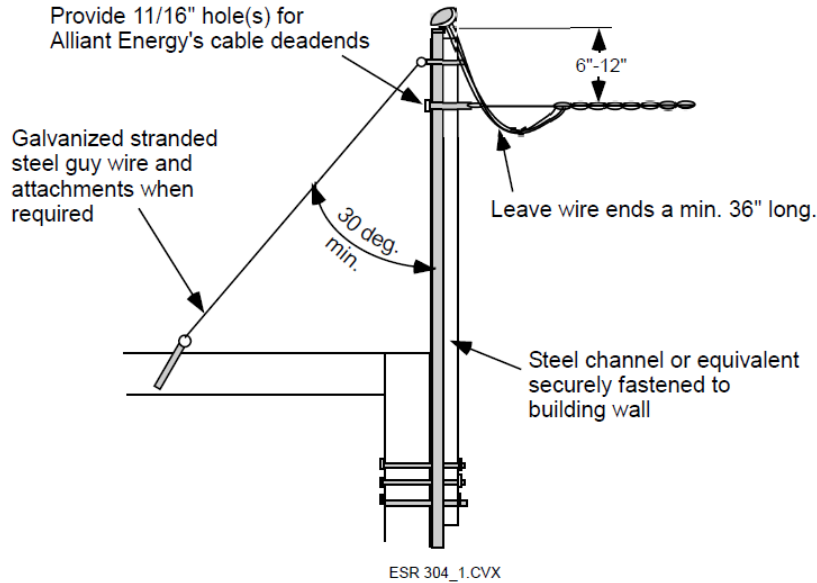

METAL BUILDINGS, BRICK OR MASONRY WALL

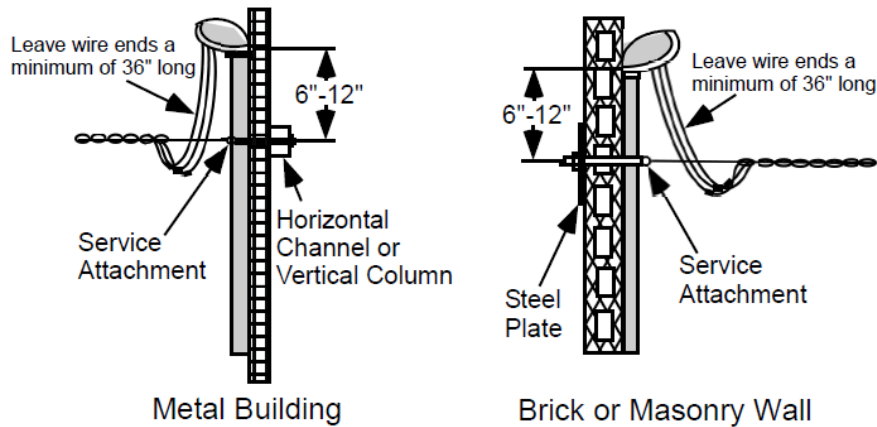

NOTES:

1. The customer shall consult Alliant Energy before any above installation is planned or started.
2. The customer furnishes, installs and maintains the installation except for Alliant Energy's service drop, connectors and cable dead-end.
3. The customer shall consult with Alliant Energy for service drop tensions and provide an attachment with adequate strength. The installation shall meet required clearances for the Alliant Energy's overhead service drop.

305. WALL OR THROUGH-THE-ROOF INSTALLATION – PREFERRED CONSTRUCTION

Item No.	Description	Furnished & Installed by Utility	Furnished & Installed by Customer
1	Meter	X	
2	Overhead service cable	X	
3	Service dead-end clamp or grip and connectors	X	
4	Service attachment point	Furnished by utility upon request installed by customer	
5	Rain-tight weatherhead		X
6	Service entrance wires with 36" leads		X
7a	Rigid conduit (wall application)		X
7b	Rigid galvanized steel (RGS) conduit (Through the roof)		X
8	Conduit guy – 1/4" Min. Galv. Steel (if required)		X
9	Bracing between studs for guying hardware		X
10	Conduit or cable supports (as required)		X
11	Approved meter socket (See ESE e-manual)		X
12	Customer's service entrance panel		X
13	Ground in accordance with the NEC (See ESR e-manual Chapter 14)		X
14	Disconnect for 480 volt services only		X

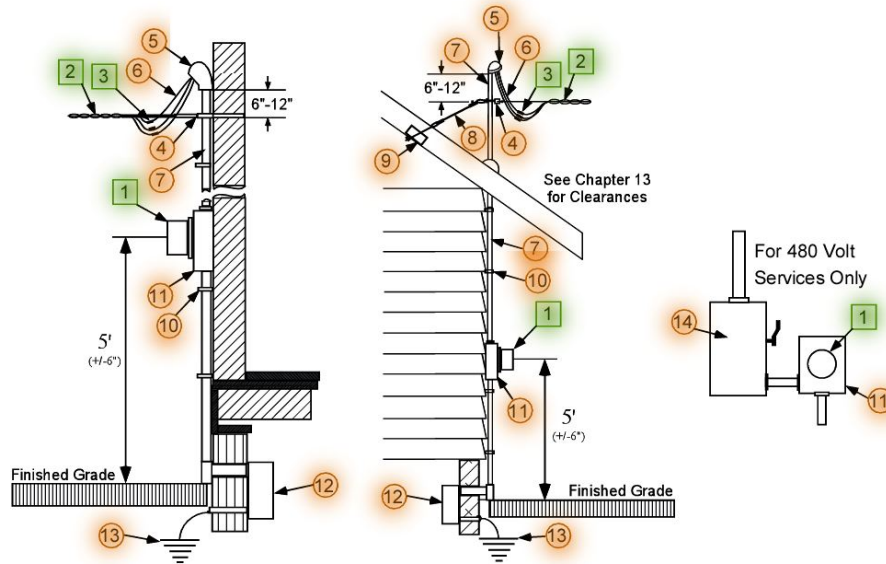

Figure 7a (Wall application)

Figure 7b (Through the roof application)

ESR 305.CVX

ELECTRIC SERVICE RULES

OH SECONDARY SERVICE

Issued Jan 2024

306. POLE MOUNTED SERVICE ENTRANCE - 240 VOLTS MAX - OPTIONAL CONSTRUCTION

Item No.	Description	Furnished & Installed by Utility	Furnished & Installed by Customer
1	Meter	X	
2	Overhead service cable	X	
3	Service dead-end clamp or grip	X	
4	Service attachment through bolt and connectors	Furnished by utility upon request installed by customer	
5	Pole, treated, class 6 minimum, 5" dia. at top		X
6	Rain-tight weatherhead		X
7	Service entrance wires with 36" leads		X
8	Rigid conduit or service entrance cable		X
9	Guy, galvanized stranded steel, 1/4" minimum		X
10	Guy Guard		X
11	Anchor		X
12	Approved meter socket (See ESE e-manual)		X
13	Service entrance equipment		X
14	Ground in accordance with the NEC (See ESR e-manual Chapter 14)		X

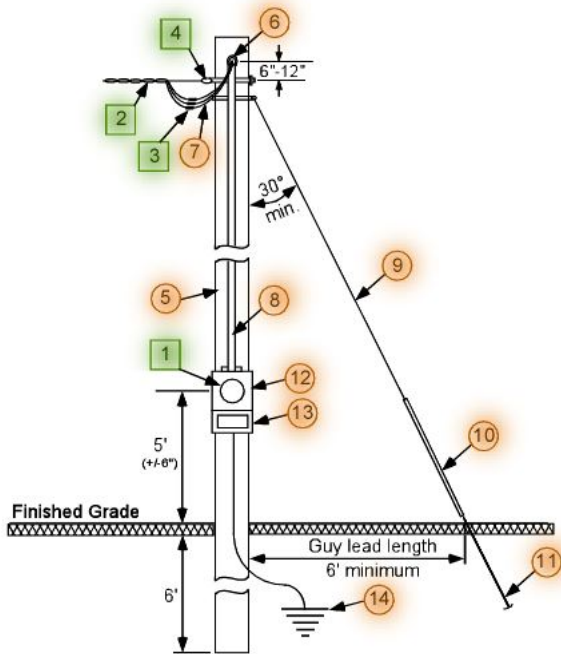

ESR 306.CVX

NOTES:

1. The customer shall consult Alliant Energy before such an installation is planned or started.
2. Preferred method of construction would be to have this type of service on a building.
3. Customer pole shall maintain minimum 12' horizontal separation from Alliant Energy facilities.

Alliant Energy

# Chapter 4

Electric Service Rules

**RESERVED FOR NOTES:**



## ELECTRIC SERVICE RULES

UG SECONDARY SERVICE

Issued Jan 2024

# CHAPTER 4

## ELECTRIC SERVICE RULES – UNDERGROUND SECONDARY SERVICE

---

### 400. SCOPE

This chapter covers the requirements and rules for underground residential and commercial secondary services for Alliant Energy customers. Refer to ESR e-manual section 108. If in a rural area additional restriction may apply. Refer to ESR e-manual Chapter 8.

### 401. GENERAL INFORMATION

- A. The underground service lateral is defined as Alliant Energy's underground service conductors from the last pole, pedestal, transformer, or other Alliant Energy structure, connecting to the customer's metering point, or termination equipment. Alliant Energy will install, own, and maintain the underground service laterals in accordance with applicable tariffs and extension rules. Alliant Energy shall not install underground service laterals, in locations Alliant Energy deems not suitable for underground cables and equipment.
- B. Alliant Energy shall not terminate service lateral conductors inside the customer's building. The termination point shall be outside the customer's building in free-standing or wall-mounted equipment, (self-contained meter, metering transformer cabinet, or a termination box). Alliant Energy shall not terminate on a customer's circuit breaker or disconnect switch.
- C. Before installing service entrance equipment, the customer shall apply to Alliant Energy for underground service and obtain approval for the service location. The customer shall install, own, and maintain all service entrance facilities other than the service lateral, meters, instrument transformers and instrument transformer wiring.
- D. The proposed cable route shall be clear of all obstructions and within 6 inches of final grade before Alliant Energy will install service lateral. A 10 feet wide cable route clear of trees and other obstructions shall be provided by the customer.
- E. Grade changes of more than 6 inches over Alliant Energy's underground cables are not allowed.
- F. Alliant Energy's cables shall not be located under buildings, decks, pools, or structures. Contact Alliant Energy of plans for future buildings, pools, decks, patios, etc.

### 402. SIZING UNDERGROUND FACILITIES

- A. **Conduit** - Number of conduits sized to customer's main disconnect. See Section 407.
- B. **Transformer Pad** – Consult Alliant Energy Engineering Department. Sized to customer's main disconnect. See Section 408-412: Three-Phase Transformer Pad Options.
- C. **Underground Conductors** - Sized to customer's load, voltage drop and flicker requirements.
- D. **Transformer** - Sized to customer's load.
- E. **Metering Transformer or Termination Cabinets** - Sized to customer's main disconnect.

**403. LOCATION OF ALLIANT ENERGY SECONDARY VOLTAGE CABLES****G. Buildings and Pools**

Alliant Energy's cables shall not be located under buildings, decks, pools, or structures. Contact Alliant Energy of plans for future buildings, pools, decks, patios, etc.

**A. Sidewalks, Hard Surfaced Parking Lots, Driveways, Patios, and Decks**

1. With approval from Alliant Energy, buried cables may be installed in conduit through these areas, if no other acceptable route exists. \*

\*Exception: Cable runs crossing under sidewalks at 90° may not be required to be installed in conduit, unless there are other circumstances that would require conduit.

2. With approval from Alliant Energy, a hard surface may be installed over the existing direct buried cable, provided a conduit with capped ends and tracer/pull wire(s), is/are installed 18-24 inches away and parallel to the existing cable, at a 24–36-inch depth.
3. Conduit, if required, is to be installed by the customer, or at the customer's expense. Services under concrete add conduit to 3 feet beyond edge of concrete.

**C. COMPLIANCE**

Whenever a direct buried cable installation is found to be out of compliance with any of the stated requirements, or in violation of local, state, or national codes, the customer's equipment and/or Alliant Energy facilities shall be modified at the customer's expense to bring the installation into compliance.

**404. UNDERGROUND SERVICE INSTALLATIONS****A. Services to Meter Sockets or Pedestals**

Alliant Energy shall install trench and cable for all underground services to self-contained individual meter sockets/pedestals, or a combination of no more than two grouped sockets serving a building. When a service conductor is installed in conduit(s), such as referred to in drawing 404A and 404B, an expansion joint is required online and load side.

\*Expansion joints shall be above final grade. Where conduit runs are used for services, the customer shall install a pull string in the conduit at the time of the conduit installation.

(Also see drawing 404A and 404B)

**B. Services to a Metering Transformer Cabinet, Termination Cabinet or Multi-Metering (with more than two meters)**

The customer shall install trench and service conduit for all services terminated in a group meter assembly or meter-pack of more than two meters, a metering transformer cabinet, or a termination cabinet. See 407 for number and size of conduit(s). An expansion joint for both the line and load side shall be required for all wall-mount services in this category. \*Expansion joints shall be above final grade. For all services with conduit runs, the customer shall install a pull string in the conduit at the time of the conduit installation. Alliant Energy shall provide service conductor cables and make all connections. Check with Alliant Energy for conduit size and number required. (Also see drawing 404B)

**ELECTRIC SERVICE RULES**

**UG SECONDARY SERVICE**

Issued Jan 2024

A building or structure installed on a state approved monolithic slab foundation shall comply with the ESR e-manual 404B drawing. Expansion joint(s) \*Expansion joints shall be above final grade and appropriately sized rigid conduit(s) are required at the service point and shall be installed by the customer or their contractor. In addition, the conduit(s) shall extend at least two feet away from the building or structure and shall be installed at the depth required by NEC/NESC. Digging around monolithic slab foundations shall be done by the customer or their contractor.

- C. The customer’s service installation shall be in compliance with all requirements of the *National Electrical Code (NEC)* and those of Alliant Energy.

**404A.**

**SELF-CONTAINED METER SOCKET, DIRECT BURIED CONDUCTORS**

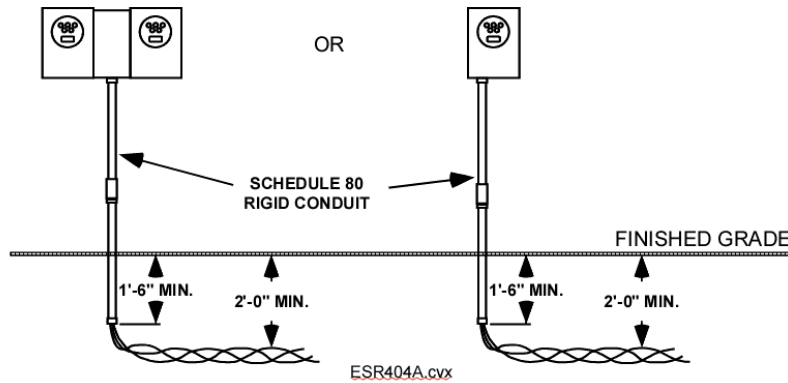

**404B.**

**METER SOCKET, METERING TRANSFORMER CABINET OR TERMINATION CABINET, CONDUCTOR IN CONDUIT**

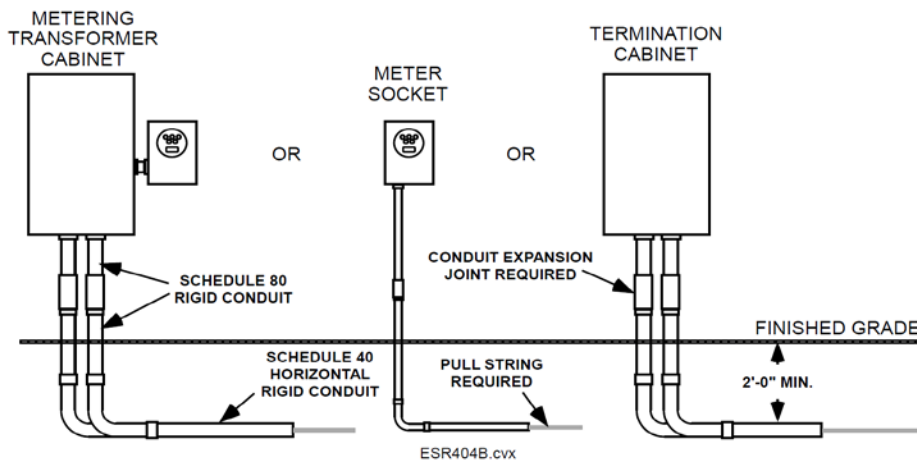

Note: For metering transformer cabinet or termination cabinet installations 1600A and larger pad-mount equipment is required.



**405. OUTDOOR METER SOCKET**

- 100 - 320AMP 1-PHASE 120/240 VOLT – RESIDENTIAL
- 100 - 300AMP 1-PHASE 120/240 VOLT – COMMERCIAL
- 100 - 300AMP 3-PHASE 120/208 VOLT
- 100 - 200AMP 1-PHASE 120/208 VOLT – COMMERCIAL



Item No.	Description	Furnished & Installed by Utility	Furnished & Installed by Customer
1	Meter	X	
2	Underground service cable	X	
3	Approved meter socket (See ESE e-manual E101 - E103, E106, A, B)		X
4	Rigid conduit		X
5	Insulating bushing		X
6	Conduit straps (In accordance with NEC)		X
7	Conduit expansion joint		X
8	Bell end		X
9	Concrete sleeve		X
10	Customer service entrance panel		X
11	Ground in accordance with the NEC (See ESR e-manual Chapter 14)		X

**NOTES:**

1. A concrete sleeve is only required where conduit passes through concrete.
2. Ground rods and grounding electrode conductor shall be installed to the left or right of the meter socket, not in front of the meter socket.
3. All individual underground residential and commercial meter sockets shall have a minimum rating of 100 amps. All commercial meter sockets shall be equipped with a lever bypass.

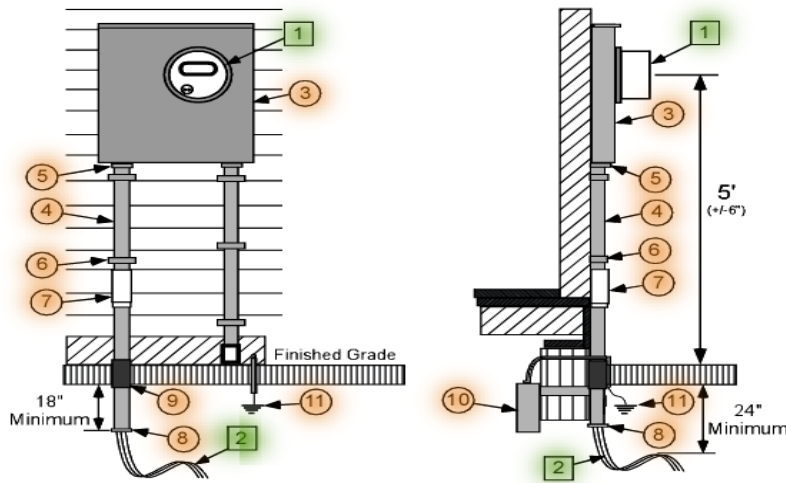

ESR 405.cvx

**ELECTRIC SERVICE RULES**

**UG SECONDARY SERVICE**

Issued Jan 2024

**406. OUTDOOR METER PEDESTAL SERVICE - WALL OR FREE STANDING SINGLE OR DUPLEX - WITH OR WITHOUT MAIN**

100 - 320AMP 1-PHASE 120/240 VOLT – RESIDENTIAL

100 - 300AMP 1-PHASE 120/240 VOLT – COMMERCIAL

100 - 300AMP 3-PHASE 120/208 VOLT

Item No.	Description	Furnished & Installed by Utility	Furnished & Installed by Customer
1	Meter	X	
2	Underground service cable	X	
3	Approved meter pedestal (See ESE e-manual E112 - E115)		X
4	Concrete sleeve		X
5	Ground in accordance with the <i>NEC</i> (See ESR e-manual Chapter 14 & Note 1)		X
6	Factory stabilization footing (See Note 3, free standing only)		X
7	Service Entrance Equipment - Main (See Note 2)		X
8	Rigid conduit - Customer load conductor (See Notes 4 & 5)		X

**NOTES:**

1. All the ground rods shall be installed on the same side of the meter pedestal. Ground rods shall not be placed within the pedestal.
2. The grounding electrode conductor may only terminate in pedestal with a main disconnect(s).
3. The pedestal shall be securely fastened to the building wall or foundation. A free-standing meter pedestal with a stabilization footing may be used where no substantial buildings are available.
4. A 3' square area shall be provided around pedestal to facilitate access to cable for repair or replacement. Conduit is required under concrete and shall extend 3' beyond edge.
5. Customer's load conductors shall not exit the bottom of the pedestal unless divided for metered and un-metered conductors. Customer load conductor may exit through factory knockouts of the pedestal.
6. Meter pedestal shall be at least 12' from the nearest pole or other Alliant Energy facility.

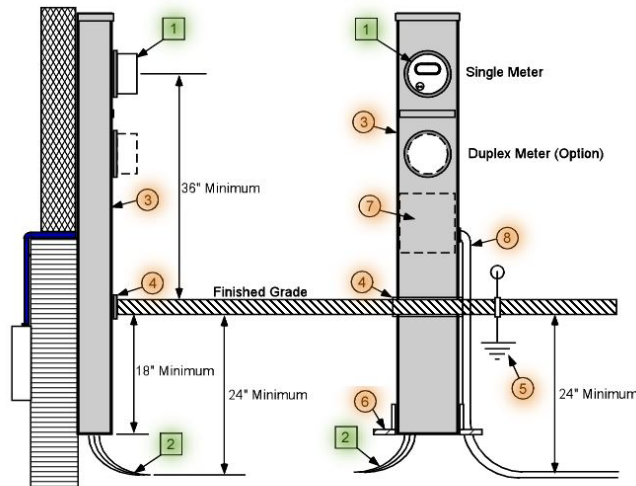

ESR 406.cvx

**407. RIGID CONDUIT**

- A. Rigid conduit includes Rigid Galvanized Steel (RGS), rigid aluminum, galvanized Intermediate Metal Conduit (IMC), or rigid nonmetallic conduit schedule 80 PVC electrically rated and schedule 80 equivalent polyethylene. The rigid nonmetallic conduit shall conform to specifications in Article 342, 344 and 352 of the *NEC*. Refer to individual sections for specific installations. Galvanized steel conduit may be either rigid steel or galvanized IMC. It shall not be Electric Metallic Tubing (EMT).
- B. Schedule 40 electrically rated PVC is allowed for horizontal runs 18 inches below final grade and into pad mounted transformers and pad mounted cabinets.
- C. The tables shown below are to be used by Alliant Energy personnel only, as a general guide to determine the conduit sizes and number for the services listed. The sizes & numbers of these facilities may have to be modified to take into account the length of the lateral, the customer loads and any voltage drop considerations that may apply. Alliant Energy will calculate voltage drop to make the final determinations.

**UNDERGROUND SINGLE-PHASE**

Main Service Disconnect Amperes	Minimum Number of Conduits	Conduit Size	Minimum Bend Radius Galvanized Steel	Minimum Bend Radius Rigid Non-Metallic
100	1	2"	9½"	18"
150	1	2"	9½"	18"
200	1	2" *	9½"	18"
300	1	3"	13"	24"
320 (residential)	1	3"	13"	24"
400	2	4"	16"	30"
600	2	4"	16"	30"
800	3	4"	16"	30"

\* A 2-1/2 inch conduit may be required if larger conductors are required

**Check with Alliant Energy engineering before installing service conduit**

**NOTES:**

1. All PVC service conduit elbows shall be performed.
2. For longer conduit runs containing three or more bends, the customer shall consult with Alliant Energy for the conduit size and for the radius bend to use.
3. When a service conductor is installed in conduit(s), such as referred to in drawing 404A and 404B, an expansion joint is required online and load side. \*Expansion joints shall be above final grade. Where conduit runs are used for services, the customer shall install a pull string in the conduit at the time of the conduit installation. (Also see drawing 404A and 404B). All Underground conduit runs need to be a minimum 18 inches.
4. Commercial services may be restricted to 25 Feet Max check with Alliant Energy engineering.

**ELECTRIC SERVICE RULES**

**UG SECONDARY SERVICE**

**Issued Jan 2024**

**UNDERGROUND THREE-PHASE (25 Feet Max)**

Main Service Disconnect Amperes	Minimum Number of Conduits	Conduit Size	Minimum Bend Radius Galvanized Steel	Minimum Bend Radius Rigid Non-Metallic
100	1	3"	13"	24"
200	1	3"	13"	24"
300	1	4"	13"	24"
400	2	4"	16"	30"
600	2	4"	16"	30"
800	3	4"	16"	30"
1200	5	4"	16"	30"
1600*	4	5"	24"	36"
2000*	5	5"	24"	36"
2500*	7	5"	24"	36"
3000*	8	5"	24"	36"

**Check with Alliant Energy engineering before installing service conduit**

**\* 1600-3000 Amp Termination and Metering Cabinets are pad mounted only.**

**NOTES:**

1. All PVC service conduit elbows shall be performed.
2. For longer conduit runs containing three or more bends, the customer shall consult with Alliant Energy for the conduit size and for the radius bend to use.

**SECTIONS 408 – 413: TRANSFORMER PAD OPTIONS**

The customer/contractor shall install, own and maintain a concrete pad or three-phase box pad whenever the underground service requires a three-phase transformer pad.

**408: Transformer Concrete Pad**

Metering transformer cabinet is wall-mounted or pad-mounted on a separate isolated pad.

**409: Concrete Foundation Walls for Transformer Pad**

Where unstable soil conditions exist to avoid tilting of pad, or where a large number of secondary cables are required to provide a cable training area.

**410: Back-to-Back Joint Transformer & Metering Cabinet Concrete Pad**

When metering transformer cabinet is pad-mounted and it is desired to pour a single pad for the metering transformer cabinet and transformer, this design requires the use of conduit between the transformer and metering transformer cabinet.

**411: Concrete Pad Specifications & Layout for Customer Owned Pad for Metering/TC**

Recommended Standalone Pad for Customer owned Metering/Termination. The design requires the use of conduit between the transformer and customer pad. Pad located to the front or rear of transformer is recommended.

**412: Three-Phase Fiberglass Transformer Box Pad**

Non-preferred Option: Metering transformer cabinet is wall-mounted or pad-mounted on a separate isolated pad.

**413: Single-Phase Fiberglass Transformer Box Pad**

Non-preferred Option: Metering transformer cabinet is wall-mounted or pad-mounted on a separate isolated pad.

**ELECTRIC SERVICE RULES**

**UG SECONDARY SERVICE**

Issued Jan 2024

**408A. CONCRETE PAD SPECIFICATIONS AND LAYOUT FOR THREE-PHASE, PAD-MOUNT TRANSFORMERS**

1. The customer/contractor shall contact Alliant Energy for sizes and number of primary and secondary conduits.
2. A maximum of 8 secondary conduits are allowed.
3. Pad shall rest on firm, well-compacted soil, free of organic or other undesirable materials.
4. Concrete mix shall have a minimum strength of 4000 lb./sq. in. after 28 days.
5. The top of the pad shall be level and all edges and corners rounded off.
6. The pad shall be reinforced with #4 wire, 4" x 4" welded mesh or equivalent materials with additional 3/8-inch reinforcing rods around the cable opening. The mesh shall not be less than 1 inch from the edges and opening and 3" below the surface.
7. If the #4 wire, 4"x 4" mesh is not available, two layers of #10 wire, 6"x 6" mesh, staggered by 2 inches horizontally, may be substituted for the #4 wire.
8. Macro-Synthetic Fiber may be used in lieu of wire mesh. The fiber shall be installed per manufacturer specifications for minimum shrinkage and temperature reinforcement for slab on grade applications.

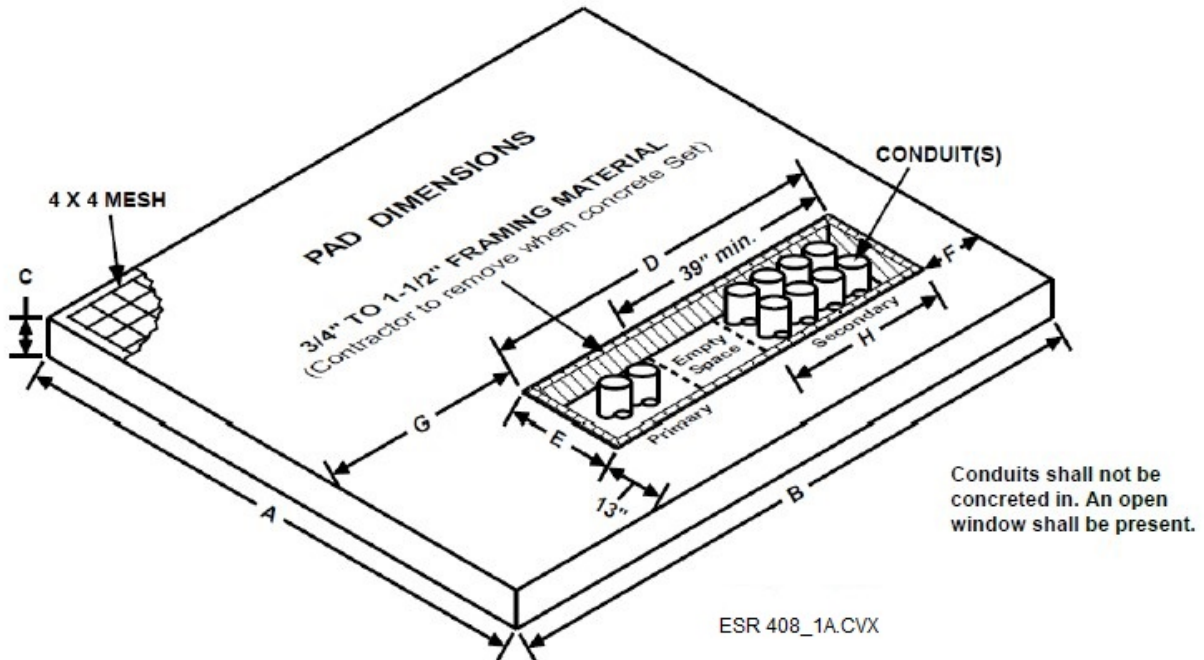

		SERVICE SIZE									
	XFMR	208Y/120	480Y/277	A	B	C	D	E	F	G	H
PAD	KVA	AMPS		INCHES							
I	75-500	100-1200	100-600	84	96	6	55	17	10	31	22
II	750-2500	1600-3000	800-3000	105	108	8	60	17	14	34	27

**408B. CONCRETE PAD SPECIFICATIONS AND LAYOUT FOR SINGLE-PHASE, PAD-MOUNT TRANSFORMERS OPTIONAL**

1. The customer/contractor shall contact Alliant Energy for sizes and number of primary and secondary conduits.
2. A maximum of 3 secondary conduits are allowed.
3. Pad shall rest on firm, well-compacted soil, free of organic or other undesirable materials.
4. Concrete mix shall have a minimum strength of 4000 lb./sq. in. after 28 days.
5. The top of the pad shall be level and all edges and corners rounded off.
6. The pad shall be reinforced with #4 wire, 4" x 4" welded mesh or equivalent materials with additional 3/8-inch reinforcing rods around the cable opening. The mesh shall not be less than 1 inch from the edges and opening and 3" below the surface.
7. If the #4 wire, 4" x 4" mesh is not available, two layers of #10 wire, 6" x 6" mesh, staggered by 2 inches horizontally, may be substituted for the #4 wire.
8. Macro-Synthetic Fiber may be used in lieu of wire mesh. The fiber shall be installed per manufacturer specifications for minimum shrinkage and temperature reinforcement for slab on grade applications.

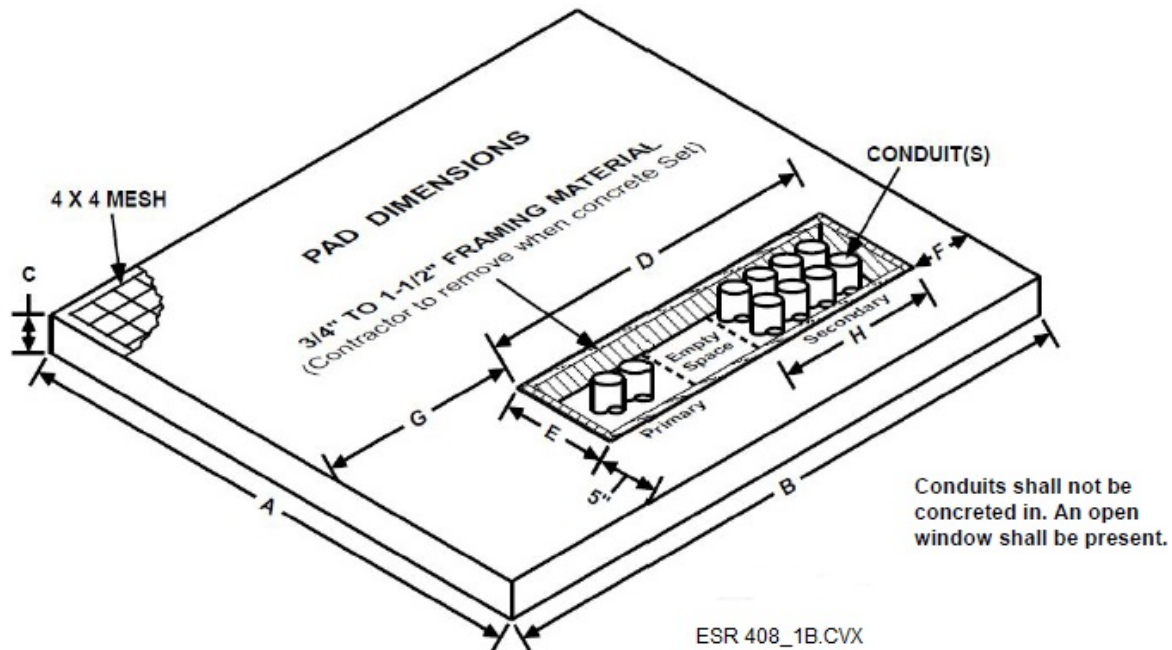

SINGLE PHASE PADMOUNTS			A	B	C	D	E	F	G	H
PAD	KVA	VOLTAGE	INCHES							
1PH	25-75	120/240	50	44	6	28	12	8	8	12
1PH2	100-167	120/240	58	44	6	28	14	8	8	12



**408C. CONCRETE PAD SPECIFICATIONS AND LAYOUT FOR THREE-PHASE, PAD-MOUNT TRANSFORMERS (CONTINUED)**

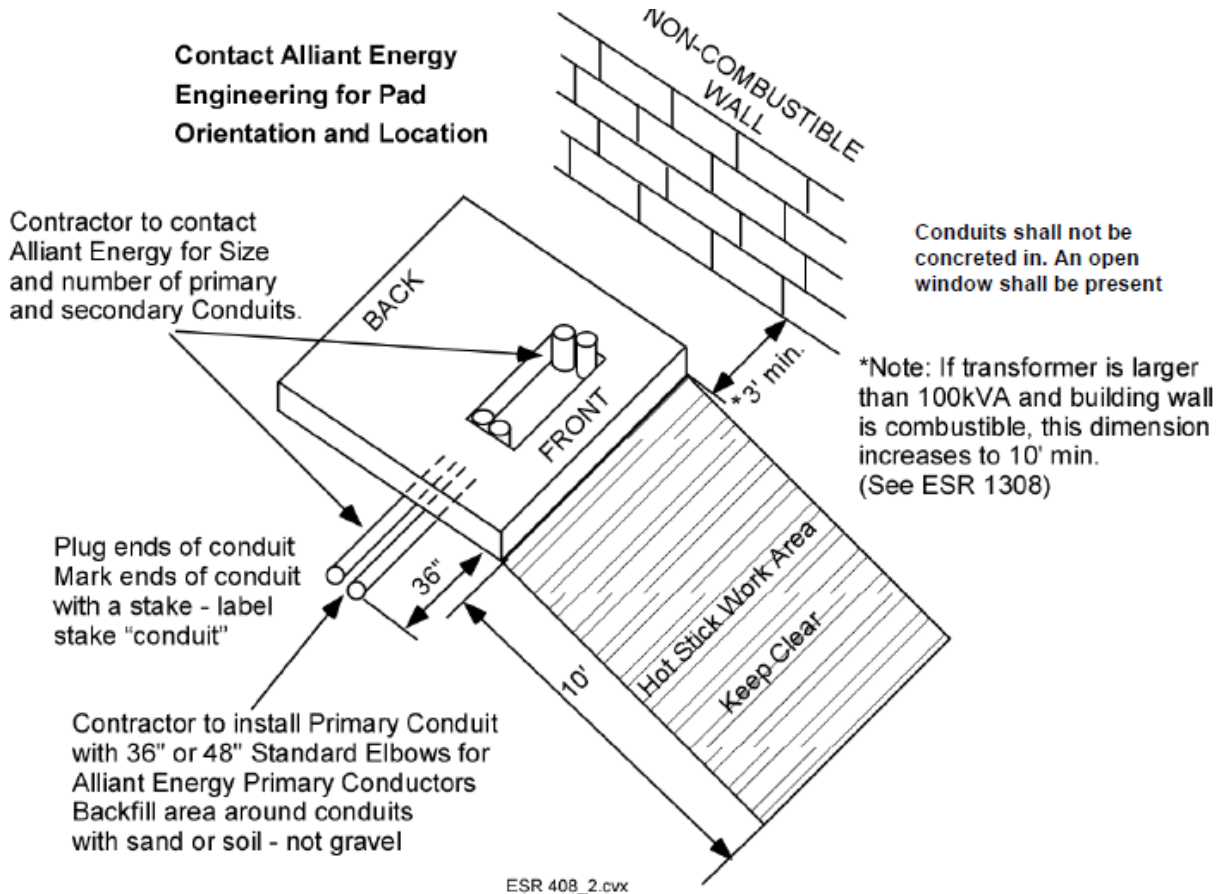

**NOTES:**

1. A clear space of 10 feet shall be maintained in front of the transformer to provide working space for hot-stick operation of the transformer and 3 feet on all other sides. Transformers or other pad-mounted equipment shall not be covered with decorative objects for the purpose of hiding the Alliant Energy equipment from public view.
2. Pad mounted metering transformer cabinets may be mounted on an isolated pad, adjacent to the transformer pad (ESR e-manual 408), or on a joint transformer and metering transformer cabinet pad (ESR e-manual 410) designed to accommodate conduit elbow sweeps.
3. All conduits shall enter through the window opening provided in the pad foundation. These conduits shall be cut off, so the top of the conduit is flush with the surface of the pad.
4. All metallic conduits shall be fitted with an insulating bushing.
5. When an oil sump is required, excavate 18 inches under and around the pad and fill with coarse crushed rock – check with the local building code to determine if an oil sump is required.
6. If structure is a farm building, see Chapter 8.



**409. CONCRETE SPECIFICATIONS AND LAYOUT FOR FOUNDATION WALL FOR THREE-PHASE, PAD-MOUNT TRANSFORMERS**

Stand-alone transformer pad, **ESR e-manual 408**, will sit on top of foundation walls detailed below. Foundations may be used where unstable soil conditions exist to avoid tilting of pad, or where a large number of secondary cables are required to provide a cable training area. Consult with Alliant Energy.

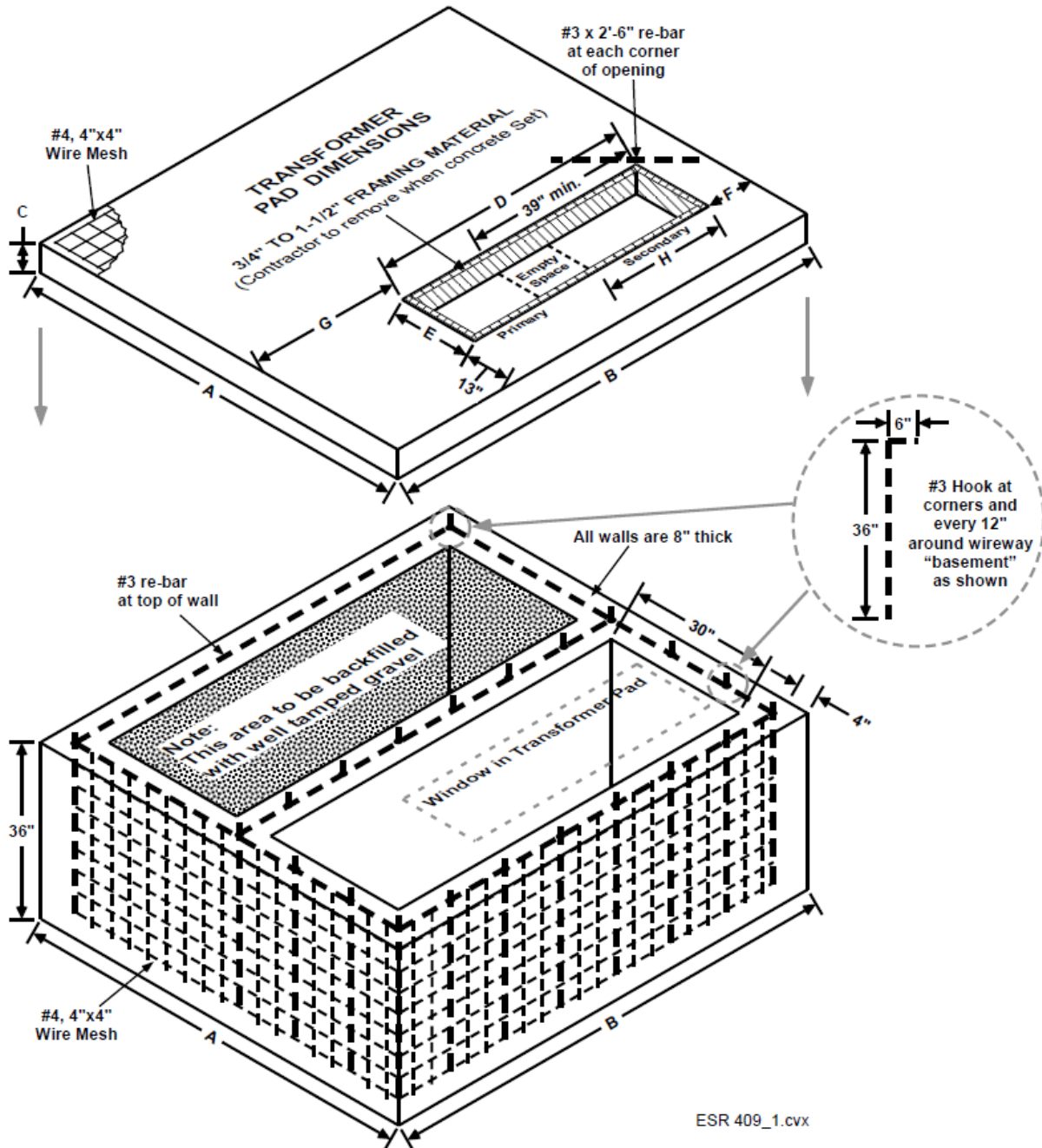

409. CONCRETE SPECIFICATIONS AND LAYOUT FOR FOUNDATION WALL FOR THREE-PHASE, PAD-MOUNT TRANSFORMERS (CONTINUED)

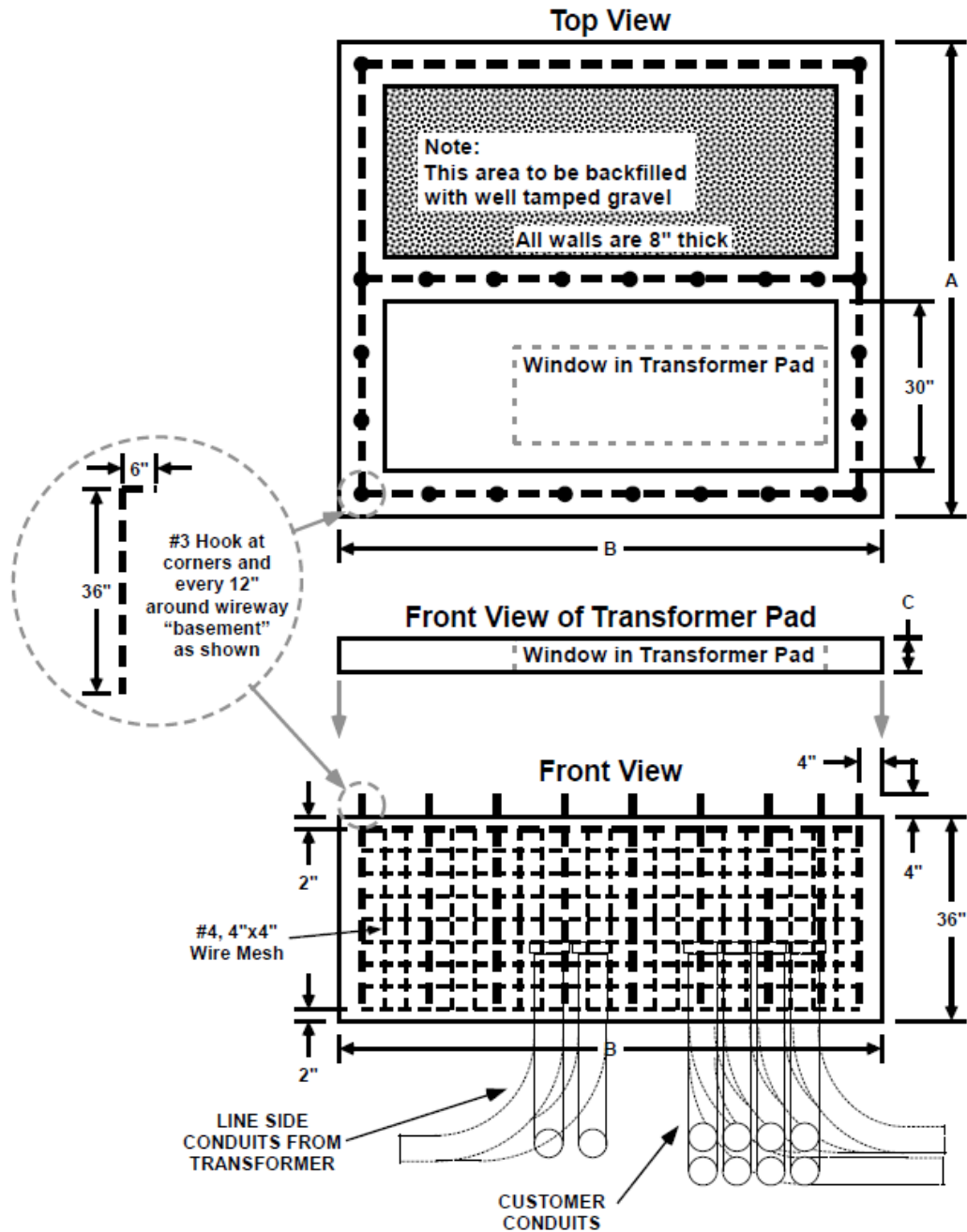

ESR 409\_2.cvx

NOTES:

1. Top of foundation walls shall be level.
2. Drainage around pad is sloped to allow liquids to flow away from any building.



**410. CONCRETE PAD SPECIFICATIONS AND LAYOUT FOR JOINT PAD THREE-PHASE, PAD-MOUNT TRANSFORMER AND METERING TRANSFORMER CABINET “BACK-TO-BACK DESIGN”**

- A. The customer/contractor shall contact Alliant Energy for sizes and number of primary and secondary conduits.
- B. A maximum of 8 secondary conduits are allowed.
- C. Pad shall rest on firm, well-compacted soil, free of organic or other undesirable materials.
- D. Concrete mix shall have a minimum strength of 4000 lb./sq. in. after 28 days.
- E. The top of the pad shall be level and all edges and corners rounded off.
- F. The pad shall be reinforced with #4 wire, 4” x 4” welded mesh or equivalent materials with additional 3/8-inch reinforcing rods around the cable opening. The mesh shall not be less than 1 inch from the edges and opening and 3" below the surface.
- G. If the #4 wire, 4"x 4" mesh is not available, two layers of #10 wire, 6"x 6" mesh, horizontally staggered, may be substituted for the #4 wire.
- H. Macro-Synthetic Fiber may be used in lieu of wire mesh. The fiber shall be installed per manufacturer specifications for minimum shrinkage and temperature reinforcement for slab on grade applications.
- I. Joint pad is an extension of Alliant Energy standard transformer pad (ESR e-manual 408).
- J. Pad dimensions vary based on Metering Transformer Cabinet used.
- K. For assistance with final pad dimensions, contact Alliant Energy Engineering.
- L. Joint pads are not allowed at farm installations where livestock may be present (see ESR e-manual 805).

**Informational Note: On a farm with livestock the Metering Transformer Cabinet and transformer are required to be on separate pads. This has to do with the potential of needing to install a neutral isolator. If using a shared pad, neutral isolation may be impacted by the metal reinforcing rods.**

	XFMR	SERVICE SIZE		KNOWN DIMENSIONS							
		208Y/120	480Y/277	A	B	C	D	E	F	G	H
PAD	KVA	AMPS		INCHES							
III	75-500	100-1200	100-600	84	96	6	55	17	10	31	22
IV	750-2500	1600-3000	800-3000	105	108	8	60	17	14	34	27

	XFMR	SERVICE SIZE		DIMENSIONS BASED ON METERING TRANSFORMER CABINET USED			
		208Y/120	480Y/277	W	X	Y	Z
PAD	KVA	AMPS		INCHES			
III	75-500	100-1200	100-600	Width of the cabinet minus 10 inches	Based on cabinet	60” + depth of the cabinet	A+Y
IV	750-2500	1600-3000	800-3000	Width of the cabinet minus 6 inches	Based on cabinet	60” + depth of the cabinet	A+Y

410. CONCRETE PAD SPECIFICATIONS AND LAYOUT FOR JOINT PAD THREE-PHASE, PAD-MOUNT TRANSFORMER AND METERING TRANSFORMER CABINET (CONTINUED)

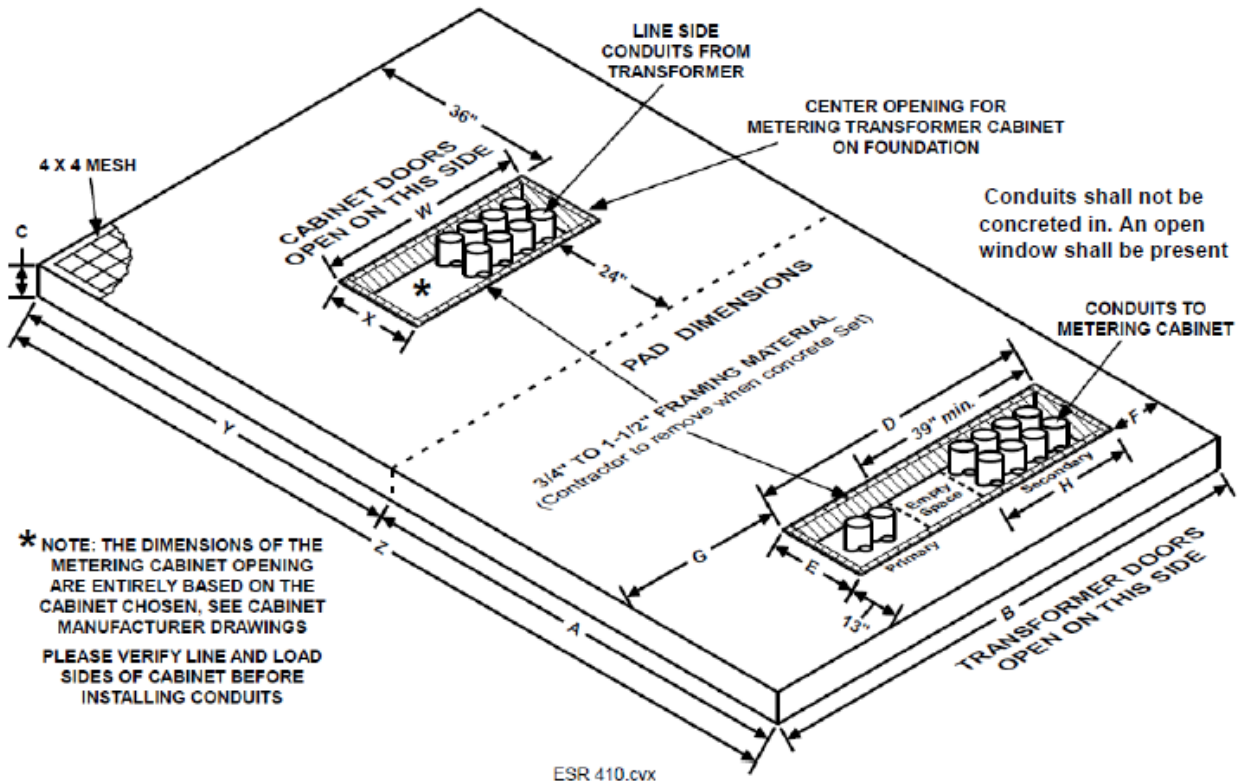

NOTES:

1. A clear space of 10 feet shall be maintained in front of the transformer to provide working space for hot-stick operation of the transformer and 3 feet on all other sides. Transformers or other pad-mounted equipment shall not be covered with decorative objects for the purpose of hiding the Alliant Energy equipment from public view.
2. Pad mounted metering transformer cabinets may be mounted on an isolated pad, adjacent to the transformer pad (ESR e-manual 408), or on a joint transformer and metering transformer cabinet pad (ESR e-manual 410) designed to accommodate conduit elbow sweeps.
3. All conduits shall enter through the window opening provided in the pad foundation. These conduits shall be cut off, so the top of the conduit is flush with the surface of the pad.
4. All metallic conduits shall be fitted with an insulating bushing.
5. When an oil sump is required, excavate 18 inches under and around the pad and fill with coarse crushed rock – check with the local building code to determine if an oil sump is required.
6. Not allowed for Agriculture use. Refer to Agriculture compliance team.



**411. CONCRETE PAD SPECIFICATIONS AND LAYOUT FOR CUSTOMER OWNED PAD FOR METERING/TERMINATION CABINET**

- A. The customer/contractor shall contact Alliant Energy for sizes and number of primary and secondary conduits.
- B. Pad shall rest on firm, well-compacted soil, free of organic or other undesirable materials.
- C. Concrete mix shall have a minimum strength of 4000 lb./sq. in. after 28 days.
- D. The top of the pad shall be level and all edges and corners rounded off.
- E. The pad shall be reinforced with #4 wire, 4” x 4” welded mesh or equivalent materials with additional 3/8 inch reinforcing rods around the cable opening. The mesh shall not be less than 1 inch from the edges and opening and 3" below the surface.
- F. If the #4 wire, 4"x 4" mesh is not available, two layers of #10 wire, 6"x 6" mesh, horizontally staggered, may be substituted for the #4 wire.
- G. Macro-Synthetic Fiber may be used in lieu of wire mesh. The fiber shall be installed per manufacturer specifications for minimum shrinkage and temperature reinforcement for slab on grade applications.
- H. Pad dimensions vary based on Metering Transformer Cabinet used.
- I. For assistance with final pad dimensions, contact Alliant Energy Engineering.

***Informational Note: On a farm with livestock the Metering Transformer Cabinet and transformer are required to be on separate pads. This has to do with the potential of needing to install a neutral isolator. If using a shared pad, neutral isolation may be impacted by the metal reinforcing rods.***

SERVICE SIZE		C	DIMENSIONS BASED ON METERING TRANSFORMER CABINET USED				
208Y/120	480Y/277		W	X	Y	B	
PAD	AMPS		INCHES				
	100-3000	400-3000	6”	Based on cabinet	Based on cabinet	X+36”+6”(min)	W+12”(min)

411. CONCRETE PAD SPECIFICATIONS AND LAYOUT FOR CUSTOMER OWNED PAD FOR METERING/TERMINATION CABINET (CONTINUED)

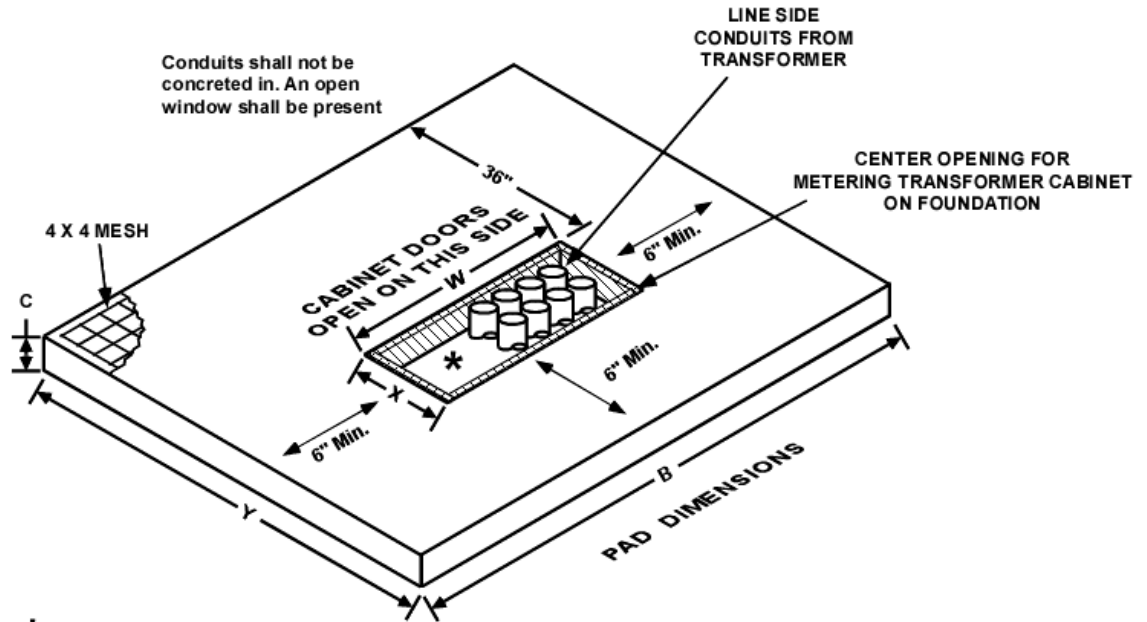

**\* NOTE: THE DIMENSIONS OF THE METERING CABINET OPENING ARE ENTIRELY BASED ON THE CABINET CHOSEN, SEE CABINET MANUFACTURER DRAWINGS**  
**PLEASE VERIFY LINE AND LOAD SIDES OF CABINET BEFORE INSTALLING CONDUITS**

**NOTES:**

1. A clear space of 10 feet shall be maintained in front of the transformer to provide working space for hot-stick operation of the transformer and 3 feet on all other sides. Transformers or other pad-mounted equipment shall not be covered with decorative objects for the purpose of hiding the Alliant Energy equipment from public view.
2. A clear space of 48" minimum will be maintained in front of the cabinet doors of the Metering/Termination Cabinet. The pad will extend 36" minimum from the cabinet doors of the Metering/Termination Cabinet.
3. All conduits shall enter through the window opening provided in the pad foundation. These conduits shall be cut off so the top of the conduit is flush with the surface of the pad.
4. All metallic conduits shall be fitted with an insulating bushing.



412. BOX PAD SPECIFICATION FOR THREE-PHASE, PAD-MOUNT TRANSFORMERS

		SERVICE SIZE									Max Weight
	XFMR	208Y/120	480Y/277	A	B	C	D	E	F	G	
PAD	KVA	AMPS		INCHES							LBS.
A	75-300	100-800	100-400	73	60	58	16	24	83	71	7000
B	500-750	1200-2500	600-1200	72	80	58	16	30	83	92	9000
C	1000-1500	3000	1600-2000	83	89	64	21	20	94	100	13000
D	2000-2500	N/A	2500-3000	85	122	75	21	20	96	133	21000

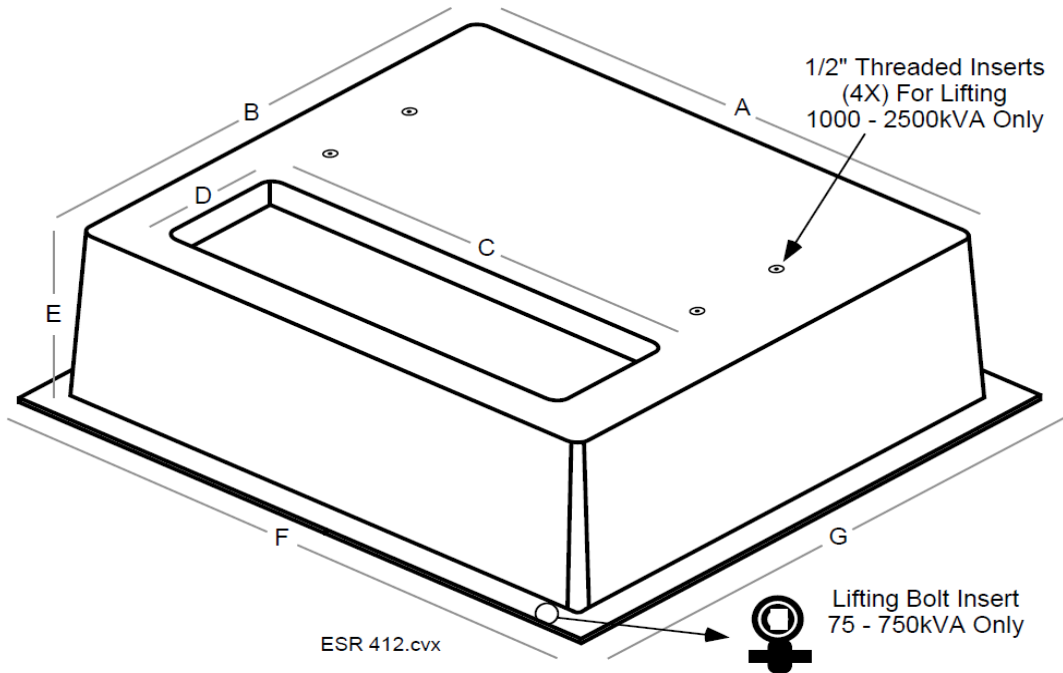

NOTES:

1. Customer furnishes and installs box-pad and customer provides and installs conduit. Alliant Energy may furnish three-phase box-pad at an additional cost to customer.
2. Refer to ESE e-manual Section E313 for box pad manufacturers.
3. Transformers should not extend over edges of box-pad. Larger transformers with cooling fins may require the larger box-pad.
3. A clear space of 10 feet shall be maintained in front of the transformer to provide working space for hot-stick operation of the transformer and 3 feet on all other sides.
4. Transformers or other pad-mounted equipment shall not be covered with decorative objects for the purpose of hiding the Alliant Energy equipment from public view.

**413. BOX PAD SPECIFICATION FOR SINGLE-PHASE, PAD MOUNT TRANSFORMERS**

		SERVICE SIZE								
		120/240V		A	B	C	D	E	F	G
PAD	XFMR	KVA	ITEM ID#	AMPS	INCHES					
I	25-50	121714	100-320	37	43	22	24	15	47	53
I-EX	25-50	100025	100-320	37	43	22	24	32	47	53
II	100-167	105500	400-800	37	52	22	24	15	47	62
II-EX	100-167	152199	400-800	37	52	22	24	32	47	62

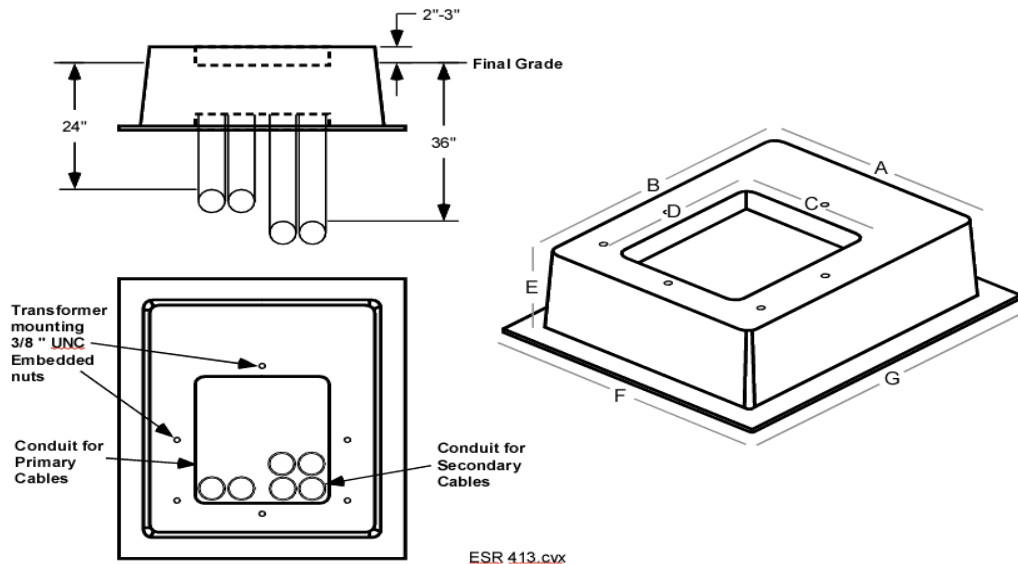

**NOTES:**

1. Alliant Energy furnishes and installs the box-pad, the customer provides and installs the conduit.
2. At Alliant Energy’s discretion, conduit elbows may be eliminated, and the customer may extend the conduit without elbows under the pad to the opening and install conduit bushings.
5. Contact Alliant Energy Engineering for size and number of conduits.
6. Box-pads come with 3/8-inch embedded nuts for bolting transformers to pad.
7. Transformers should not extend over edges of box-pad. Larger transformers with cooling fins may require the larger box-pad.
8. A clear space of 10 feet shall be maintained in front of the transformer to provide working space for hot-stick operation of the transformer and 3 feet on all other sides. Transformers or other pad-mounted equipment shall not be covered with decorative objects for the purpose of hiding the Alliant Energy equipment from public view.



Alliant Energy

# Chapter 5

Electric Service Rules

**RESERVED FOR NOTES:**



## CHAPTER 5

### ELECTRIC SERVICE RULES – DISTRIBUTED GENERATION

---

#### 500. SCOPE

This chapter includes distributed or customer-owned generation interconnected in parallel and operating with Alliant Energy’s electric distribution system. This is not a standalone chapter meaning all chapters of the ESR e-manual apply. For Optional Standby Generation see Chapter 12.

For all Distributed Generation (DG) installations, please contact Alliant Energy’s Renewable Hotline at 1-800-972-5325 or by email at [sellmypower@alliantenergy.com](mailto:sellmypower@alliantenergy.com). Customers may also visit [alliantenergy.com/sellmypower](http://alliantenergy.com/sellmypower).

#### 501. PERMISSION TO INTERCONNECT

DG interconnection may be an option for single and three phase customers. Characteristics of Alliant Energy’s electrical system vary by circuit. Not every size, voltage or type of generator can be interconnected at every location.

The customer shall supply Alliant Energy with the required electrical drawings and application for the proposed DG prior to installation. Alliant Energy may specify and require certain protective schemes based on the size, location and other factors of the generating unit proposed.

Alliant Energy considers the DG system size to be the sum of maximum possible AC kilowatt output of all inverters and all battery systems.

See ESR e-manual Section **107.F. Wiring Inspections**

#### 502. TECHNICAL INFORMATION

See [alliantenergy.com/sellmypower](http://alliantenergy.com/sellmypower) for technical information and requirements, applications, agreements and other additional resources.

#### **Additional Guidelines, Requirements & Code:**

- *Alliant Energy DER Technical Interconnection Requirements*
- *National Electrical Code (NEC)*
- *Electric Service Equipment (ESE e-manual)*

#### **IOWA Only**

- Iowa Administrative Code: Utilities Division [199]
  - Chapter 15 – Cogeneration and Small Power Production
  - Chapter 45 – Electric Interconnection of Distributed Generation Facilities

#### **WISCONSIN Only**

- Wisconsin State Legislature (Wisconsin Administrative Code)
  - Chapter PSC 119 – Rules For Interconnecting Distributed Generation Facilities

**503. METERING EQUIPMENT**

- A. Alliant Energy shall meter DG facility based on ESR e-manual Chapters 6 and/or 10.
- B. A bi-directional meter is required at all DG facilities to properly meter forward and reverse power flow. This may require a site visit by Alliant Energy metering personnel.
- C. Metering installations that fail to meet acceptable electrical standards as determined by Alliant Energy shall be modified and / or updated as required, such as indoor metering.
- D. Metering equipment may require replacement to accommodate DG metering.  
Such as, but not limited to:
  - 1. Round-ring sockets
  - 2. Rusted or damaged sockets or cabinets
  - 3. Sockets or cabinets with inadequate internal or external clearances
  - 4. Meters without the ability to bypass.
- E. Modifying or installing lugs in a meter socket, pedestal or metering transformer cabinet other than what is listed on the manufacturer's drawing associated with the UL Listing is not allowed.
- F. Metering equipment shall be accessible to Alliant Energy personnel. Accessible means the metering equipment shall be capable of being reached/accessed for programming, reading, probing, inspection and service without climbing, removing obstacles, utilizing ladders, entering locked areas, etc. Metering equipment that is not readily accessible will be required to be made accessible by the customer before interconnection of DG will be allowed.

**504. ALLIANT ENERGY DISTRIBUTION SYSTEM**

All modifications and additions to Alliant Energy's electrical distribution system in order to accommodate distributed generation facilities will be at the customer's expense.

**505. PRIMARY METERING CUSTOMERS WITH DG**

All primary metered customers shall meet the requirements of ESR e-manual Chapter 10. Contact Alliant Energy for requirements related to specific installation of DG facilities on a primary service.

**506. DELTA CONNECTED CUSTOMERS WITH DG**

All 3 PH delta connected customers may be required to upgrade to a Grounded WYE – Grounded WYE system to allow installation of DG on the premise.

**507. OPTIONAL STANDBY GENERATOR USED WITH DG**

Where a customer operates both distributed generation and an optional standby generator, they shall install a lockable, visible break interconnection disconnect switch, as shown in ESR e-manual 523 and 524.

**508. ELECTRICALLY ISOLATED ARRAYS**

For two PV systems that are electrically isolated, there shall be a minimum distance of 12 feet between the two arrays.

**509. LABELING REQUIREMENTS**

- A. It is the responsibility of the customer to comply with any and all labels required by the *NEC* or other jurisdictional codes and requirements.
- B. Customer shall provide and install a “Dual Power Source” label at the meter socket indicating the operating voltage, maximum current and maximum power of the DG system that is installed. Customer shall provide an “Interconnection Disconnect Switch” label at the DG disconnect. Example labels shown below:

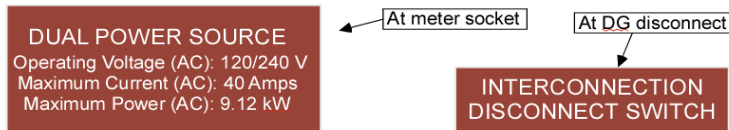

- C. Permanent labeling is required; Labeling shall be rigid engraved plastic, engraved self-sticking brass or engraved self-sticking aluminum.
- D. Labeling shall use a minimum of ¼ inch block lettering. Permanent labeling shall be installed to prevent damage and destruction of the labeling. Installation of labeling shall not limit access to the metering.
- E. Machine engraved with uniform numbers and lettering.

**510. POINT OF INTERCONNECTION**

- A. Preferred Methods
  1. DG connected via properly sized sub-breaker downstream from the main in-service panel
  2. Meter socket with Main (See ESE e-manual E102 and E106)
  3. Meter socket with factory installed dual lugs, 320A (See ESE e-manual E106B)
  4. Attached to metering transformer cabinet with available lugs
- B. Permitted when connecting DG on the line side of customer’s service entrance overcurrent protective device (Breaker/Fuse) Refer to drawing 514 and 521.
  1. Properly sized UL Listed NEMA 3R sealable bussed gutter must be installed outside
  2. Properly sized UL Listed NEMA 3R Termination Box must be installed outside
- C. Not Permitted when connecting DG on the line side of customer’s service entrance overcurrent protective device (Breaker/Fuse).
  1. Splices
  2. Split bolts
  3. Tap connectors
  4. Insulation piercing connectors
  5. Installing more cables than lugs are designed to handle
  6. Modifying or installing lugs on any equipment on the line side of the overcurrent protective device, other than what is listed on the manufacturer’s drawing associated with the UL Listing
  7. Any other modifications to meter sockets or metering transformer cabinets

**511. INTERCONNECTION DISCONNECT SWITCH (DISCONNECTION DEVICE) REQUIREMENTS**

- A. A device capable of disconnecting DG facilities from the electrical distribution system shall be installed at every DG site. All single throw disconnect switches shall be connected such that their blades are de-energized when the switch is in the open position.
1. Disconnection devices are considered easily visible and adjacent: for a home or business, up to ten feet away from the meter and within the line of sight of the meter, at a height of 30 inches to 72 inches above final grade.

**Informational Note: The back side of a field-built structure or around the corner of a building is not considered to be visible from the electric meter.**

2. In Wisconsin, the disconnection device should be located within 10 feet of the utility electric meter on residential and single building structures. Disconnection device shall be located in an accessible location. If the disconnection device cannot be located within 10 feet of the utility electric meter, a permanent placard shall be installed on the meter socket indicating the location of the interconnection disconnect switch and distance in feet from the meter to the disconnection device.
- B. Disconnection device shall be mounted at a height between 30 and 72 inches. Interconnection disconnect switch shall have a minimum of 6" vertical and horizontal separation from all other electrical equipment, non-electrical equipment, and all other obstructions. If these requirements cannot be met, they can be reviewed by Alliant Energy.
- C. Disconnection device shall open with a visual break, be able to be locked open, be capable of disconnecting and de-energizing distributed generation and shall conform to technical guidelines and state requirements.
- D. The disconnection device should disconnect DG only and should not disconnect any load.
- E. Any DG connection on the line side of the main service disconnect(s) shall have a service entrance rated disconnect switch with overcurrent protection
- F. The DG facility shall only be interconnected with a single metered service, see ESR e-manual 109.

**Informational Note: This means customer is NOT allowed to feed DG from one building's electrical system into another buildings electrical system when the two buildings are fed from separate metered electrical services.**

**G. Farm Services utilizing a Site-Isolating Device**

DG interconnections shall not be allowed on the line side of the site-isolating device as defined by NEC 547.9.

**H. Large Area Facilities with Multiple Buildings fed from main service panel or sub-panel**

1. For facilities covering a large area with multiple or remote buildings that require electric service, the disconnection device may be up to 30 feet away from the meter and within the line of sight of the meter, at a height of 30 inches to 72 inches above final grade. A permanent placard shall be installed at the meter socket indicating the location of the interconnection disconnect switch and distance in feet from the meter to the disconnection device. For example, corporate & college campuses, Industrial facilities, manufacturing facilities, etc.
2. Main disconnection device for remote building may be used as the disconnection device at the meter. However, a separate DG only disconnect is recommended on the exterior of the remote building at the DG location.

**Informational Note:** *The 10 ft. and 30 ft. distance requirements for Iowa along with the disconnection device mounting heights come from Iowa Administrative Code 199-45.*

**512. BATTERY ENERGY STORAGE SYSTEMS**

- A. Due to the requirements of Chapter 45 of the Iowa Administrative Code, in Iowa the interconnection disconnect switch (device) should not disconnect the main service entrance. The disconnection device may disconnect load fed from or supplied by a battery energy storage system.
- B. Battery energy storage systems shall use UL 1741 utility-interactive inverters. Energy storage system transfer devices are subject to the same requirements as standby generation systems, see ESR e-manual Chapter 12.
- C. Battery and DG System combinations will require a lockable, visible disconnect between the meter and battery and DG system combinations.

**513 - 525. DRAWINGS**

Sample one-line diagrams are shown in 512 – 524; consult Alliant Energy for any installations not covered in these diagrams.

**Informational Note:** *Utility meter and service lateral or drop are furnished and installed by Alliant Energy, all other equipment shown is furnished and installed by customer.*

513. 1-PHASE/3-PHASE, SELF-CONTAINED, SINGLE LUG

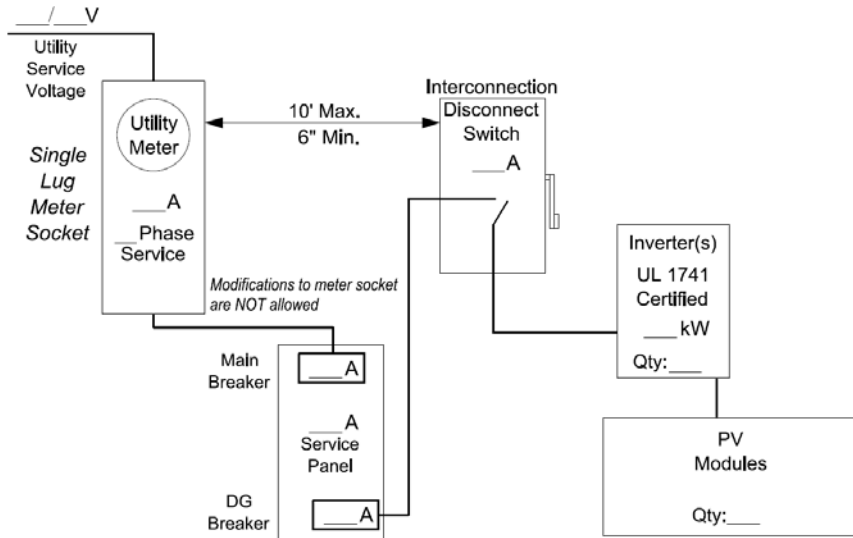

ESR511.dgn

514. 1-PHASE/3-PHASE, SELF-CONTAINED, SINGLE LUG UL LISTED GUTTER, OR UL LISTED TERMINATION BOX

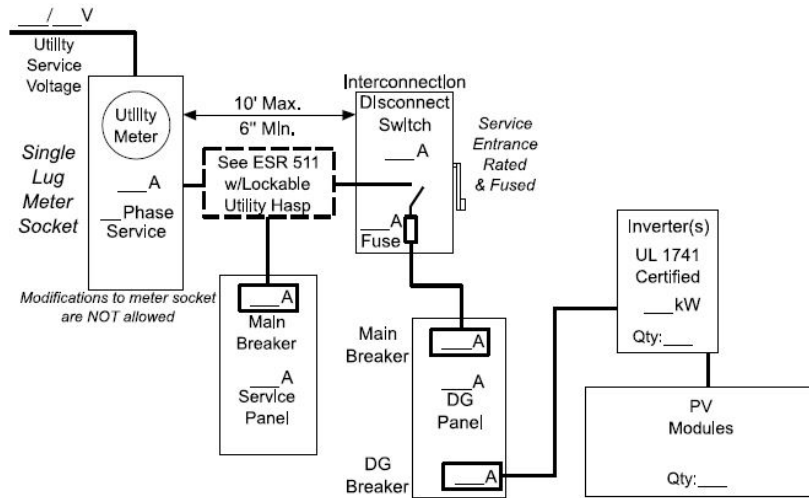

ESR512.dgn

Notes:

- If DG Panel serves any load, the rated ampacity of the service panel main breaker plus the rated ampacity of the Interconnection Disconnect Switch fuse shall not exceed the rated ampacity of the utility meter.
- If DG Panel serves DG only, neither the rated ampacity of the service panel main breaker nor the rated ampacity of the Interconnection Disconnect Switch fuse shall exceed the rated ampacity of the utility meter.

515. 1-PHASE/3-PHASE, SELF-CONTAINED, APPROVED ALTERNATE ENERGY METER SOCKET, 200 AMP MAIN, 60-70 AMP DG BREAKER (SEE ESE e-manual E106A)

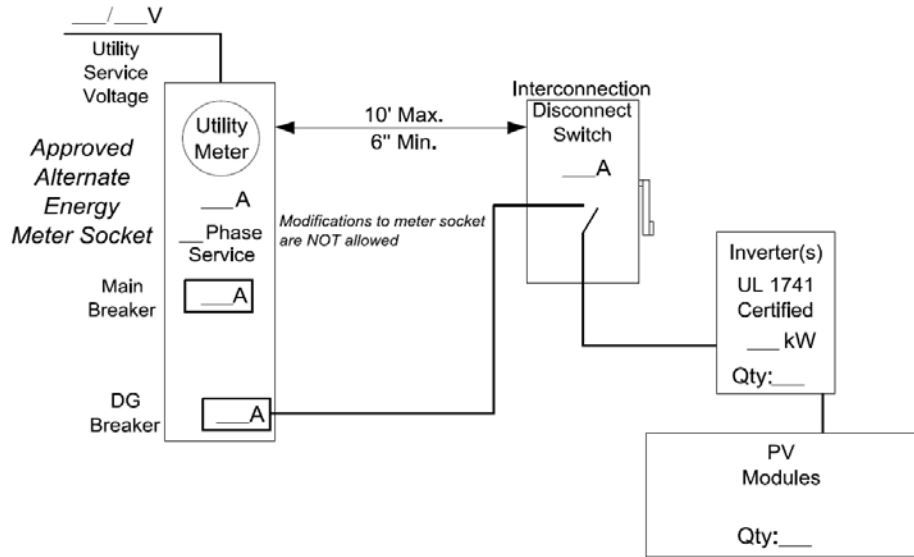

ESR513.dgn

516. 1-PHASE/3-PHASE, SELF-CONTAINED, APPROVED DUAL LUG METER SOCKET (SEE ESE e-manual E106B)

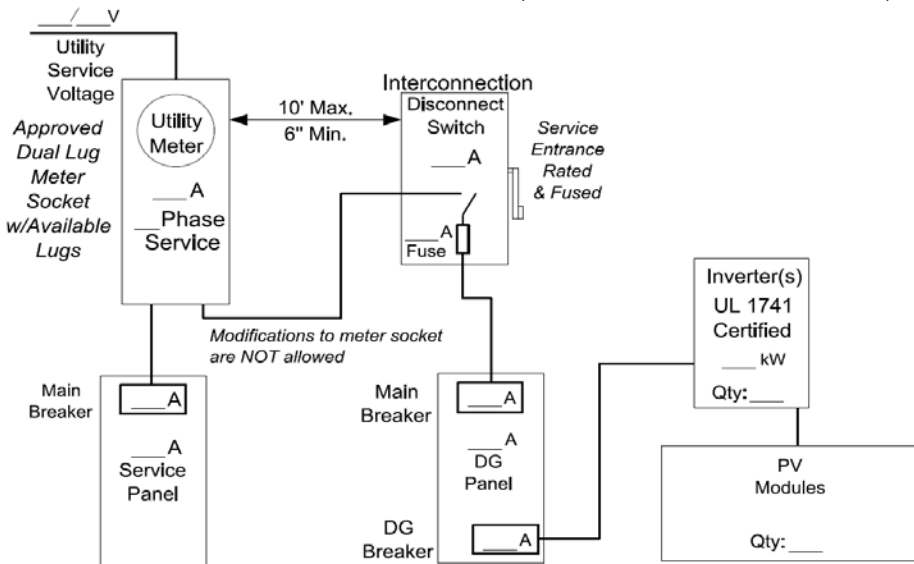

ESR514.dgn

Notes:

- If DG Panel serves any load, the rated ampacity of the service panel main breaker plus the rated ampacity of the Interconnection Disconnect Switch fuse shall not exceed the rated ampacity of the utility meter.
- If DG Panel serves DG only, neither the rated ampacity of the service panel main breaker nor the rated ampacity of the Interconnection Disconnect Switch fuse shall exceed the rated ampacity of the utility meter.



517. 1-PHASE/3-PHASE, SELF-CONTAINED, SINGLE LUG  
REMOTE BUILDING WITH DG > 30' FROM METER

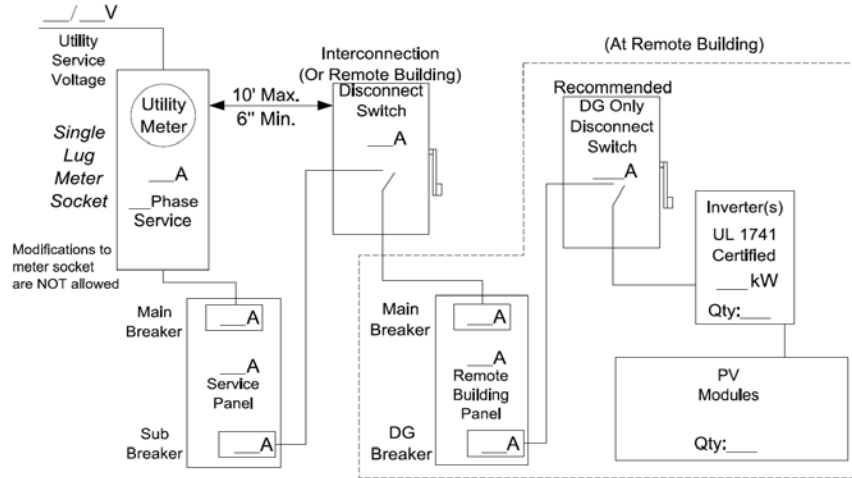

ESR 515.dgn

518. 1-PHASE/3-PHASE, SELF-CONTAINED, DUAL LUG  
REMOTE BUILDING WITH DG > 30' FROM METER (SEE ESE e-manual E106B)

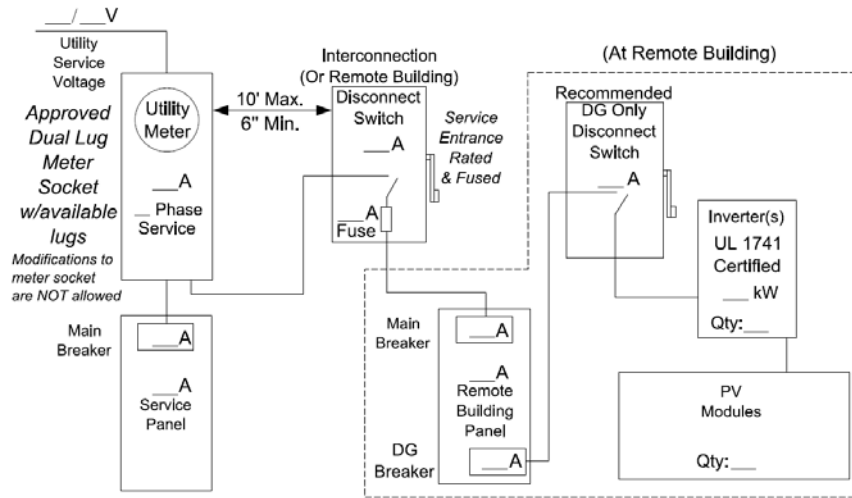

ESR516.dgn

Notes:

- If the Remote Building Panel serves any load, the rated ampacity of the service panel main breaker plus the rated ampacity of the Interconnection Disconnect Switch fuse shall not exceed the rated ampacity of the utility meter.
- If the Remote Building Panel serves DG only, neither the rated ampacity of the service panel main breaker nor the rated ampacity of the Interconnection Disconnect Switch fuse shall exceed the rated ampacity of the utility meter.

519. 1-PHASE/3-PHASE, METERING TRANSFORMER CABINET

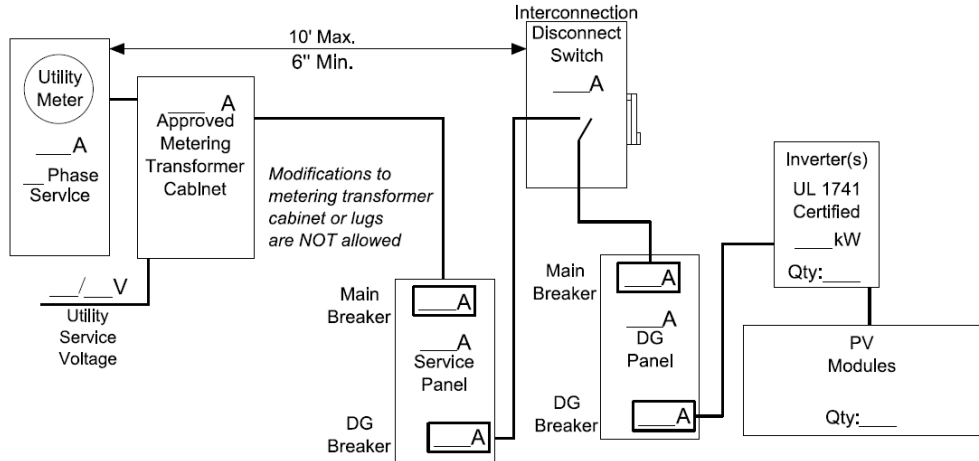

ESR517.dgn

520. 1-PHASE/3-PHASE, METERING TRANSFORMER CABINET, WITH AVAILABLE LUGS IN METERING TRANSFORMER CABINET

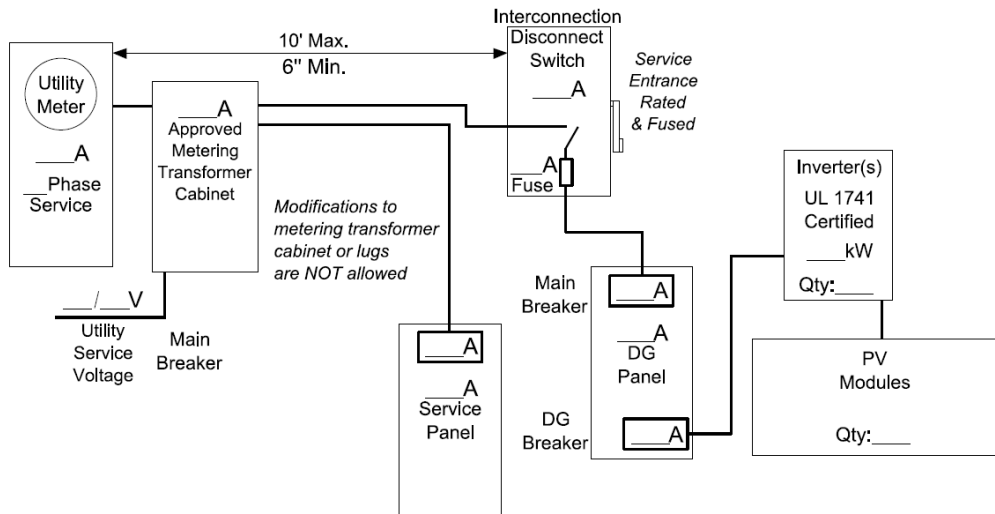

ESR518.dgn

Notes:

- If DG Panel serves any load, the rated ampacity of the service panel main breaker plus the rated ampacity of the Interconnection Disconnect Switch fuse shall not exceed the rated ampacity of the metering transformer cabinet.
- If DG Panel serves DG only, neither the rated ampacity of the service panel main breaker nor the rated ampacity of the Interconnection Disconnect Switch fuse shall exceed the rated ampacity of the metering transformer cabinet.

521. 1-PHASE/3-PHASE, METERING TRANSFORMER CABINET, SINGLE LUG, UL LISTED BUSSED GUTTER OR UL LISTED TERMINATION BOX

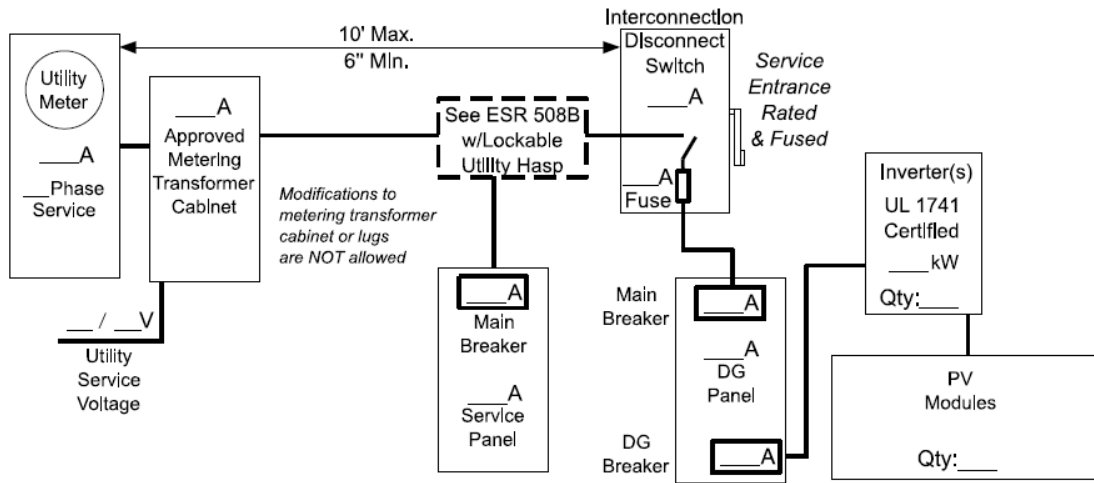

ESR519.dgn

Notes:

- If DG Panel serves any load, the rated ampacity of the service panel main breaker plus the rated ampacity of the Interconnection Disconnect Switch fuse shall not exceed the rated ampacity of the metering transformer cabinet.
- If DG Panel serves DG only, neither the rated ampacity of the service panel main breaker nor the rated ampacity of the Interconnection Disconnect Switch fuse shall exceed the rated ampacity of the metering transformer cabinet.

ELECTRIC SERVICE RULES

DISTRIBUTED GENERATION

Issued Jan 2024

522. 1-PHASE/3-PHASE, METERING TRANSFORMER CABINET, REMOTE BUILDING WITH DG > 30' FROM METER

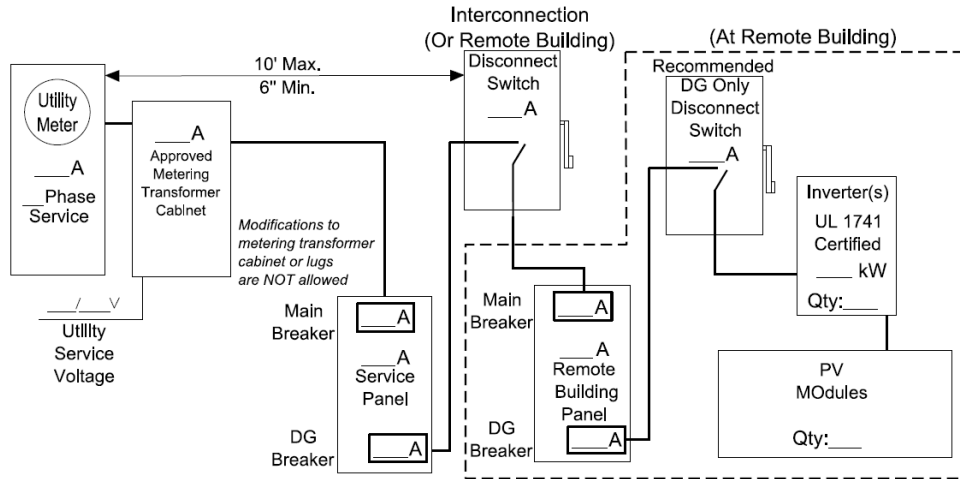

ESR520.dgn

523. 1-PHASE/3-PHASE, METERING TRANSFORMER CABINET, REMOTE BUILDING WITH DG > 30' FROM METER

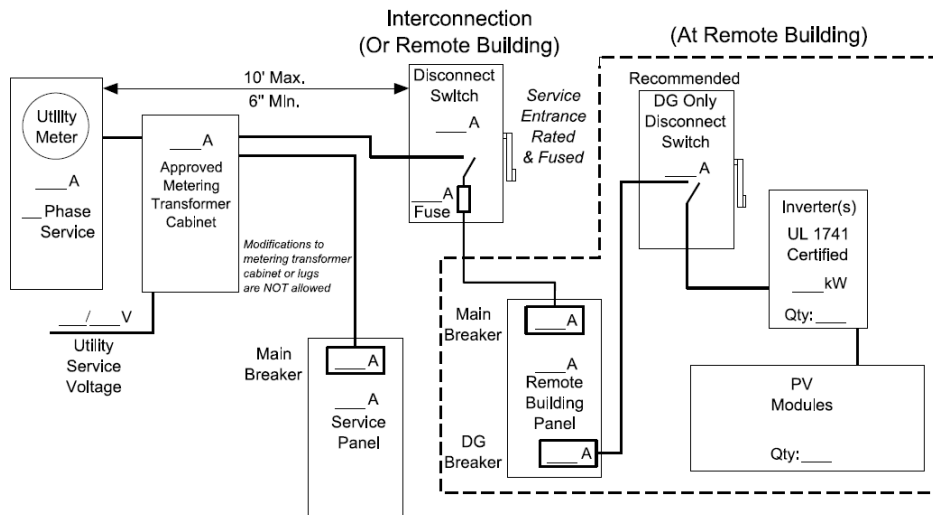

ESR521.dgn

Notes:

- If the Remote Building Panel serves any load, the rated ampacity of the service panel main breaker plus the rated ampacity of the Interconnection Disconnect Switch fuse shall not exceed the rated ampacity of the metering transformer cabinet.
- If the Remote Building Panel serves DG only, neither the rated ampacity of the service panel main breaker nor the rated ampacity of the Interconnection Disconnect Switch fuse shall exceed the rated ampacity of the metering transformer cabinet.

524. 1-PHASE/3-PHASE, SELF-CONTAINED, SINGLE LUG + BATTERY STORAGE SYSTEM (ENTIRE SERVICE BACKUP)

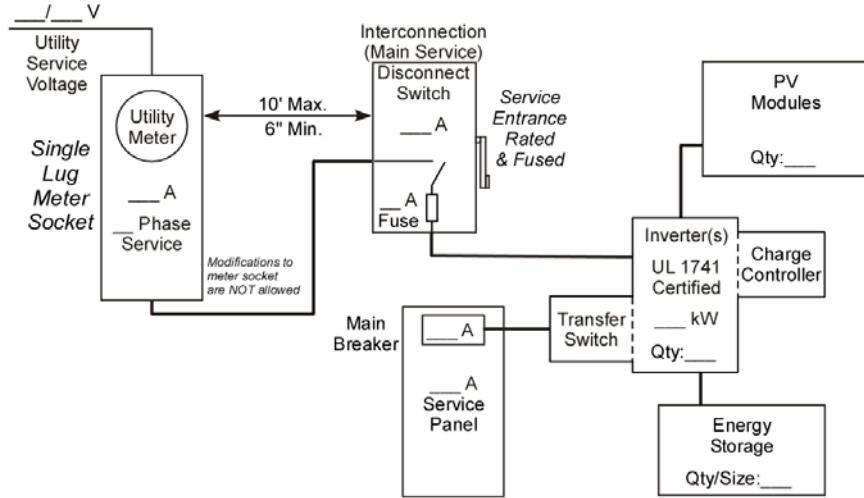

ESR 522(W).CVX

525. 1-PHASE/3-PHASE, SELF-CONTAINED, SINGLE LUG + BATTERY STORAGE SYSTEM LOAD PANEL

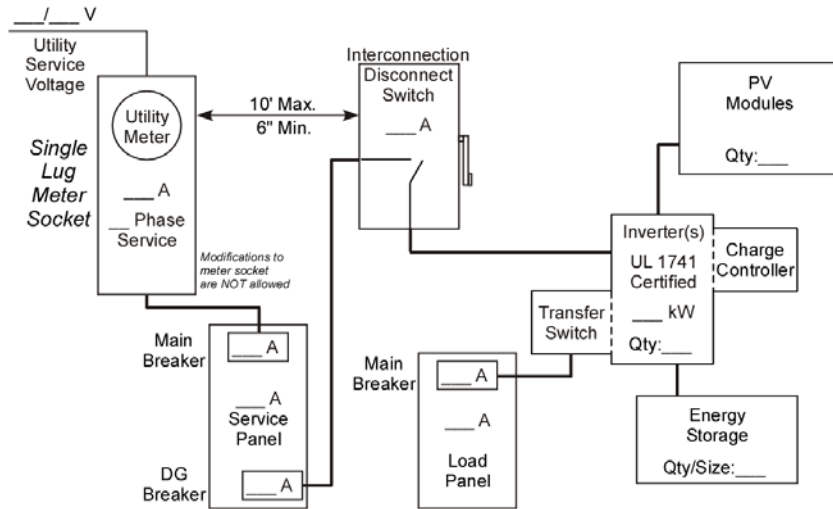

ESR 523.CVX

Wisconsin Notes:

- If a battery energy storage system is a backup to the service entrance main, the rated ampacity of the Interconnection Disconnect Switch fuse shall not exceed the rated ampacity of the utility meter.
- If a battery energy storage system is a backup to a load panel, the rated ampacity of the service panel main breaker shall not exceed the rated ampacity of the utility meter.

Iowa Notes:

- If a battery energy storage system is a backup to a load panel, the rated ampacity of the service panel main breaker shall not exceed the rated ampacity of the utility meter.

Alliant Energy

# Chapter 6

Electric Service Rules

**RESERVED FOR NOTES:**



## ELECTRIC SERVICE RULES

### SECONDARY METERING

Issued Jan 2024

## CHAPTER 6

### ELECTRIC SERVICE RULES – SECONDARY METERING

---

#### 600. METERING FACILITIES

- A. Meter sockets are required on all services except special cases outlined in Alliant Energy rates.
- B. Residential customers may use a residential or commercial meter-socket. Commercial, farm and non-residential customers shall use a commercial meter socket.
- C. All meters located on a commercial property shall meet commercial requirements.
- D. For installations requiring instrument transformers (potential or voltage transformers, PTs, and current transformers, CTs) a “metering transformer cabinet” will be required. These metering transformer cabinets can also be commonly referred to as instrument transformer cabinets or current transformer (CT) cabinets.
- E. All outdoor service raceway or cable connections to meter-socket bases, meter enclosures, metering transformer cabinets and/or switches, shall be minimum NEMA Type 3R.
- F. Meter assemblies that contain breakers must meet short Circuit Current Rating (SCCR), Fault Current Ratings and Amperage Interrupting Current (AIC), if the meter assembly does not contain breakers, these ratings do not apply.
- G. For more information on Alliant Energy meter socket, pedestal, enclosure and cabinet requirements and approved equipment listings see Electric Service Equipment (ESE) e-manual.
- H. Splices are not allowed in meter sockets, pedestals, or cabinets.
- I. Metering equipment shall not be used as a raceway unless designed with such provisions.
- J. It is not permitted to modify or install lugs in a meter socket, pedestal, or metering transformer cabinet other than what is listed on the manufacturer’s drawing associated with the UL Listing.

#### 601. LOCATION OF METERS

- A. Alliant Energy shall pre-approve the location of all meters and metering equipment. The metering equipment shall be accessible at all times to Alliant Energy representatives.
- B. Meter sockets and pedestals shall be installed outdoors securely fastened to a building, structure, or foundation. A free-standing meter pedestal with a stabilization footing may be used where no substantial buildings are available. Metering transformer cabinets and termination cabinets shall be installed outdoors securely fastened to a building, structure, or foundation.
- C. When used for metering purposes, Alliant Energy prefers all yard pole meters, field built metering structures or free-standing metering pedestals to be installed so the meter faces an area (usually a driveway) that will accommodate motor vehicle access to the meter.
- D. If a self-contained meter is installed at a location other than a building or farm distribution center, then over current protection and grounding are required at the metering point.
- E. See ESR Section 606.A. for indoor metering requirements.

602. METERING INSTALLATIONS

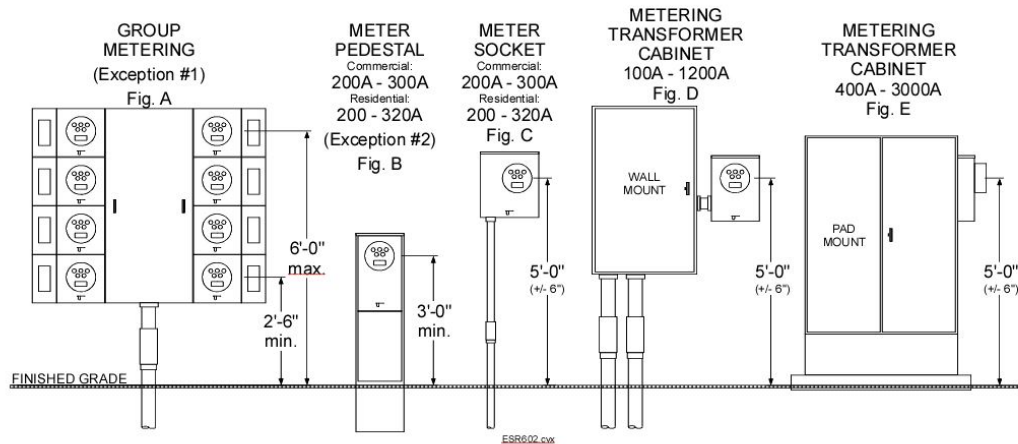

A. Equipment

1. Customer furnishes and installs:
  - Meter-sockets
  - Ganged meter sets.
  - Metering transformer cabinets
  - Cable tray or raceway
  - 1" rigid galvanized conduit for instrument transformer wiring
  - Any other related metering equipment
2. Alliant Energy furnishes and installs:
  - Meters
  - Instrument transformers (CTs and PTs)
  - Instrument transformer wiring

B. Meter socket mounting devices shall be securely fastened to the supporting building or structure with non-corrosive fasteners. Conduits and cables shall not be used to support wall-mounted devices. Meter sockets or cabinets shall not be installed where they will be exposed to mechanical damage, excessive dust, excessive moisture, corrosive vapors, or vibrations.

C. When mounting meter socket to side of metering transformer cabinet self-taping screws will not be permitted, it shall be through bolted.

D. Customer-owned equipment shall not be installed in any cabinets that are sealed by Alliant Energy, see ESR Section 604.

E. All sockets shall be inspected and approved by Alliant Energy to ensure they meet our requirements. Alliant Energy will not approve the use of altered, rusted, damaged or modified equipment.



F. Meters and metering devices shall be mounted plumb such that the center of the meter is approximately 5' (+/-6") above the final grade except as follows:

**Exception No. 1** – Group metering shall be mounted such that meter centers are between 2'-6" and 6'-0" above final grade.

**Exception No. 2** – Outdoor wall-mounted, or free-standing meter pedestals shall be mounted such that meter centers are a minimum of 3'-0" above final grade.

**Exception No. 3** – Customer may submit a variance to standard height requirements when in an area that has potential for flooding.

**Exception No. 4** – Customer may submit a variance to height requirements when located within 100-year flood plain areas before any electrical work has begun. The customer shall supply 100-year flood plain documentation for the location and a design that conforms to OSHA Standards 1926.1052 and 1910.23 with the variance request. Alliant Energy engineering will not approve any meter heights higher than 3'-0" above the 100-year flood plain levels. Required workspace as listed in ESR Section 606 shall be maintained on this and all meter installations.

### 603. IDENTIFICATION OF METERS

For multiple metering installations, each meter position shall be marked with the address or unit number of the location served on the outside of the socket or by the breaker. This marking shall also be placed on the corresponding distribution panel(s). The external marking shall be a permanent self-sticking brass or engraved rigid plastic label with minimum 1/2" block letters or numbers. It shall be machine engraved with uniform numbers and lettering. A permanent marking shall also be inside the meter-socket base in a visible location when the cover is removed. Alliant Energy will not install meters until this requirement is met.

### 604. METER SEALS

Alliant Energy will seal all meters, meter facilities and points of access to un-metered wiring on the customer's premises. All cabinets, conduit fittings and equipment enclosures containing un-metered conductors shall be made sealable before the service is energized. It is illegal for customers or contractors to remove meters or seals. Contact Alliant Energy if access to any Alliant Energy sealed cabinet is required. Violation of this rule could result in immediate disconnection, diversion charge and prosecution.

### 605. SEPARATION OF METERED AND UN-METERED CONDUCTORS

- A. Metered conductor shall not be enclosed with un-metered conductor in the same raceway or cable tray, except as required in sealed meter equipment assemblies: meter sockets, meter pedestals and metering transformer cabinets.
- B. If a metering transformer cabinet is equipped with an internal or external raceway meant for metered conductors, the customer shall use this raceway to maintain separation from un-metered conductors. The customer shall also install their conduits beneath this raceway.
- C. Where metered circuit conductors are run parallel to un-metered service entrance conductors, they shall be at least 6 inches apart at their termination where not in conduit and exposed, such as weather heads.

- D. Line and load conductors shall not cross each other.
- E. The customer shall not install accessible fittings (e.g. LB, box, etc.) in conduit risers that enclose un-metered service conductors.

**606. CLEARANCE REQUIREMENTS FOR METERING EQUIPMENT**

Alliant Energy requires a minimum of 48” working space in front of each meter or metering transformer cabinet.

**UNOBSTRUCTED WORK AREA**

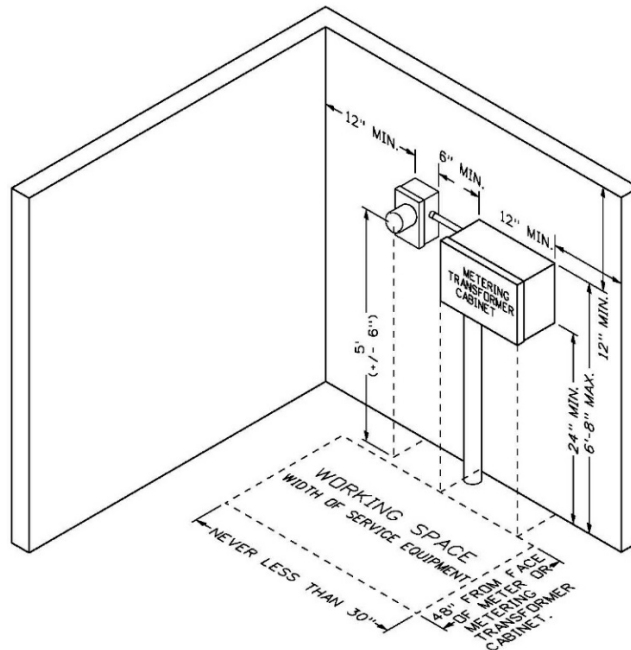

ESR 606.DGN

**NOTES:**

1. Workspace is measured out 48” from the face of the meter or door(s) of the cabinet and a minimum 30” wide.
2. A minimum 6” vertical and horizontal separation shall be maintained between metering equipment and other obstructions or non-metering equipment.
3. The space shall be large enough to allow the cabinet doors to open 90 degrees.
4. The space shall be clear from final grade to at least 6’-6” (8’-0” preferred) above the ground.
5. An area of at least 30” in width shall be provided to access the work area.
6. This work area shall not be used for storage.

**ELECTRIC SERVICE RULES**

**SECONDARY METERING**

Issued Jan 2024

**A. Indoor Metering Locations (VARIANCE REQUIRED)**

1. Alliant Energy requires all metering to be located outdoors. There may be a few exceptions. The exception will be pre-approved or the metering will be required to be outdoors.

**2. Indoor Metering Qualifications (Variance Required):**

**Review and approval of the proposed metering site is required prior to final building design. All such requests shall be submitted via variance request.**

- a) Where - it is impossible or impractical to install meter bases outside may be considered for indoor metering.
- b) With pre-approval, a set of requirements for the indoor metering room will be provided.

**607. METER SOCKET REQUIREMENTS**

Service Type	Phase	Wire	Voltage	Max. Amps	Terminals	Meter Form #
SELF-CONTAINED						
Single Phase - Commercial	1	3	120/240	300	4	2S
Single Phase - Residential	1	3	120/240	320	4	2S
Network Single Phase (1)	1	3	120/208	200	5	12S
Four Wire WYE	3	4	120/208	300	7	16S
CURRENT TRANSFORMER RATED						
Single Phase - IPL Only	1	3	120/240	20	5	3S
Single Phase - WPL Only	1	3	120/240	100	5	3S
Single Phase CT Cab. - IPL Only	1	3	120/240	20	6	4S
Four Wire WYE	3	4	120/208	20	13	9S
Four Wire WYE	3	4	277/480	20	13	9S
MAINTENANCE ONLY						
Single Phase CT Cab. (2)	1	3	120/208	20	8	5S/45S
Four Wire Delta (3)	3	4	120/240	20	13	9S
Three Wire Delta (4)	3	3	120/240	20	8	5S/45S
Four Wire WYE OH Only	3	4	277/480	200	7	16S

- 1. Network Meters - The fifth terminal shall be installed horizontally in the nine o'clock position. Permanent or added fifth position terminals shall be of the screw-in-type, unless otherwise approved by Alliant Energy Engineering.



2. 8-terminal socket is for 120/208 1-phase network metering transformer cabinets for maintenance purposes only (Not for new installations).
  3. This meter socket is for 4-wire delta & 4-wire wye maintenance only.
  4. This meter socket is for 3 wire delta maintenance only.
- A.** Line and load side conductors entering a meter socket for underground service shall enter and leave the socket on opposite sides. Line conductors shall enter the socket on the bottom left side and the load conductors shall leave on the bottom right side of the socket. The center knockout in the bottom of the 320-amp socket shall only be used when it is necessary to accommodate the customer with a second conduit. The second conduit may only be installed if the lugs are rated for a second conductor or there are two sets of lugs. Preapproval from Alliant Energy Engineering is required to change this orientation.
- B.** Self-contained meters for commercial single and three-phase services shall not exceed loads of 300 amps. The maximum allowable amperage rating of 300 amps along with adjustable breaker and fuse or a combination guarantees the accuracy of the self-contained meters. Commercial service with loads greater than 300 amps shall use instrument-transformer rated meter.

**608. METERING EQUIPMENT SHIELD** The customer is responsible for protecting Alliant Energy’s meter(s) and customer’s own metering equipment from damage caused by falling ice, snow, or other objects. If protection is not provided for meter equipment by adequate roof overhang the customer shall construct a protective shield, or the metering equipment location shall be moved to a safe area. The customer will be charged for meter replacement if damage occurs and typically an outage will be required to replace any damaged equipment. An adequate roof overhang shall extend a minimum of 18”- 24” out from the face of the wall to which the meter is mounted.

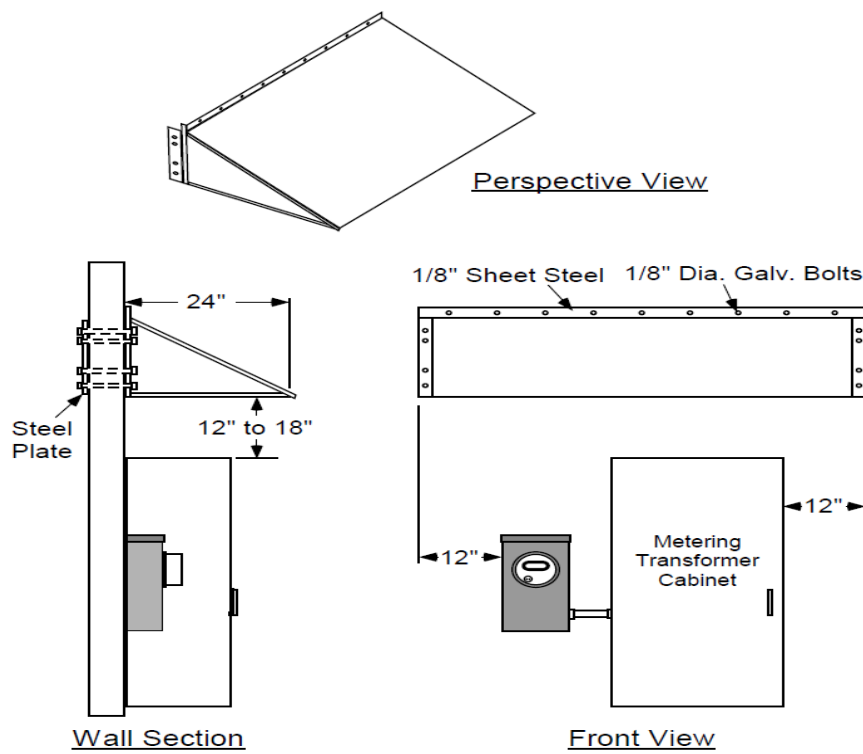

**NOTES:**

1. Steel to be primed and painted with rust-resistant paint.
2. Shield shall be capable of supporting 50 pounds.
3. Shield may be constructed of steel, treated wood or masonry. Thin sheet metal (tin) is not acceptable.
4. Shield to be so located as to not be a “head bumping” hazard.
5. Width of shield may vary depending on the number of meters being protected.

**609. OUTDOOR FREE STANDING (Field-Built) METER STRUCTURES**

- A. Field built structures are limited to 1200 Amp Maximum.  
Alliant Energy engineering approval is required for use.
- B. Wood field-built structures shall have a minimum of two 6" x 6" wood posts and 2" x 6" planks that are pressure treated against decay per the American Wood Protection Association (AWPA). The posts shall be buried a minimum of 4 feet deep, plumb and set in concrete the full depth. The planks shall be level and fastened with stainless steel or hot-dipped galvanized (G-185) hardware (bolts, washers, nuts.), **nails and screws are not acceptable.** The customer is responsible for the maintenance of the structure. See ESR 609.dgn for allowable design details.
- C. All service equipment shall be waterproof, lockable and listed by an approved testing agency for service entrance use. Shall be securely fastened to structure with through bolts, washers and nuts.

**WOOD CONSTRUCTION**

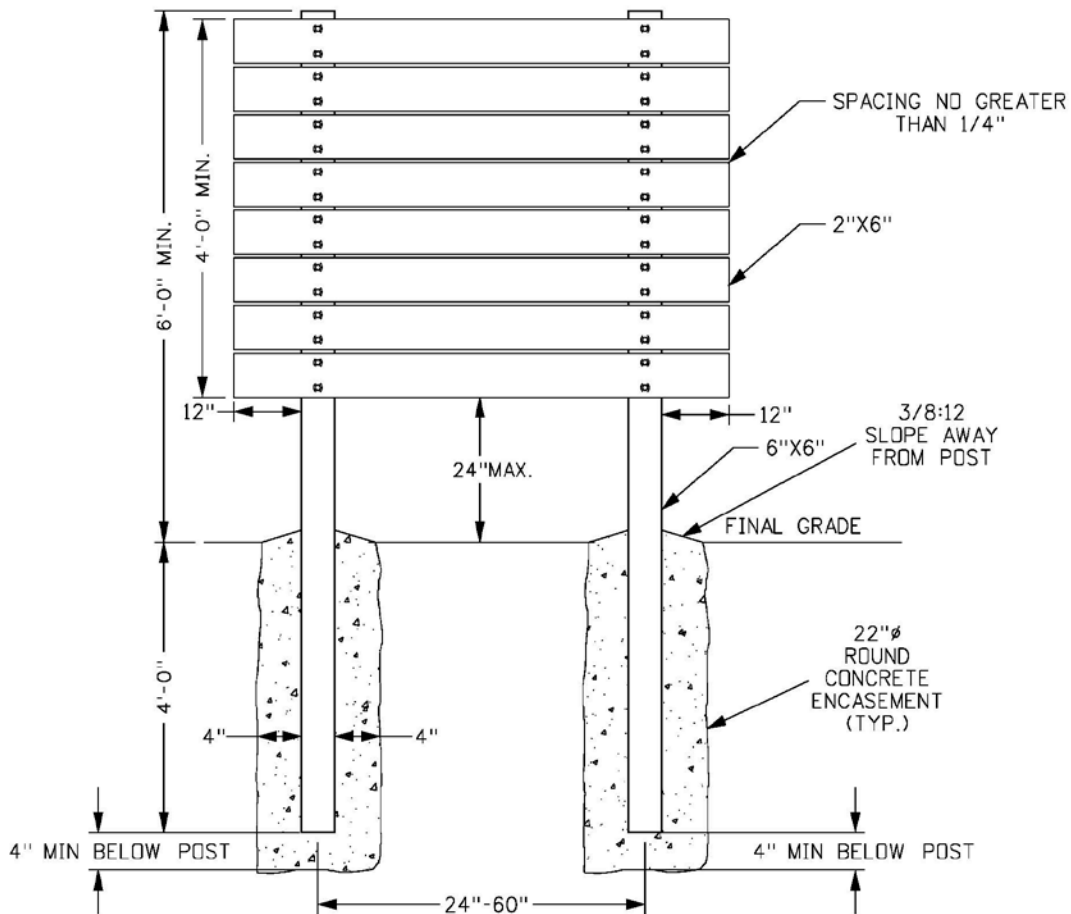

ESR 609.DGN

**STEEL POST CONSTRUCTION**

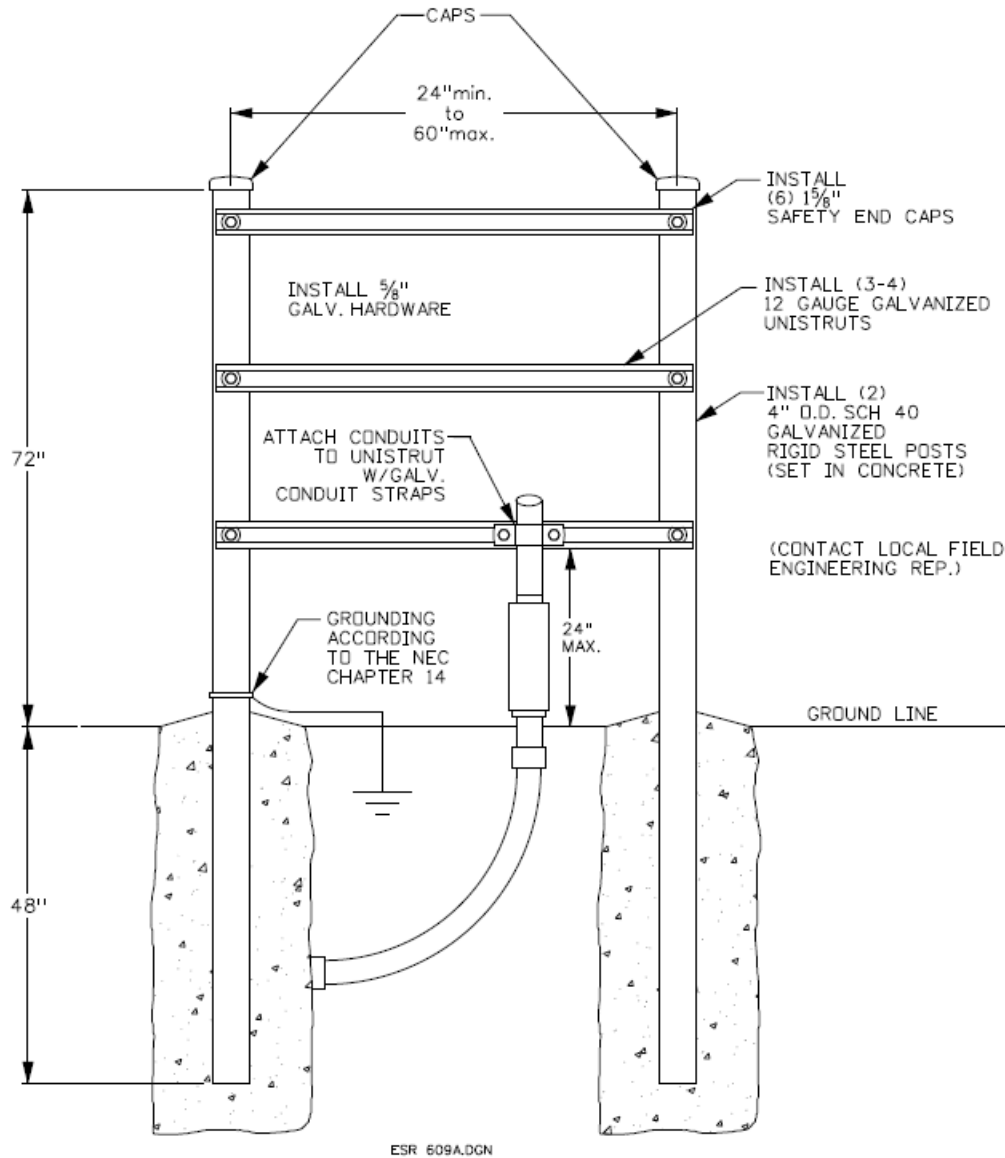

**NOTES:**

1. Steel posts are not allowed to serve as equipment grounding conductor.
2. Unistrut shall not extend beyond post & must have safety end caps for safety reasons.
3. All metallic parts shall be bonded according to the *NEC*.
4. Grounding shall conform to *NEC* and ESR Chapter 14.
5. Aluminum posts or beams are not allowed due to their corrosive properties when installed in concrete.

**609A. DEPARTMENT OF TRANSPORTATION (DOT) – RIGHT OF WAY (ROW)  
FIELD-BUILT METER STRUCTURE – ADDITIONAL REQUIREMENTS**

The following applies to outdoor free-standing field-built meter structures in DOT ROW. These rules are in addition to the rules stated in 609.

- A. Concrete base shall not extend more than 3” above finished grade, preferably flush.
- B. Base shall be constructed such that it is easily removed if necessary and small enough not to block other utility installations for using the adjacent ROW.
- C. Structures shall not be installed within intersection vision corners or other places that the DOT needs a clear area for highway operations and maintenance purposes.
- D. These structures shall not pose a roadside hazard. Any aboveground utility facility has to be located as far to the edge of ROW as possible, be out of the clear zone and if not, either be shielded or of breakaway design. If DOT has a concern with a particular placement, they may require installer to complete a roadside hazard analysis as a condition of the permit. As part of the analysis, DOT would require proof that if struck, no part of the structure would penetrate a vehicle’s windshield.
- E. No matter where the structure is placed in the ROW, the posts should be “breakaway.” DOT has details for 4” x 6” breakaway wood posts, so only those would be allowed – not 6” x 6” posts. Steel posts may not be permitted unless crash test documentation is provided and accepted by DOT.
- F. These structures look similar to small billboards, no advertising will be allowed on them. A provision will be included on any permit to indicate this; however, small warning signs or placards may be allowed if necessary to meet NESC or other state/federal safety requirements.

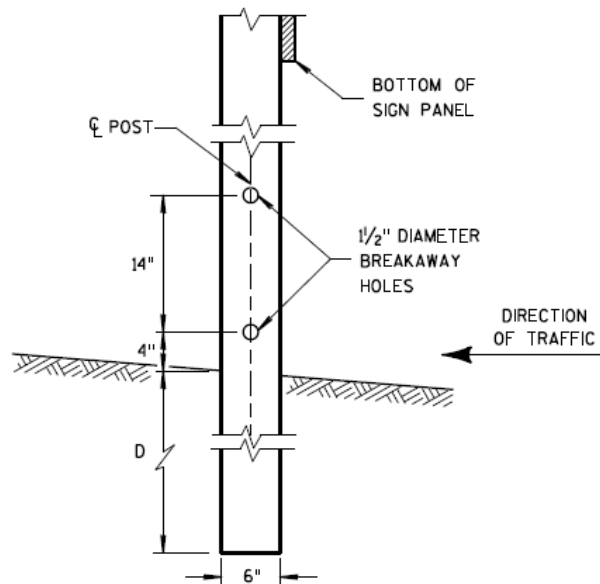

**4 "x6" WOOD POST  
MODIFICATION**



ELECTRIC SERVICE RULES

SECONDARY METERING

Issued Jan 2024

610. METER SOCKET TYPES

A. 120/240 VOLT SINGLE PHASE - OVERHEAD - SELF CONTAINED

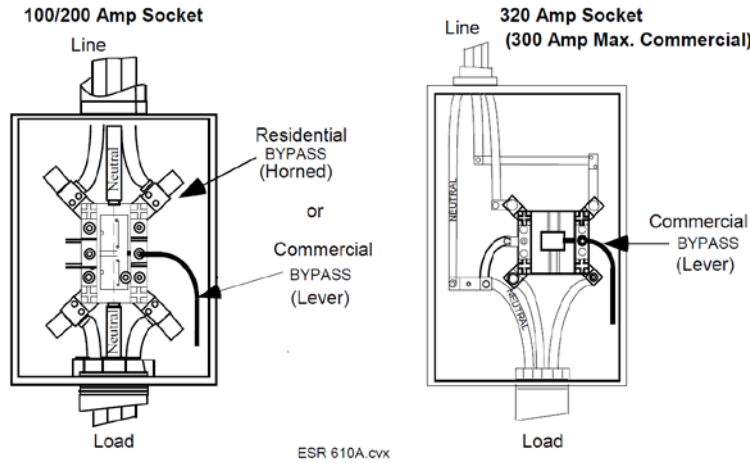

B. 120/240 VOLT SINGLE PHASE - UNDERGROUND - SELF CONTAINED

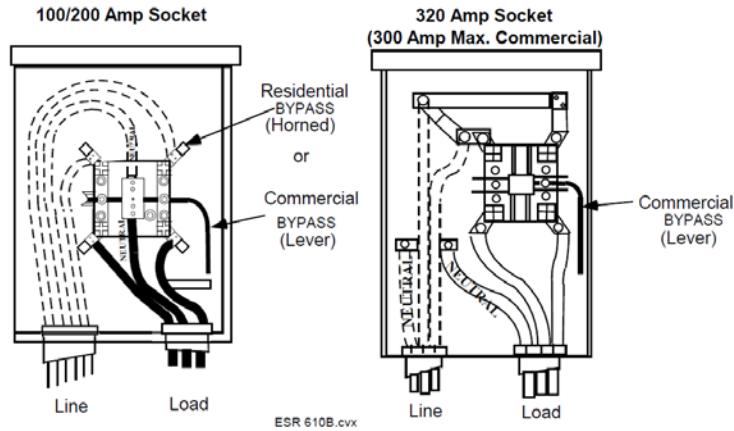

C. 120/208 VOLT SINGLE PHASE (NETWORK) - OVERHEAD - SELF CONTAINED

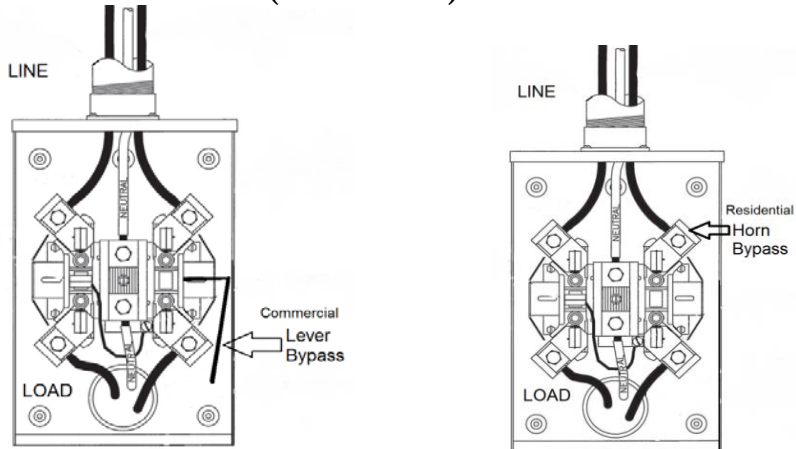

D. THREE PHASE - 4-WIRE – OVERHEAD - SELF CONTAINED

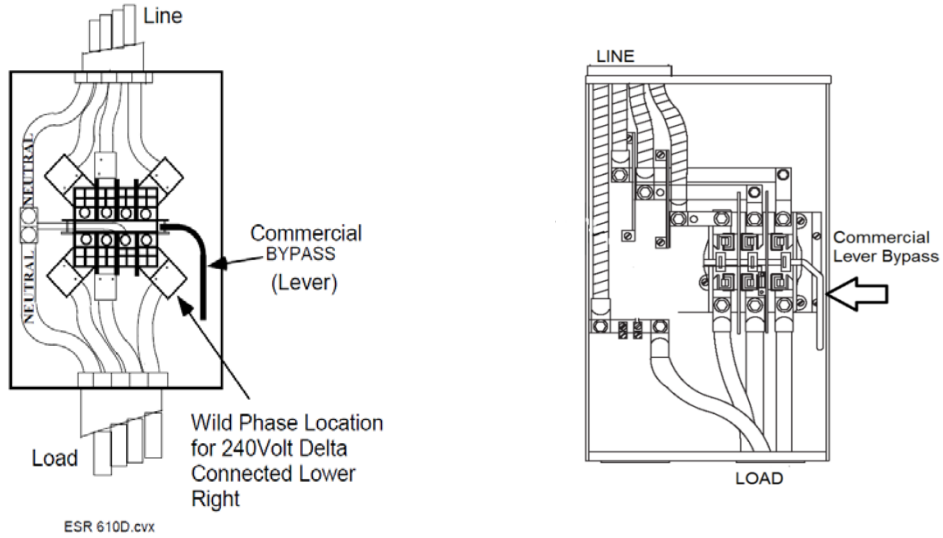

E. THREE PHASE - 4-WIRE – UNDERGROUND - SELF CONTAINED 120/208 VOLTS ONLY

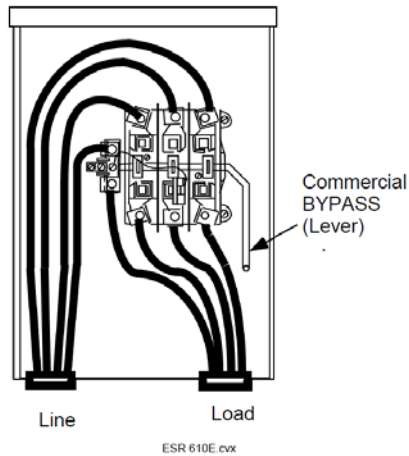

ELECTRIC SERVICE RULES

SECONDARY METERING

Issued Jan 2024

611. SELF CONTAINED GROUP & MODULAR METERING

Multiple meter positions (2 or more), up to 200 amps per socket, 250V max.

Item No.	Description	Furnished & Installed By Utility	Furnished & Installed By Customer
1	Meter	X	
2	Underground service lateral	X	
3	Multiple metering equipment		X
4	Termination area (See Note 6)		X
5	Rigid conduit		X
6	Conduit expansion joint		X
7	Concrete sleeve		X
8	Ground in accordance with the <i>NEC</i> (See ESR e-manual Chapter 14)		X

NOTES:

- Service disconnect switches shall be located adjacent to the meter or grouped in an integrated factory manufactured section of the multiple metering equipment.
- Meters shall be arranged in a logical left to right and top to bottom numbering sequence.
- The customer shall provide Alliant Energy with a diagram of the meter socket assembly with each unit clearly identified and a floor plan of the facility with each unit clearly identified.
- The normal sequence shall be **meter-switch-fuse** for six or less meters.  
 With special approval from Alliant Energy engineering and only on factory bussed equipment, a service disconnect may be installed ahead of the metering for 2 through 6-meter installations. This sequence will then be **switch-fuse-meter-switch-fuse**.  
 For 7 or more meters the sequence shall be **switch-fuse-meter-switch-fuse**.
- For units larger than 200 amps per meter position consult Alliant Energy.
- Alliant Energy will only terminate on Alliant Energy approved equipment and will not terminate on a customer's circuit breaker or disconnect switch.

**611A. SELF CONTAINED GROUP & MODULAR METERING - CONTINUED**  
 Multiple meter positions (2 or more), up to 200 amps per socket, 250V max.

**MULTIPLE METERING**  
**HORIZONTAL GROUP METERS - 2 TO 6 METERS**

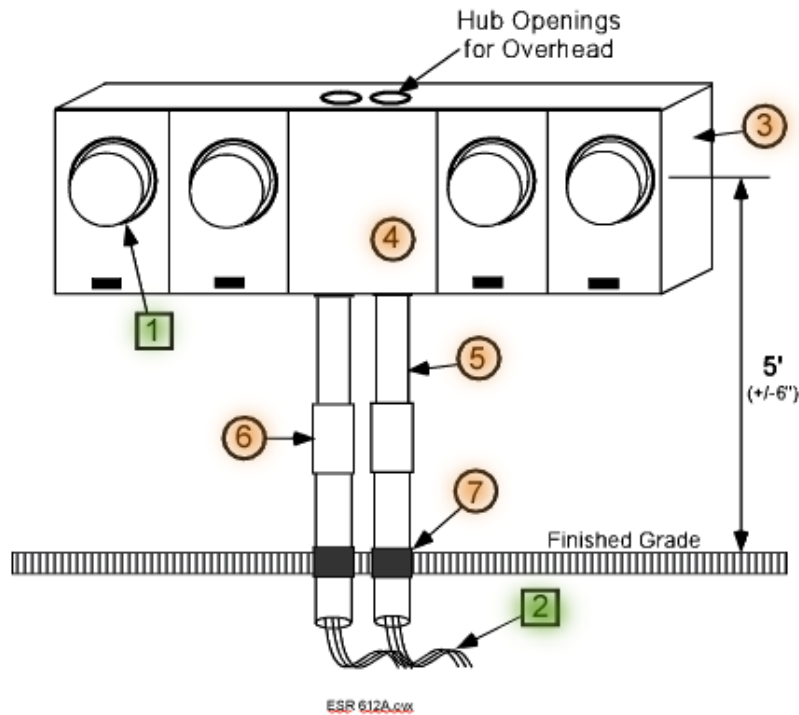

**NOTES:**

1. Refer to sections E107 & E109 of the ESE e-manual.
2. Maximum of 2 positions for 5 Terminal.
3. All customer equipment shown in this drawing must be listed in the current ESE e-manual.
4. This Group Metering unit does not require an approved Alliant Energy termination cabinet for termination of Alliant Energy conductors.

**611B. SELF CONTAINED GROUP & MODULAR METERING - CONTINUED**  
 Multiple meter positions (2 or more), up to 200 amps per socket, 250V max.

**MULTIPLE METERING**  
**METER PACK - 2 TO 6 METERS**

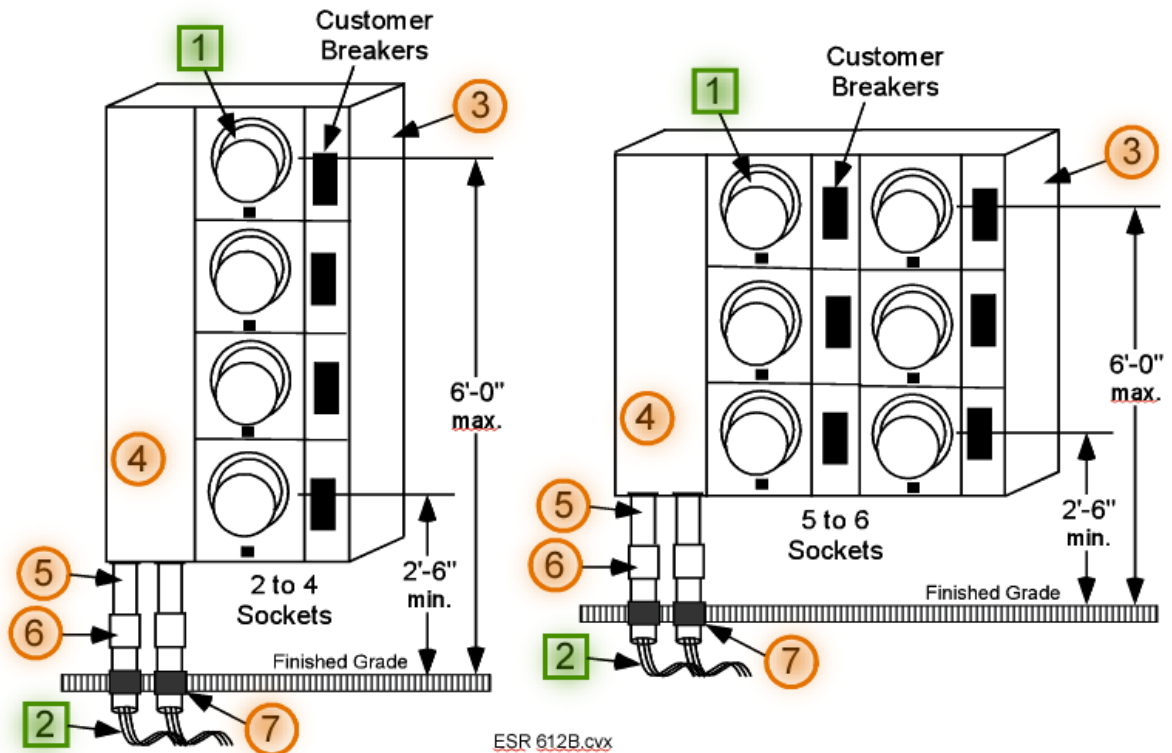

**NOTES:**

1. Refer to sections E108, E110 and E111 of the ESE e-manual.
2. All customer equipment shown in this drawing must be listed in the current ESE book.
3. Multi-meter minimum height is 2'-6" and maximum height is 6'-0".
4. This Multiple Meter Pack does not require a separate approved Alliant Energy termination cabinet for termination of Alliant Energy conductors.
5. For IA only, main disconnects shall be compliant with NEC 230.71(2020).

**611C. SELF CONTAINED GROUP & MODULAR METERING - CONTINUED**  
**Multiple meter positions (2 or more), up to 200 amps per socket, 250V max.**

**MODULAR MULTIPLE METERING**  
**HORIZONTAL BUSSED**

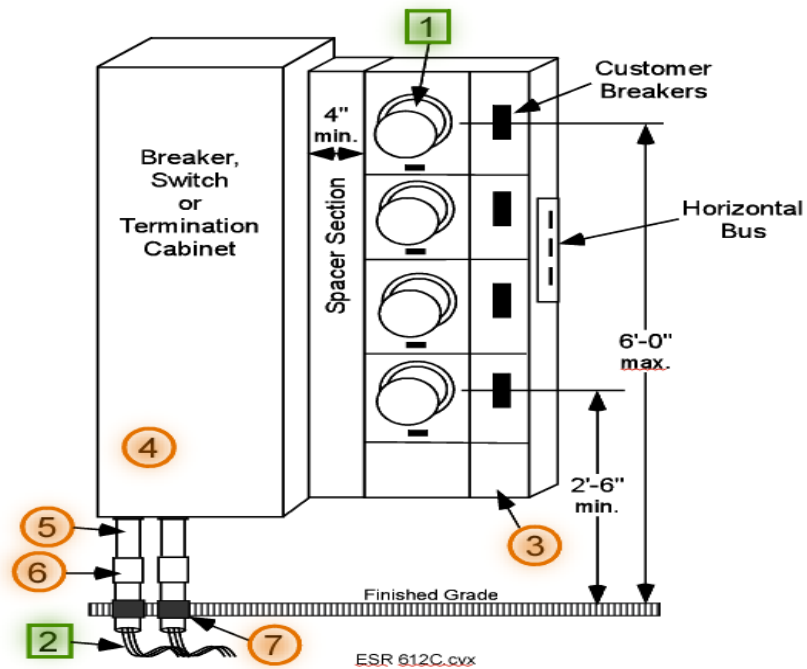

**NOTES:**

1. Refer to sections E301 and E302 of the ESE book for Bussed Meter Sockets.
2. All customer equipment shown in this drawing must be listed in the current ESE e-manual.  
 If the breaker, switch, or termination cabinet is not approved by Alliant Energy, a separate approved termination cabinet will be required. The customer will provide the conductors that terminate on the service equipment.
3. Multi-meter minimum height is 2'-6" and maximum height is 6'-0".
4. The spacer section as shown in the above drawing is required whenever the 4-inch minimum clearance from the meter glass to a cabinet cannot be obtained.
5. For IA only, main disconnects shall be compliant with NEC 230.71(2020).
6. This Modular Multiple Metering unit does require an approved Alliant Energy termination cabinet as listed in the ESE e-manual E303 - E308 for termination of Alliant Energy conductors.

611D. SELF CONTAINED GROUP & MODULAR METERING - CONTINUED

Alliant Energy Terminates in Alliant Energy Approved Termination Cabinet

Customer Extends Service Lateral Conductors to:

- Customer Termination Cabinet (Up to 6 Meters)
- Main Breaker (More Than 6 Meters)

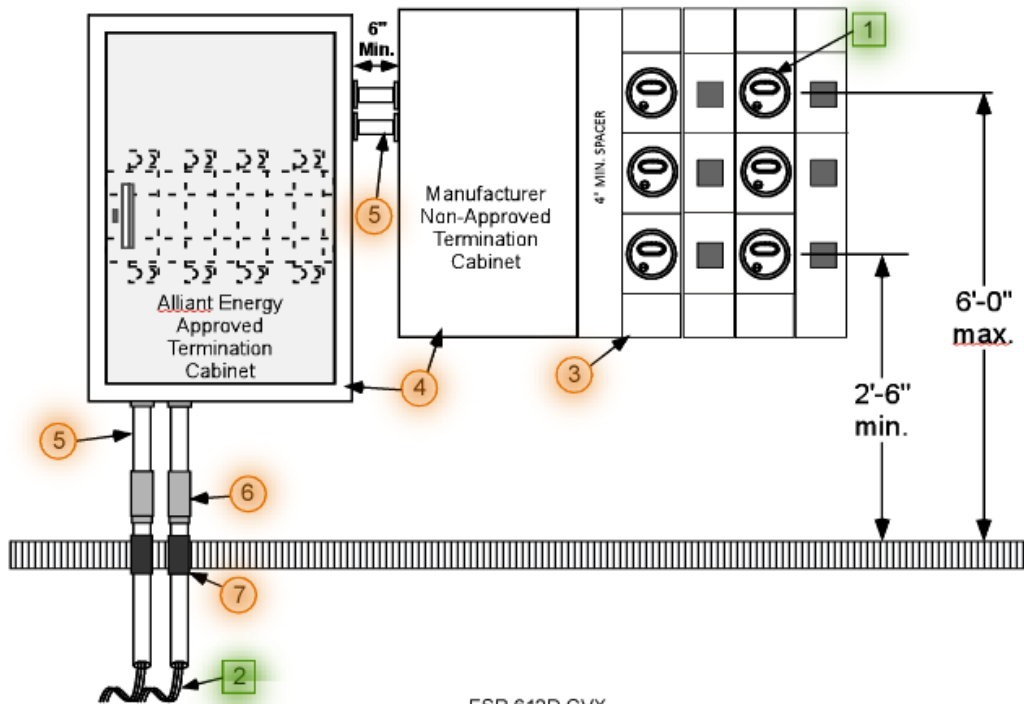

NOTES:

1. Refer to sections E301 and E302 of the ESE e-manual for Bussed Meter Sockets.
2. Multi-meter minimum height is 2'-6" and maximum height is 6'-0".
3. The spacer section as shown in the above drawing is required whenever the 4-inch minimum clearance from the meter glass to a cabinet cannot be obtained.
4. This Modular Multiple Metering unit does require an approved Alliant Energy termination cabinet as listed in the ESE e-manual E217 - E224 for termination of Alliant Energy conductors.
5. For IA only, main disconnects shall be compliant with NEC 230.71(2020).



**612. METERING TRANSFORMER CABINET INSTALLATIONS**

1. Customer should consult Alliant Energy before any installation is planned or started.
2. Working space as specified in ESR Section 606 shall be maintained for all installations.
3. Cabinet doors shall not block or impede meter socket access at any time (open or closed).

**Informational Note: This means that if a metering transformer cabinet has any internal or external cable raceway it should be designed such that the cabinet door hinge and raceway are on one side of the cabinet and then the instrument transformer rated meter socket can be mounted on the opposite side.**

4. For new services greater than 300 amps commercial, 320 amps residential and on all farm, irrigation services, metering instrument transformers (current, CTs, and/or voltage, PTs) shall be used with instrument transformer rated meters to measure power consumption.
  1. In Iowa, the customer will provide and install an instrument transformer rated meter socket. The instrument transformer rated meter socket will come with a test switch installed and wired by the factory.
  2. In Wisconsin, the customer will provide and install the instrument transformer rated meter socket. The test switch and wiring will be installed by Alliant Energy metering personnel.

NOTE: Metered and un-metered conductors shall be separated, see ESR e-manual 605.

	Utility Terminates	Customer Terminates	Customer Exit	
<b>Overhead Service (612A)</b>				
Top-In / Bottom-Out	At weather-head	Line: Top Lugs Load: Bottom Lugs	Below load-side lugs	
Top-In / Top-Out	At weather-head	Line: Top Lugs Load: Bottom Lugs	Use cabinet raceway as designed	
<b>Underground Service (612B)</b>				
Bottom-In / Top-Out	Line: Bottom Lugs	Load: Top Lugs	Above load-side lugs	
Bottom-In / Bottom-Out	Line: Bottom Lugs	Load: Top Lugs	Use cabinet raceway as designed	

**Alliant Energy approval is required from the Local Metering and Line personnel** prior to installation for the customer to obtain approval to reverse conductors (i.e., customer conductors on bottom and utilities wires on top), permanent signage (Item ID # 155910) shall note this change both inside and outside the cabinet. Any additional cost will be the responsibility of the customer.



**ELECTRIC SERVICE RULES**

**SECONDARY METERING**

**Issued Jan 2024**

**612A. OUTDOOR METERING TRANSFORMER CABINET  
OVERHEAD SERVICE (Also see Section 612 for Notes and Requirements)**

Item No.	Description	Furnished & Installed by Utility	Furnished & Installed by Customer
1	Meter	X	
2	Overhead service drop	X	
3	Metering cable (in customer provided conduit)	X	
4	Instrument transformers (inside cabinet)	X	
5	Approved meter socket (See ESE e-manual E105)		X
6	1" rigid galvanized steel (RGS) conduit		X
7	Metering transformer cabinet (See ESE e-manual E201-204, E209-212)		X
8	Service Mast - rigid galvanized steel (RGS) conduit		X
9	Service conduit(s) or trough		X

**Notes:**

1. The customer shall provide and install an Alliant Energy approved cabinet for the instrument transformers. PTs and CTs will be provided and installed by Alliant Energy. Alliant Energy approved cabinets are listed in the ESE e-manual, Chapter 2.
2. The customer shall install a 1" rigid galvanized steel (RGS) conduit for metering conductors between the metering transformer cabinet and the instrument transformer rated meter socket. Maximum allowable conduit run is 50' with two 90-degree bends. Minimum separation of 6 inches is required between the socket and the cabinet. This metering conduit shall not pass through any cabinet raceway provided for load conductors to exit the cabinet. The metering conduit shall enter the metering transformer cabinet either above or below the cabinet bus work.
3. The customer shall mount the metering transformer cabinets outdoors at the specified height above finished grade and at locations specified by Alliant Energy Engineering.
4. Alliant Energy will not terminate conductors or meter secondary services inside a customer's building.
5. Line side (un-metered) conductors shall land on the top lugs. Load side (metered) conductors shall land on the bottom lugs.

**612A. OUTDOOR METERING TRANSFORMER CABINET**

**OVERHEAD SERVICE (Also see Section 612 for Notes and Requirements)**

301 - 600 AMP – 120/240 VOLTS – SINGLE-PHASE

301 - 1200 AMP – 120/208 VOLTS – THREE-PHASE

400 - 600 AMP – 277/480 VOLTS – THREE-PHASE

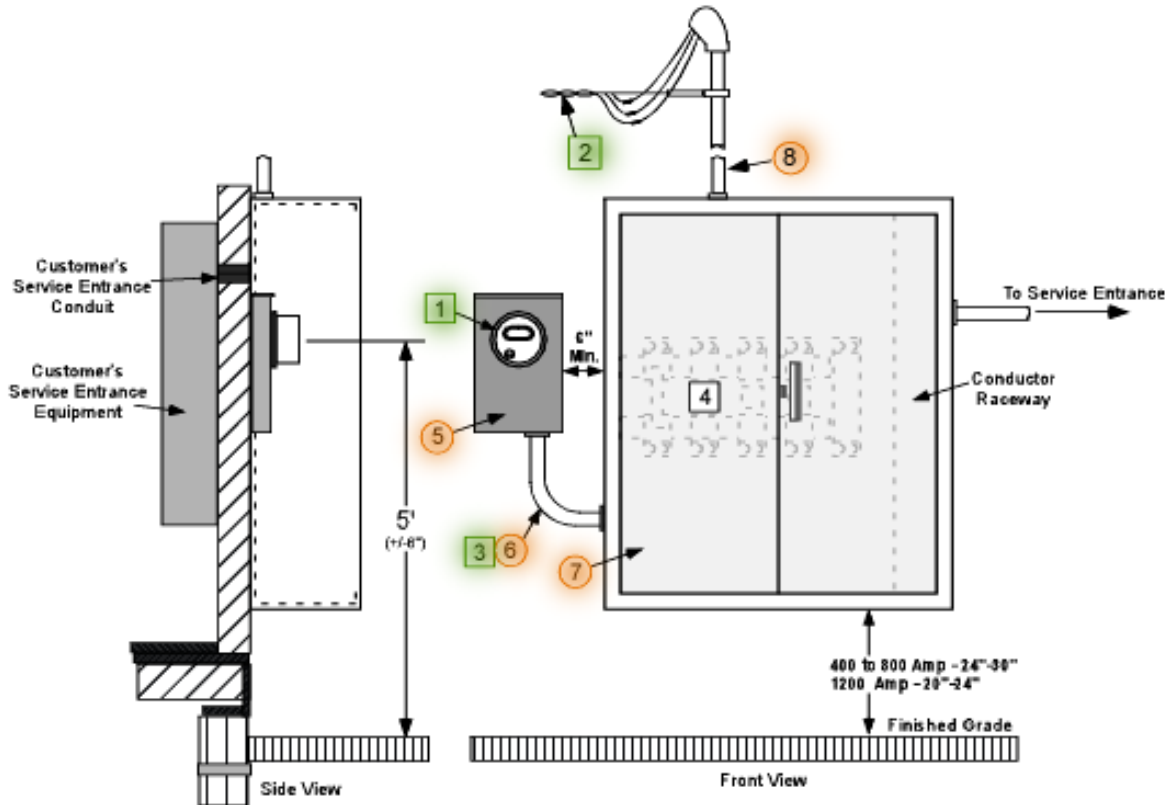

**Notes:**

1. Refer to sections E201 through E204 and E209 through E212 of the ESE e-manual for wall-mounted metering transformer cabinets for overhead services.
2. Refer to section E105 for instrument transformer rated meter sockets.

ELECTRIC SERVICE RULES

SECONDARY METERING

Issued Jan 2024

612B. OUTDOOR METERING TRANSFORMER CABINET

UNDERGROUND SERVICE (Also see Section 612 for Notes and Requirements)

Item No.	Description	Furnished & Installed by Utility	Furnished & Installed by Customer
1	Meter	X	
2	Underground service lateral	X	
3	Metering cable (in customer provided conduit)	X	
4	Instrument transformers (inside cabinet)	X	
5	Approved meter socket (See ESE E105)		X
6	1" rigid galvanized steel conduit (wall-mount only)		X
7	Metering transformer cabinet		X
8	Rigid conduit		X
9	Insulating bushing		X
10	Conduit straps (wall-mount only)		X
11	Conduit expansion joint (wall-mount only)		X
12	Sleeve/or if conduit passes through concrete or asphalt		X
13	Ground in accordance with the <i>NEC</i> (See ESR Chapter 14)		X

Notes:

1. The customer shall provide and install an Alliant Energy approved cabinet for the instrument transformers. PT's and CT's will be provided and installed by Alliant Energy. Alliant Energy approved cabinets are listed in the ESE e-manual, Chapter 2.
2. The customer shall install a 1" rigid galvanized steel (RGS) conduit for metering conductors between the metering transformer cabinet and the instrument transformer rated meter socket. Maximum allowable conduit run is 50' with two 90-degree bends. Minimum separation of 6 inches is required between the socket and the cabinet. This metering conduit shall not pass through any cabinet raceway provided for load conductors to exit the cabinet. The metering conduit shall enter the metering transformer cabinet either above or below the cabinet bus work.
3. The customer shall mount the metering transformer cabinets outdoors at the specified height above finished grade and at locations specified by Alliant Energy Engineering.
4. All free-standing (pad-mount) cabinets shall be mounted on a UL approved manufacturer's base that is a minimum of 9 inches high. If base is incorporated into the design, the bottom of the access door shall be a minimum of 9 inches above grade.
5. Alliant Energy will not terminate conductors or meter secondary services inside a customer's building.
6. Line side (un-metered) utility conductors shall land on the bottom lugs. Load side (metered) conductors shall land on the top lugs.

**612B. OUTDOOR METERING TRANSFORMER CABINET**

**UNDERGROUND SERVICE (Also see Section 612 for Notes and Requirements)**

Wall-Mount or Pad-Mount

301 - 400 AMP – 120/240 VOLTS – SINGLE-PHASE (FROM POLE XFMR)

301 - 600 AMP – 120/240 VOLTS – SINGLE-PHASE (FROM PAD XFMR)

400 AMP – 277/480 VOLTS – THREE-PHASE (FROM POLE XFMR)

Wall-Mount

301 - 400 AMP – 120/208 VOLTS – THREE-PHASE (FROM POLE XFMR)

301 - 1200 AMP – 120/208 VOLTS – THREE-PHASE (FROM PAD XFMR)

400 - 1200 AMP – 277/480 VOLTS – THREE-PHASE (FROM PAD XFMR)

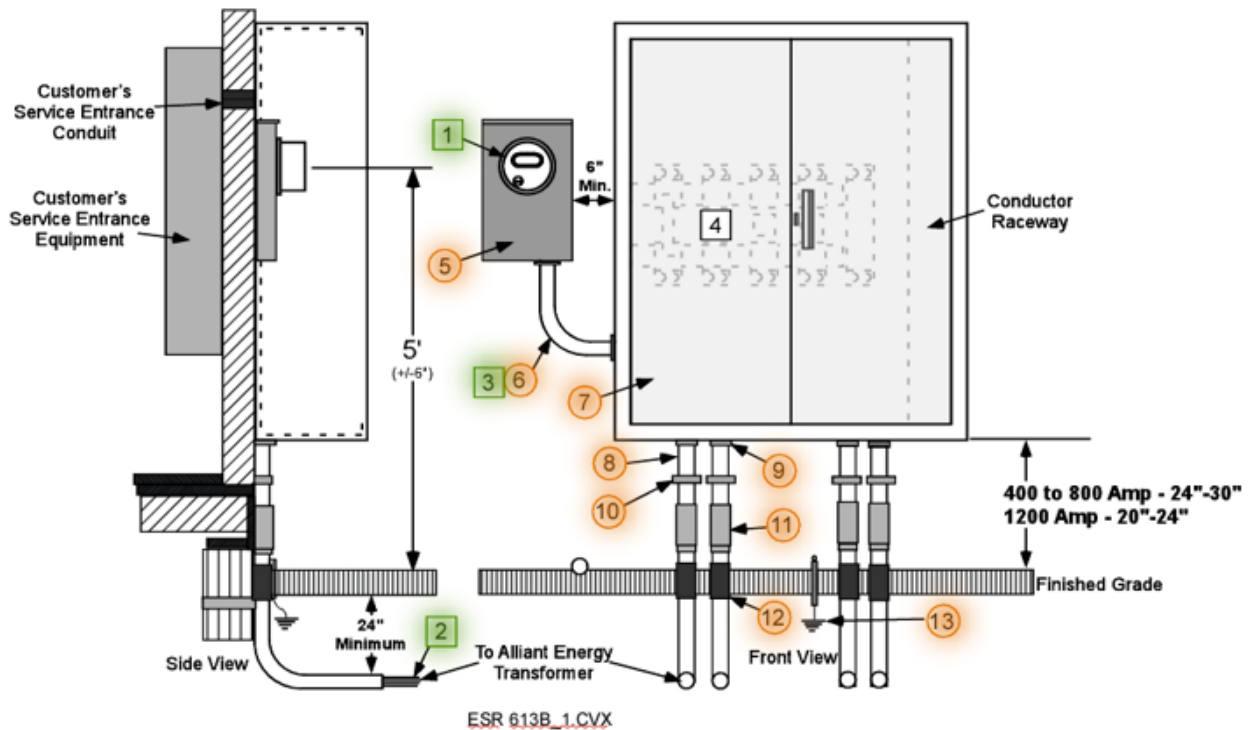

**Wall-Mount Notes:**

Refer to sections E201 through E204 and E209 through E212 of the ESE e-manual for wall-mounted metering transformer cabinets for underground services.

1. Refer to section E105 for instrument transformer rated meter sockets.
2. Cabinet height for 400 to 800 amp – 24”-30” 1200 Amp – 20”-24”

ELECTRIC SERVICE RULES

SECONDARY METERING

Issued Jan 2024

612C. OUTDOOR METERING TRANSFORMER CABINET

UNDERGROUND SERVICE (Also see Section 612 for Notes and Requirements)

Item No.	Description	Furnished & Installed by Utility	Furnished & Installed by Customer
1	Meter	X	
2	Underground service lateral	X	
3	Metering cable (in customer provided conduit)	X	
4	Instrument transformers (inside cabinet)	X	
5	Approved meter socket (See ESE E105)		X
6	1" rigid galvanized steel conduit (wall-mount only)		X
7	Metering transformer cabinet		X
8	Rigid conduit		X
9	Insulating bushing		X
10	Conduit straps (wall-mount only)		X
11	Conduit expansion joint (wall-mount only)		X
12	Sleeve/or window if conduit passes through concrete or asphalt		X
13	Ground in accordance with the <i>NEC</i> (See ESR Chapter 14)		X

Notes:

1. The customer shall provide and install an Alliant Energy approved cabinet for the instrument transformers. PT's and CT's will be provided and installed by Alliant Energy. Alliant Energy approved cabinets are listed in the ESE e-manual, Chapter 2.
2. The customer shall install a 1" rigid galvanized steel (RGS) conduit for metering conductors between the metering transformer cabinet and the instrument transformer rated meter socket. Maximum allowable conduit run is 50' with two 90-degree bends. Minimum separation of 6 inches is required between the socket and the cabinet. This metering conduit shall not pass through any cabinet raceway provided for load conductors to exit the cabinet. The metering conduit shall enter the metering transformer cabinet either above or below the cabinet bus work.
3. The customer shall mount the metering transformer cabinets outdoors at the specified height above finished grade and at locations specified by Alliant Energy Engineering.
4. All free-standing (pad-mount) cabinets shall be mounted on a UL approved manufacturer's base that is a minimum of 9 inches high. If base is incorporated into the design, the bottom of the access door shall be a minimum of 9 inches above grade.
5. Alliant Energy will not terminate conductors or meter secondary services inside a customer's building.
6. Line side (un-metered) utility conductors shall land on the bottom lugs. Load side (metered) conductors shall land on the top lugs.

**612C. OUTDOOR METERING TRANSFORMER CABINET UNDERGROUND SERVICE (Also see Section 612 for Notes and Requirements)**

Pad-Mount

301 - 3000 AMP – 120/208 VOLTS – THREE-PHASE (FROM PAD XFMR)

400 - 3000 AMP – 277/480 VOLTS – THREE-PHASE (FROM PAD XFMR)

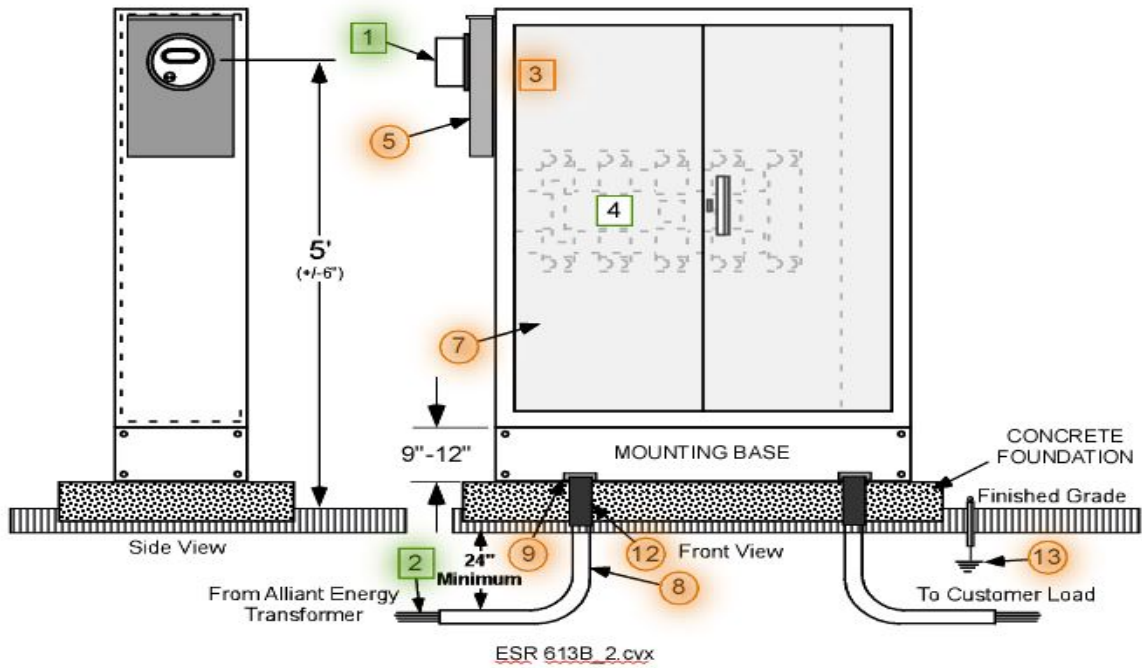

**Pad-Mount Notes:**

1. Refer to sections E201 through E216 of the ESE e-manual for pad-mounted metering transformer cabinets for underground services.
2. Refer to section E105 for instrument transformer rated meter sockets.

ELECTRIC SERVICE RULES

SECONDARY METERING

Issued Jan 2024

**613. COMBINED SELF-CONTAINED GROUP & MODULAR METERING AND METERING TRANSFORMER CABINET INSTALLATIONS**

301 - 400 AMP – 120/240 VOLTS – SINGLE-PHASE (FROM POLE XFMR)

301 - 600 AMP – 120/240 VOLTS – SINGLE-PHASE (FROM PAD XFMR)

301 - 1200 AMP – 120/208 VOLTS – THREE-PHASE (FROM POLE XFMR)

301 - 3000 AMP – 120/208 VOLTS – THREE-PHASE (FROM PAD XFMR)

400 AMP – 277/480 VOLTS – THREE-PHASE (FROM POLE XFMR)

400 - 3000 AMP – 277/480 VOLTS – THREE-PHASE (FROM PAD XFMR)

Item No.	Description	Furnished & Installed by Utility	Furnished & Installed by Customer
1	Meter	X	
2	Underground customer conductors from separate termination cabinet for bussed equipment (in customer provided conduit)	X	
3	Metering cable (in customer provided conduit)	X	
4	Instrument transformers (inside cabinet)	X	
5	Approved group metering equipment		X
6	1" rigid galvanized steel conduit (metering conduit)		X
7	Metering transformer cabinet (if required)		X
8a	Service Mast rigid galvanized steel (RGS) conduit (OH service)		X
8b	Rigid Conduit (UG service)		X
9	Conduit expansion joint (UG service)		X
10	Sleeve/or if conduit passes through concrete or asphalt (UG)		X
11	Termination Area		X
12	Service disconnect		X
13	Ground in accordance with the <i>NEC</i> (See ESR e-manual Chapter 14)		X
14	Separate Termination Cabinet required in most cases		

**NOTES:**

- Service disconnect switches shall be located adjacent to the meter or grouped in an integrated factory manufactured section of the multiple metering equipment.
- Meters shall be arranged in a logical left to right and top to bottom numbering sequence.
- The customer shall provide Alliant Energy with a diagram of the meter socket assembly with each unit clearly identified and a floor plan of the facility with each unit clearly identified.
- The normal sequence shall be **meter-switch-fuse** for 6 or less meters.  
With special approval from Alliant Energy engineering and only on factory bussed equipment, a service disconnect may be installed ahead of the metering for 2 through 6-meter installations. This sequence will then be **switch-fuse-meter-switch-fuse**.  
For 7 or more meters the sequence shall be **switch-fuse-meter-switch-fuse**.
- For units larger than 200 amps per meter position consult Alliant Energy.
- An Alliant Energy approved termination cabinet will not be required for overhead service to these types of modular metering installations.

7. For Underground service, If the termination cabinet is not approved by Alliant Energy, a separate approved termination cabinet will be required. The customer will provide the conductors that terminate on the service equipment.

**613A. COMBINED SELF-CONTAINED GROUP & MODULAR METERING AND METERING TRANSFORMER CABINET INSTALLATIONS – CONTINUED**

**Bussed Modular Metering Panels with Main Breaker/ Fused Disconnect (More than 6 Disconnects)**

- 301 - 400 AMP – 120/240 VOLTS – SINGLE-PHASE (FROM POLE XFMR)
- 301 - 600 AMP – 120/240 VOLTS – SINGLE-PHASE (FROM PAD XFMR)
- 301 - 1200 AMP – 120/208 VOLTS – THREE-PHASE (FROM POLE XFMR)
- 301 - 3000 AMP – 120/208 VOLTS – THREE-PHASE (FROM PAD XFMR)

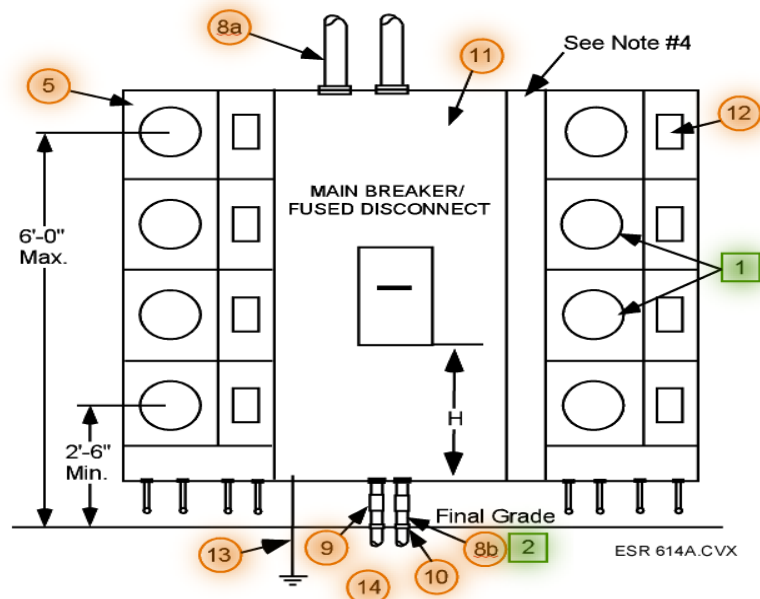

Note: Separate Approved Termination Cabinet is required in most cases.

**NOTES:**

1. Refer to Sections E301 and E302 in the ESE e-manual.
2. All customer equipment shown in this drawing must be listed in the ESE e-manual.
3. Main breaker/ Fused disconnect shall be equipped with separate landing pads with set screw or lay-in lugs for the termination of Alliant Energy service conductors. See ESE e-manual for lug sizes. If Main Disconnect Cabinet is not approved in the ESE e-manual, a separate approved termination cabinet shall be required.
4. Optional spacer section is required if meter cover is less than 4" from the side of the disconnect cabinet.



**613B. COMBINED SELF-CONTAINED GROUP & MODULAR METERING AND METERING TRANSFORMER CABINET INSTALLATIONS - CONTINUED**

**Bussed Combination Modular Metering Panel and Metering Transformer Cabinet with Termination Cabinet (2 to 6 Disconnects)**

301 - 400 AMP – 120/240 VOLTS – SINGLE-PHASE (FROM POLE XFMR)

301 - 600 AMP – 120/240 VOLTS – SINGLE-PHASE (FROM PAD XFMR)

301 - 1200 AMP – 120/208 VOLTS – THREE-PHASE (FROM POLE XFMR)

301 - 3000 AMP – 120/208 VOLTS – THREE-PHASE (FROM PAD XFMR)

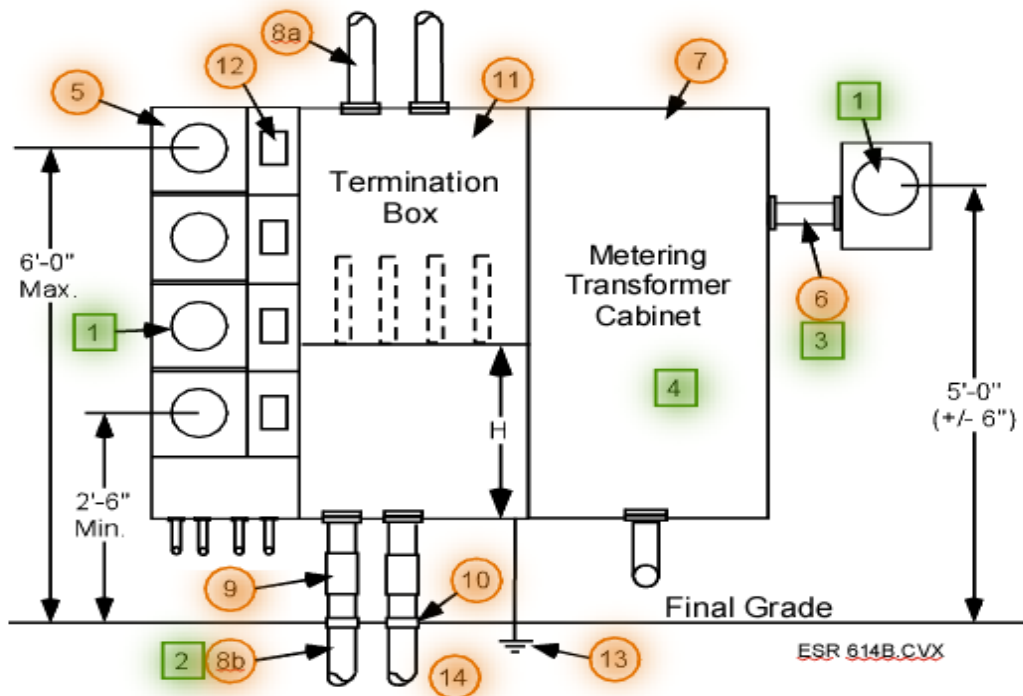

Note: Separate Approved Termination Cabinet is required in most cases

**NOTES:**

1. For Modular Metering information see sections E301 and E302 in the ESE e-manual.
2. For termination box information see sections E303B - E308B in the ESE e-manual. If termination box is not approved in the ESE e-manual, a separate approved termination box shall be required.
3. For metering transformer cabinet information see sections E303A - E308A in the ESE e-manual.
4. All customer equipment shown in this drawing must be approved and listed in the ESE e-manual.
5. For IA only, main disconnects shall be compliant with NEC 230.71(2020).

**613C. COMBINED SELF-CONTAINED GROUP & MODULAR METERING AND METERING TRANSFORMER CABINET INSTALLATIONS - CONTINUED**

**Bussed Combination Modular Metering Panel and Metering Transformer Cabinet with Main Breaker/ Fused Disconnect (More than 6 Disconnects)**

301 - 400 AMP – 120/240 VOLTS – SINGLE-PHASE (FROM POLE XFMR)

301 - 600 AMP – 120/240 VOLTS – SINGLE-PHASE (FROM PAD XFMR)

301 - 1200 AMP – 120/208 VOLTS – THREE-PHASE (FROM POLE XFMR)

301 - 3000 AMP – 120/208 VOLTS – THREE-PHASE (FROM PAD XFMR)

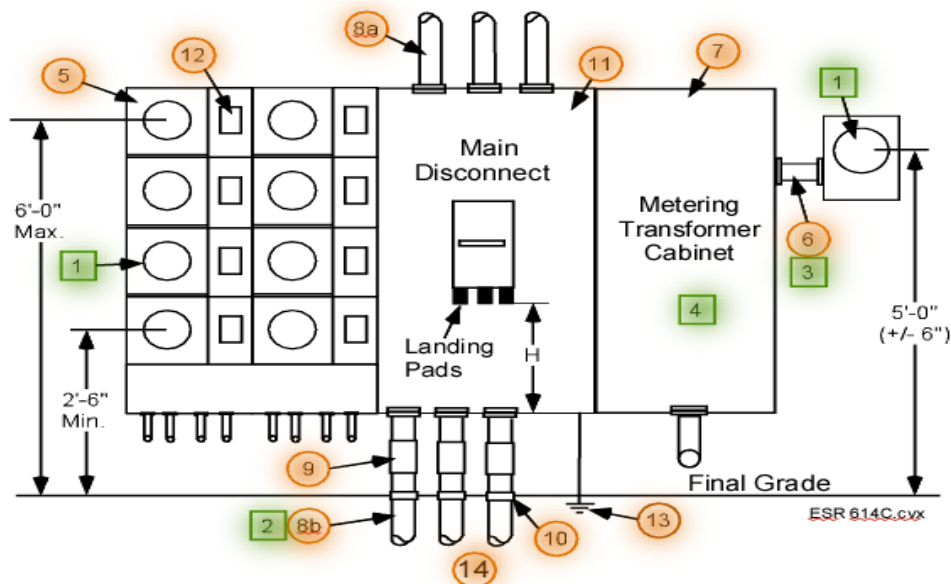

Note: Separate Approved Termination Cabinet is required in most cases.

**NOTES:**

1. For Modular Metering information see sections E301 and E302 in the ESE e-manual.
2. For metering transformer cabinet information see sections E303A - E306A in the ESE e-manual.
3. All customer equipment shown in this drawing must be listed in the ESE e-manual.
4. Main breaker disconnects must be equipped with separate landing pads with set screw or Lay-in lugs for the termination of Alliant Energy service conductors. See sections E303C - E306C in the ESE e-manual. For lug sizes see ESE E200. If Main Disconnect cabinet is not approved in ESE e-manual, a separate approved termination cabinet shall be required.

**613D. COMBINED SELF-CONTAINED GROUP & MODULAR METERING AND METERING TRANSFORMER CABINET INSTALLATIONS - CONTINUED**

**Cable in - Cable out Modular Metering Panel and Metering Transformer Cabinet with Termination Cabinet (2 to 6 Disconnects)**

301 - 400 AMP – 120/240 VOLTS – SINGLE-PHASE (FROM POLE XFMR)

301 - 600 AMP – 120/240 VOLTS – SINGLE-PHASE (FROM PAD XFMR)

301 - 1200 AMP – 120/208 VOLTS – THREE-PHASE (FROM POLE XFMR)

301 - 3000 AMP – 120/208 VOLTS – THREE-PHASE (FROM PAD XFMR)

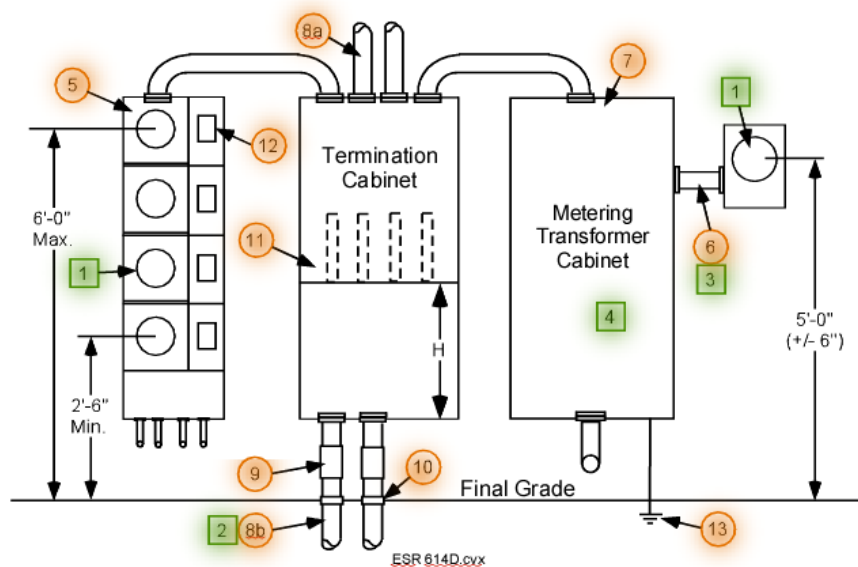

**NOTES:**

1. For Modular Metering information see sections E107 - E111 or E301 - E302 in the ESE e-manual.
2. Metering transformer cabinets with disconnects are listed in the ESE e-manual sections E209 - E216.
3. Termination cabinets without disconnects 400 amps through 3000 amps are listed in the ESE e-manual sections E217 - E224.
4. All customer equipment shown in this drawing must be listed in Alliant Energy's ESE e-manual.
5. For IA only, main disconnects shall be compliant with NEC 230.71(2020).

Alliant Energy

# Chapter 7

Electric Service Rules

**RESERVED FOR NOTES:**



## ELECTRIC SERVICE RULES

HUD MANUFACTURED HOMES

Issued Jan 2024

# CHAPTER 7

## ELECTRIC SERVICE RULES – HUD MANUFACTURED HOMES

---

### 700. SCOPE

This chapter covers service requirements for all manufactured homes constructed to the requirements of the United States Housing and Urban Development (HUD) standards and all mobile homes. The term MANUFACTURED HOME as used in this chapter shall also apply to all mobile homes (see definition of mobile home).

### 701. GENERAL REQUIREMENTS

- A. Alliant Energy will provide and install the service cable to individual or group metering points for manufactured homes. The customer will provide and install the meter socket(s) and service equipment. Manufactured homes receiving service at a central location shall obtain prior approval from Alliant Energy for each installation. Group metering installations shall follow the same rules as individually metered units.
- B. Each meter socket shall be permanently marked or tagged to coincide with the address or unit number of the location served. Appropriate marking shall consist of a permanent plaque and/or directory. A permanent marking shall also be inside each meter socket base. Meters shall not be installed until these requirements are met. [See ESR e-manual Section 603](#) for additional information.
- C. Minimum rating of a manufactured home service entrance shall be 100 amps. Receptacles shall have overcurrent protection no greater than their rated capacity.
- D. The manufactured home service entrance equipment shall contain a means for serving an accessory building, structure or additional electrical equipment located outside a manufactured home by a fixed wiring method.
- E. Manufactured home service entrance equipment is permitted to have additional receptacles for connection of electrical equipment located outside the home and all such 120-volt, single phase, 15 and 20-amp receptacles shall be protected by listed ground-fault circuit interrupter protection.
- F. All branch circuit breakers and feeder breakers shall be connected on the load side of a single service entrance breaker.
- G. A field installed manufactured home service entrance shall be located adjacent to the manufactured home and not mounted on or in the manufactured home and not more than 30 feet from the home. If the manufactured home is placed on a permanent foundation a conventional service may be installed on the foundation, if the following provisions are met:
  - 1. Service entrance rated equipment is located immediately adjacent to the meter pedestal or is an integrated part of the meter pedestal.
  - 2. The service entrance shall contain a means for serving an accessory building structure or additional electrical equipment outside the manufactured home by a fixed wiring method.
  - 3. A four-wire feeder is run from the load side of the service entrance to the electrical panel in

the manufactured home.

## 702. DEFINITIONS

**Mobile Homes: NEC 550.2,** A factory-assembled structure or structures transportable in one or more sections that are built on a permanent chassis and designed to be used as a dwelling without a permanent foundation where connected to the required utilities; these include the plumbing, heating, air-conditioning and electric systems. (The term “mobile home” refers to factory-built homes that were produced prior to June 15, 1976; when the HUD requirement went into effect)

**Manufactured Homes:** These are homes built entirely in the factory under a federal building code administered by the U.S. Department of Housing and Urban Development (HUD). The Federal Manufactured Home Construction and Safety Standards (commonly known as the HUD code) went into effect June 15, 1976. Manufactured homes may be single- or multi-section and are transported to the site and installed. The federal standards regulate manufactured housing design and construction, strength and durability, transportability, fire resistance, energy efficiency and quality. The HUD code also sets performance standards for the heating, plumbing, air-conditioning, thermal and electrical systems. It is the only federally-regulated national building code. On-site additions, such as garages, decks and porches, often add to the attractiveness of manufactured homes and must be built to local, state or regional building codes.

Manufactured homes will have a plate (sticker) located on the end of each transportable section:

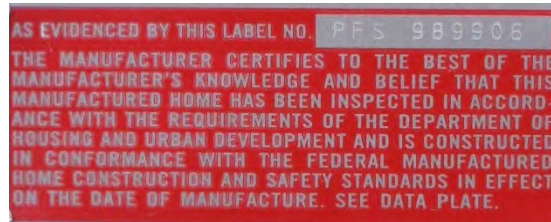

If the manufactured home is built to **NEC 550.32A** there will be a sticker located near the panel indicating that a four-wire feeder is required, these homes will be provided service according to this chapter:



## ELECTRIC SERVICE RULES

## HUD MANUFACTURED HOMES

Issued Jan 2024

If the manufactured home is built to meet the conditions of *NEC 550.32B*, the manufacturer will place a sticker on the outside of the home near the service panel indicating that grounding is required prior to connection of service, these homes will be provided service according to ESR e-manual Chapters 1 through 6:



**Modular Homes:** These factory-built homes are built to the state, local or regional code where the home will be located. Modules are transported to the site and installed. These homes will have a state sticker indicating that it has been constructed to the applicable state code requirements. ([See Section 703](#))

**Panelized Homes:** These are factory-built homes in which panels - a whole wall with windows, doors, wiring and outside siding - are transported to the site and assembled. The homes must meet state or local building codes where they are sited.

**Pre-Cut Homes:** This is the name for factory-built housing in which building materials are factory-cut to design specifications, transported to the site and assembled. Pre-cut homes include kit, log and dome homes. These homes must meet local, state or regional building codes.

**Modular homes, panelized homes and pre-cut homes will be supplied electric service according to ESR e-manual Chapters 1 through 6.**

**ELECTRIC SERVICE RULES**

**HUD MANUFACTURED HOMES**

**Issued Jan 2024**

**703. MOBILE / MANUFACTURED HOME COURTS.**

- A. A mobile/manufactured home court is defined as a contiguous parcel of land that is used for the accommodation of occupied manufactured homes. Underground distribution systems in a new court will be installed and owned by Alliant Energy according to existing extension rules and Electric Service Rules.
- B. For distribution system rebuilds, any relocation of service drops, service laterals or meter locations, requested by the customer, shall be billed according to existing extension rules.
- C. When replacing a meter socket or other equipment located at a central distribution point, the meter socket shall contain a service disconnect or a service disconnect shall be located adjacent to the meter socket. The installation shall comply with *NEC 550.32*.

**State Certification Seals**





ELECTRIC SERVICE RULES

HUD MANUFACTURED HOMES

Issued Jan 2024

**704. SERVICE ENTRANCE PEDESTAL FOR MANUFACTURED HOMES  
100-200 AMP, SINGLE-PHASE, 3-WIRE – 120/240 VOLT – UNDERGROUND**

Item No.	Description	Furnished & installed by Utility	Furnished & installed by Customer
		■	●
1	Underground service lateral	X	
2	Meter	X	
3	Mobile/manufactured home service entrance		X
4	Ground in accordance with the <i>NEC</i> (See <a href="#">ESR e-manual Chapter 14</a> )		X
5	Approved Pedestal (See <a href="#">ESE e-manual E116</a> )		X
6	Factory provided “stabilizing foot”		X
7	Mobile/manufactured home 4-wire power supply cord or permanent installed 4-wire feeder		X

**NOTES:**

1. A mobile/manufactured home service entrance pedestal or an additional disconnecting means listed as suitable for service entrance use shall be located in sight of and not more than 30’ from the exterior wall of the mobile/manufactured home it serves.
2. A clear space of 4’ shall be maintained in front of and in back of the meter pedestal.
3. Commercially made mobile/manufactured home metered service entrance pedestals shall be listed as suitable for service equipment for manufactured homes.

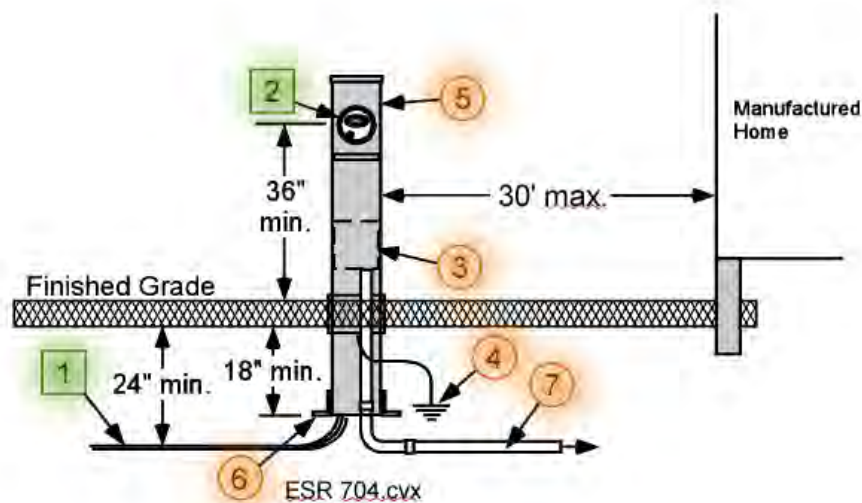



**ELECTRIC SERVICE RULES**

**HUD MANUFACTURED HOMES**

Issued Jan 2024

**705. FIELD BUILT SERVICE ENTRANCE FOR MANUFACTURED HOMES 100 - 200 AMP, SINGLE-PHASE, 3-WIRE – 120/240 VOLTS – OVERHEAD**

Item No.	Description		
		Furnished & installed by Utility	Furnished & installed by Customer
1	Overhead service drop	X	
2	Cable dead-ends(s)	X	
3	Connectors	X	
4	Meter	X	
5	Pole, treated, Class 6 Min. 5" Diameter at top, length as required to meet clearances		X
6	Guy, galvanized, stranded steel 1/4" min. and guy guard		X
7	Anchor		X
8	Ground in accordance with the <i>NEC</i> ( <a href="#">See ESR e-manual Chapter 14</a> )		X
9	Rigid Conduit or service entrance cable		X
10	Rain-tight service head		X
11	Mobile/manufactured Home service entrance equipment, rated for outdoors use single main with provisions for feeder or branch circuits		X
12	Approved meter socket ( <a href="#">See ESE e-manual E101 - E102</a> )		X
13	Either a 4-wire mobile home power supply cord or a permanently installed 4- wire feeder		X
14	Field built structure ( <a href="#">See section 613</a> )		X

**NOTES:**

1. The installation shall provide adequate clearances for Alliant Energy’s overhead service cables per NEC. Above-ground and other clearance requirements are shown in ESR e-manual Chapter 13.
2. A mobile home service entrance equipment or an additional disconnecting means listed as suitable for service entrance use shall be located in sight of and not more than 30 feet from the exterior wall of the mobile home it serves.
3. Service equipment shall be listed as (e.g. U.L.) suitable for service equipment, rated for outdoor use, power outlet type service equipment listed for mobile home or a separate meter socket, disconnect and distribution panel shall be used.

ELECTRIC SERVICE RULES

HUD MANUFACTURED HOMES

Issued Jan 2024

705. FIELD BUILT SERVICE ENTRANCE FOR MANUFACTURED HOMES 100 - 200 AMP, SINGLE-PHASE, 3-WIRE – 120/240 VOLTS – OVERHEAD – CONTINUED

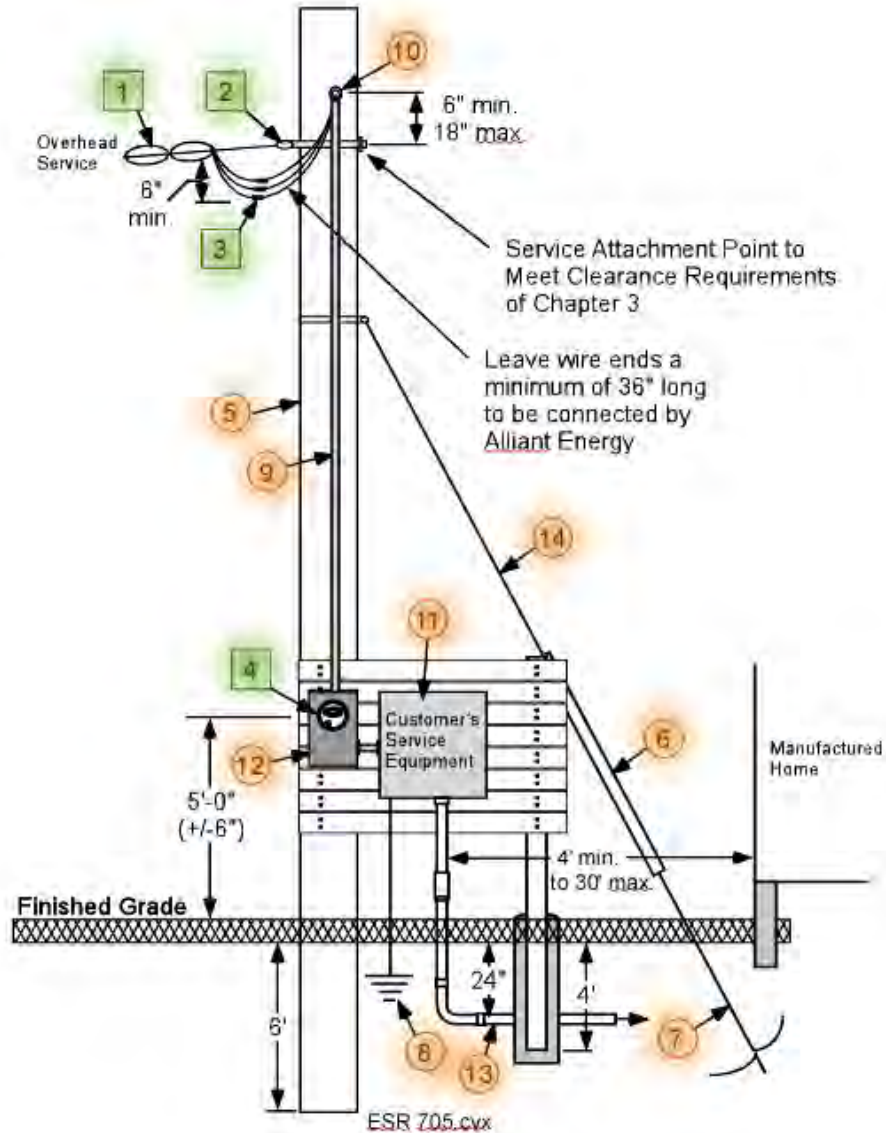

**ELECTRIC SERVICE RULES**

**HUD MANUFACTURED HOMES**

Issued Jan 2024

**706. FIELD BUILT SERVICE ENTRANCE FOR MANUFACTURED HOMES, 100 – 200 AMP, SINGLE-PHASE, 3-WIRE – 120/240 VOLTS – UNDERGROUND**

Item No.	Description	■	●
		Furnished & installed by Utility	Furnished & installed by Customer
1	Underground service lateral	X	
2	Socket type meter	X	
3	Ground in accordance with the <i>NEC</i> (ESR e-manual <a href="#">See Chapter 14</a> )		X
4	Rigid Conduit		X
5	Mobile/manufactured home service entrance equipment, rated for outdoor use, single main with provisions for feeder or branch circuits		X
6	Approved meter socket ( <a href="#">See ESE e-manual E101 - E102</a> )		X
7	Either a 4-wire manufactured home power cord or a permanently installed 4-wire feeder		X
8	Field built structure ( <a href="#">See Section 609</a> )		X
9	Expansion joint (not required if direct buried)		X

**NOTES:**

1. The free standing service entrance equipment shall contain a means for serving an accessory building or structure or additional electrical equipment located outside manufactured home by a fixed wiring method.
2. Service equipment shall be listed as (e.g. U.L.) suitable for service equipment. Power outlet type service equipment listed for manufactured home or a separate meter socket, disconnect and distribution panel shall be used.
3. Wood field built pedestals shall have a minimum of two 6” x 6” wood posts and 2” x 6” planks that are commercially treated against decay. The posts shall be buried a minimum of 4 feet deep, plumb and set in concrete the full depth. The planks shall be level and fastened with galvanized hardware. The standard width is 24 inches to 60 inches.
4. Alliant Energy Engineering approval is required for use.

ELECTRIC SERVICE RULES

HUD MANUFACTURED HOMES

Issued Jan 2024

706. FIELD BUILT SERVICE ENTRANCE FOR MANUFACTURED HOMES, 100 – 200 AMP, SINGLE-PHASE, 3-WIRE – 120/240 VOLTS – UNDERGROUND – CONTINUED

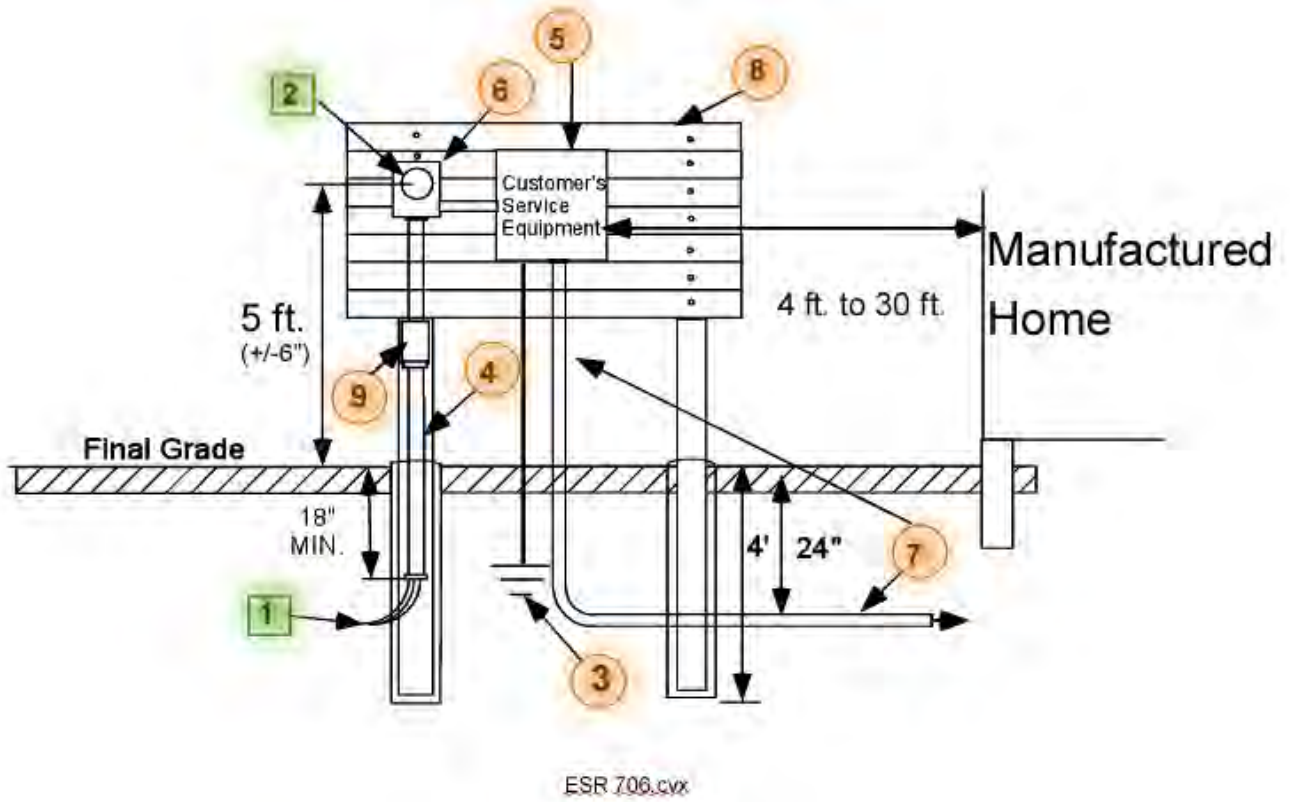

ELECTRIC SERVICE RULES

HUD MANUFACTURED HOMES

Issued Jan 2024

**707. MANUFACTURED HOME SERVICE PEDESTAL, MOUNTED ON FROST WALL PERMANENT FOUNDATION, SINGLE-PHASE, 100 – 200 AMP, 120/240 VOLTS.**

Item No.	Description	Furnished & installed by Utility	Furnished & installed by Customer
		■	●
1	Underground service lateral	X	
2	Socket type meter	X	
3	Approved meter pedestal w/main (See ESE e-manual E116)		X
4	Ground in accordance with the NEC (See ESR e-manual Chapter 14)		X
5	Mobile/manufactured home service entrance equipment, rated for outdoor use, single main with provisions for feeder or branch circuits. Can be foundation mounted or free standing		X
6	Factory installed feeder panel		X
7	Permanently install 4-wire feeder to manufactured home		X

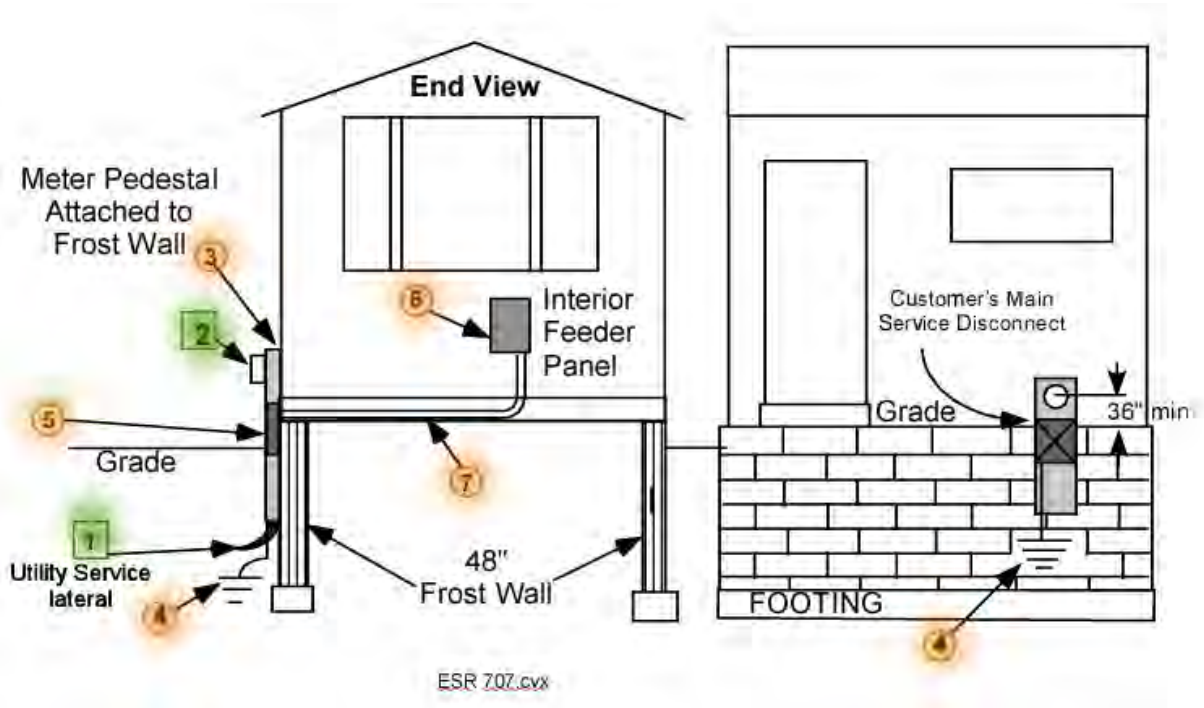



ELECTRIC SERVICE RULES

HUD MANUFACTURED HOMES

Issued Jan 2024

708. MANUFACTURED HOME SERVICE PEDESTAL, MOUNTED ON FULL BASEMENT, PERMANENT FOUNDATION, SINGLE-PHASE, 100 – 200 AMP, 120/240 VOLTS

Item No.	Description	Furnished & installed by Utility	Furnished & installed by Customer
1	Underground service lateral	X	
2	Socket type meter	X	
3	Approved meter pedestal ( <a href="#">See ESE e-manual E112</a> )		X
4	Ground in accordance with the <i>NEC</i> ( <a href="#">See ESR e-manual Chapter 14</a> )		X
5	Service entrance equipment, single main disconnect with provisions for feeder of branch circuits		X
6	Factory installed feeder panel		X
7	Permanently install 4-wire feeder to manufactured homes		X
8	Service entrance conductors		X

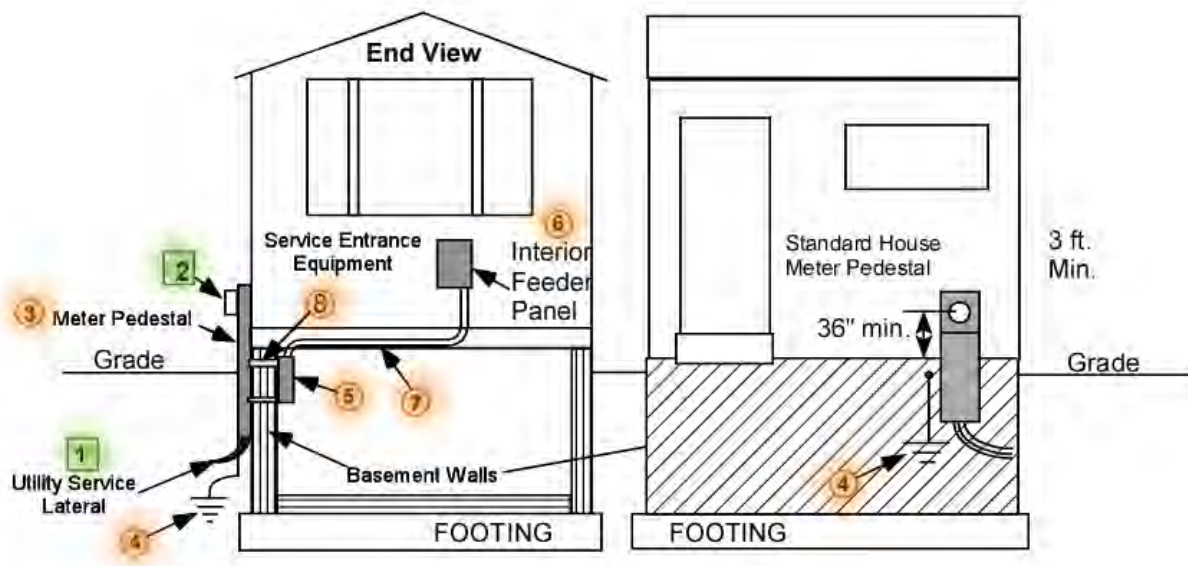

ESR 708.cvx

Alliant Energy

# Chapter 8

Electric Service Rules

**RESERVED FOR NOTES:**





## ELECTRIC SERVICE RULES

FARM SERVICES

Issued Jan 2024

# CHAPTER 8

## ELECTRIC SERVICE RULES – FARM SERVICES

---

### 800. SCOPE

This chapter includes single and three phase services to farms, farmettes / acreages where animals may be present and/or irrigation installations. The services may be provided as either overhead or underground service. The service may connect to either customer yard poles or an approved field-built structure. Alliant Energy will not install underground service laterals across rock quarries, tillable agricultural land, or other locations not suitable for underground cables and equipment. Questions regarding information in this chapter can be submitted to Agriculture compliance team by emailing: [Alliantagroup@alliantenergy.com](mailto:Alliantagroup@alliantenergy.com)

### 801. NON-FARM SERVICES

Services for installations not covered in this chapter shall be installed in accordance with services as shown in ESR e-manual Chapters 3 and 4.

### 802. FARM SERVICE YARD POLE OR STRUCTURE

- A. The farm service yard pole or field-built structure is owned by the customer. This pole or field-built structure shall be located on the customer's property. Under no circumstances may the customer's pole or field-built structure be located in road right-of-way.
- B. Alliant Energy distribution poles shall not be used as farm service yard poles, for fencing, signage, or any other non-Alliant Energy purposes.
- C. Locate the transformer a minimum of 12 feet to a maximum of 30 feet from the customer's service entrance and any other customer owned structures/facilities for potential neutral isolation requests in the future. If these distances cannot be met for farms, contact an Agriculture Compliance team member for approval.
- D. For safety concerns, the customer shall consult Alliant Energy before installing any equipment on a yard pole or field-built structure.
- E. All underground circuits extending from the yard pole or field-built structure shall be feeders or branch circuits (*NEC 547*).
- F. The customer shall protect the yard pole or field-built structure and the equipment on it from damage by vehicles and/or farm equipment. The yard pole or field-built structure and equipment on it shall be maintained in good operating condition and repaired or replaced when warranted at the customer's expense.
- G. Alliant Energy requires that all meters be installed so the meter faces an area that is accessible and clear. All meter sockets shall be securely fastened to pole or structure, plywood is not acceptable.



- H. The customer's pole top transfer switch (NEC 547.2 Site Isolation Device) shall be approved by Alliant Energy as a single switch unit mounted in one enclosure. See Electric Service Equipment e-Manual (ESE) - Chapter 3. The site isolation device shall disconnect all overhead and underground conductors on the premise from utility service.
  - I. Pole top switch installations shall have a minimum switch size of 400 Amps. A customer-owned yard pole will be used to support the customer's electrical distribution center. See special notes for pole top switch installation in ESR e-manual Section 807.
  - J. The bonding conductor from the pole top transfer switch and all grounding and grounded conductors for the customer's wiring system shall be connected together at the yard pole as shown in the grounding chapter (ESR e-manual Chapter 14).
  - K. Alliant Energy's agriculture compliance team encourages customers to convert to 3-Phase whenever practical and when appropriate for present loads or future expansion. To convert to 3-Phase a customer:
    - 1. Shall have 3-Phase loads or immediate plans to install such.
    - 2. Farm load has exceeded single-phase service sizes offered by Alliant Energy.When converting to 3-Phase, the customer shall make appropriate wiring changes on their side of the meter to utilize and balance all 3 phases as best as practical.
  - L. For animal confinement facilities and associated/connected premises, one service per farmstead applies. All exceptions shall be forwarded to Agriculture compliance team for review Please see ESR e-manual Chapter 1 for more information.
  - M. Alliant Energy will not install additional service drops or laterals to any farm building or farm structure when any portion of the building or structure is located within 150 feet of the yard pole distribution center. If another yard pole service may be warranted, the separation between the yard-poles shall be 300 feet minimum, measured in a straight line. Contact an Agriculture compliance member for more information.
  - N. A separate service may be installed to a building on the farm site if that building is not part of the farm operation. The separate service shall not originate from the yard pole.
  - O. All farm use meters shall be installed on the yard pole or field-built structure. A house (or houses) on a farm site may be considered part of the farm operation and may be metered as part of the farm service or metered separately from the yard pole or field-built structure. Meters for house services not involved with farming operations are not permitted on the yard pole and may require a separate transformer.
- Informational Note: To prevent flicker issues caused by the farm loads, customers not involved with farm operation should be served from a separate transformer provided there are no electrically conductive pathways between the two services.**
- P. Farms with two or more services on the same tract or parcel of land shall maintain a permanent plaque at each service location indicating its usage (NEC 547).

**803. KEY-INTERLOCK SYSTEMS - FARM STANDBY-GENERATION**

Keyed interlock systems for standby generation may be allowed at farm installations with prior approval from an Alliant Energy Agricultural Compliance Representative. Labeling and instructional placards shall be installed by customer as shown below.

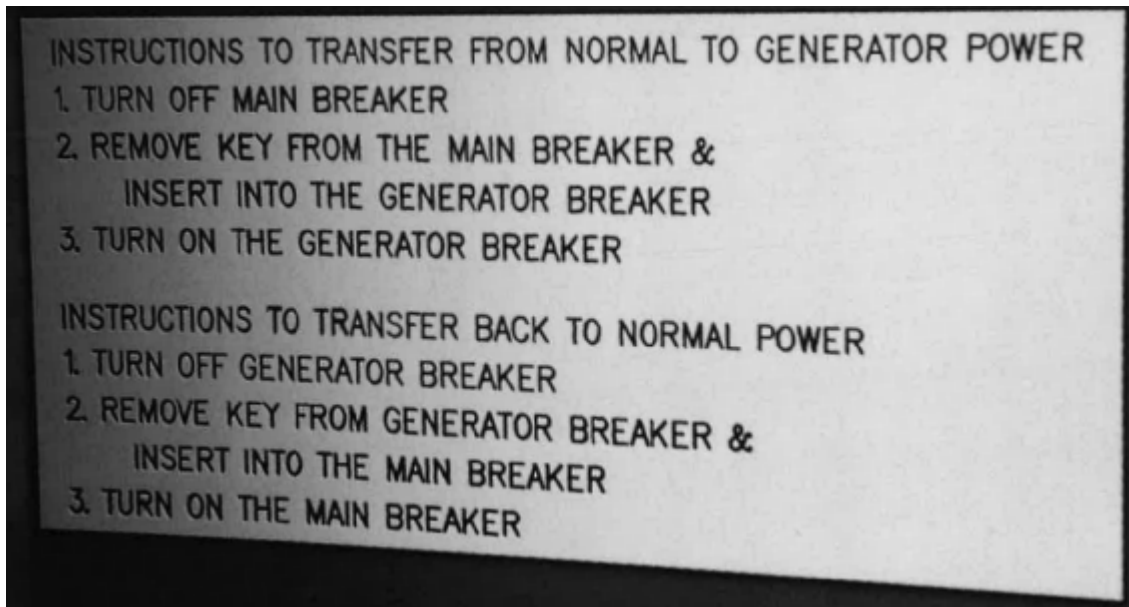
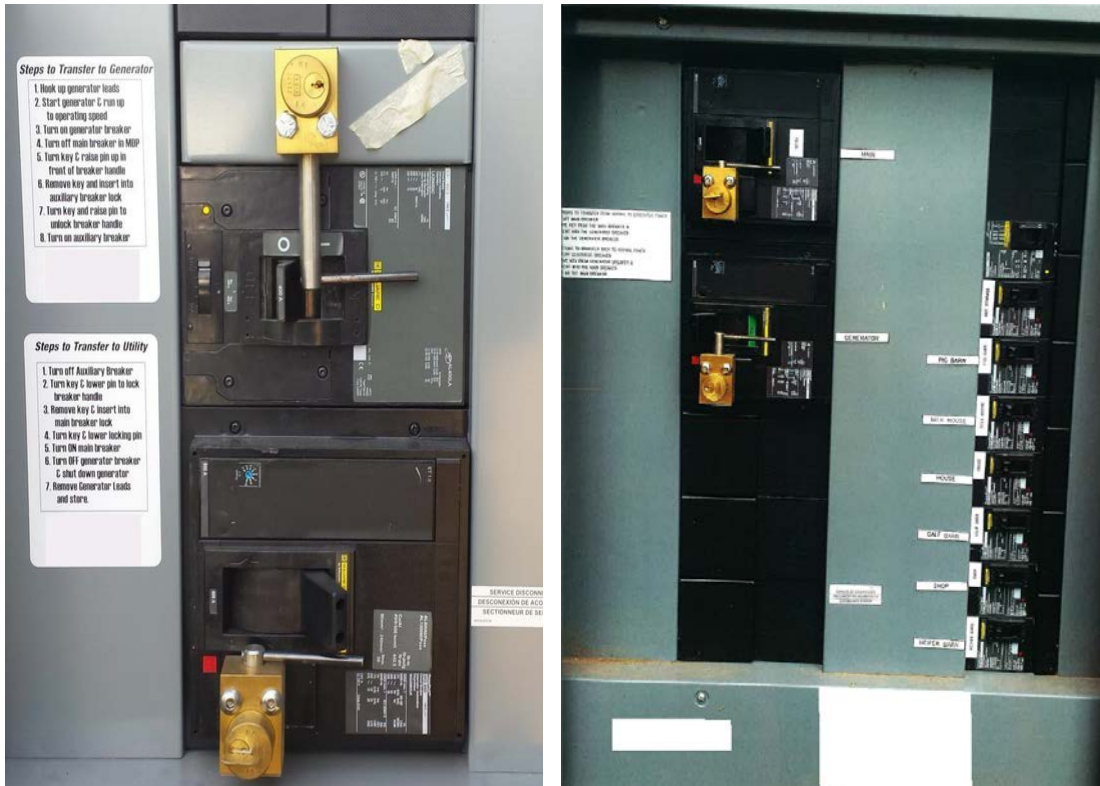

**804A. SERVICE TO A FARMYARD POLE, SELF-CONTAINED  
WITH GRADE LEVEL DISCONNECT AND OVERCURRENT PROTECTION  
300 AMP MAX AND 240 VOLT MAX**

Item No.	Description	Furnished & installed by Utility	Furnished & installed by Customer
1	Meter	X	
2 (2a)	Overhead service drop Or Underground service lateral (dashed lines)	X	
3	Service dead-end (Wisconsin: Furnished by Utility & Installed by Customer)	X (Wisconsin Only)	X (Iowa Only)
4	Pole – treated 35’ Class 5 minimum		X
5	Down guy, anchor and guy guard		X
6	Rain-tight weatherhead		X
7 (7a)	Overhead service rigid conduit Or Underground service rigid conduit with expansion joint		X
8	Approved meter socket (See ESE e-manual E103)		X
9	Service entrance / disconnect		X
10	Feeder conduit		X
11	Customer’s feeder conductors		X
12	Ground in accordance with the <i>NEC</i> (See ESR e-manual Chapter 14)		X

**NOTES:**

1. Customer shall provide 36-inch leads at the weatherhead.
2. All customer equipment shall be installed on two adjacent quadrants of the pole as shown in the pole top detail.
3. Drop shall be a minimum of 18 feet above ground at the lowest point.
4. Item 11 above is limited to six service disconnects without a main service disconnect (Item 9).
5. Item 9 may be replaced by a service rated transfer switch.
6. Sites with multiple service points require each service point to be identified per *NEC* 547.

**804A. SERVICE TO A FARMYARD POLE, SELF-CONTAINED  
WITH GRADE LEVEL DISCONNECT AND OVERCURRENT PROTECTION -  
CONTINUED  
300 AMP MAX AND 240 VOLT MAX**

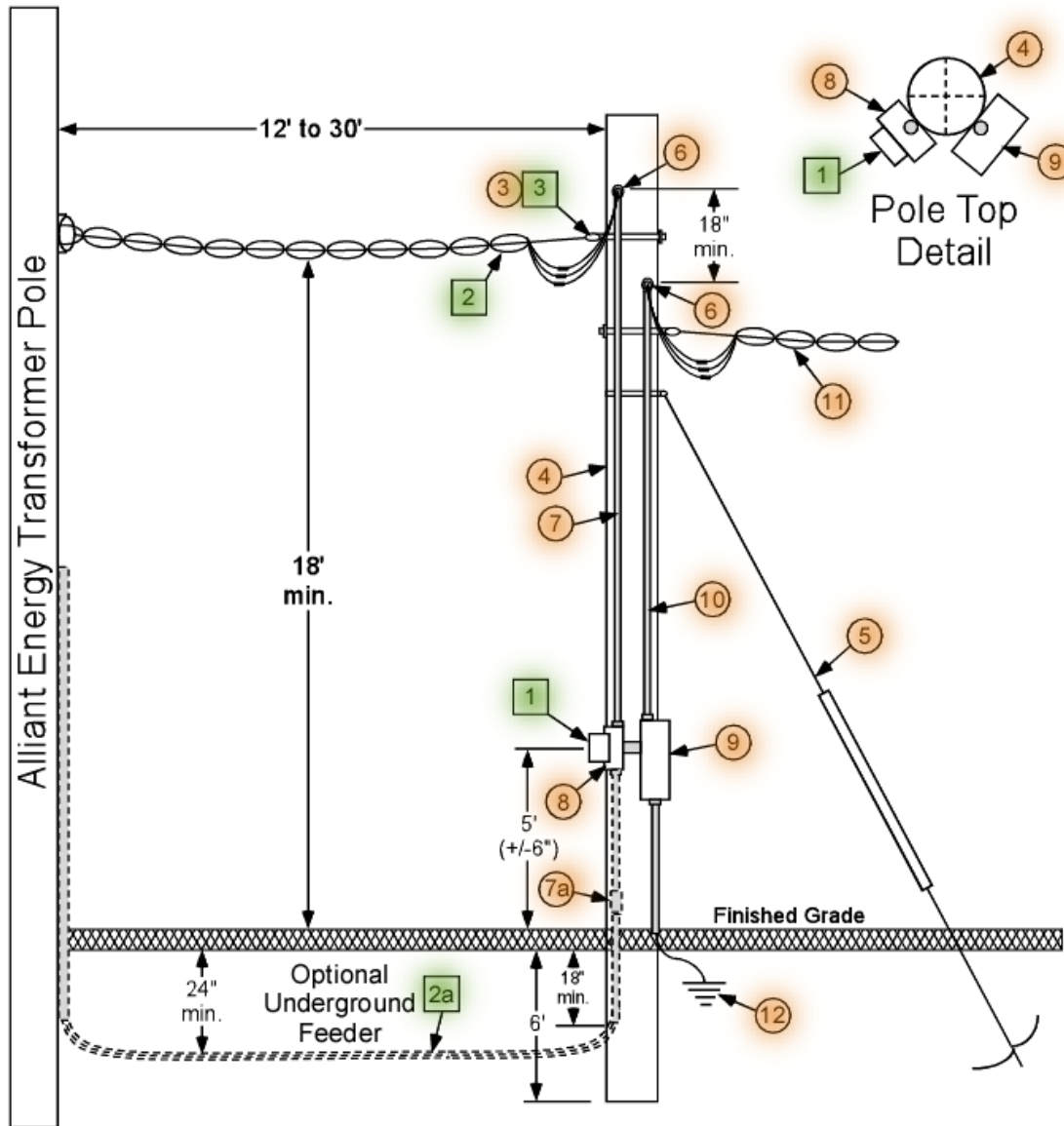

ESR 804A.cvx

**804B. SERVICE TO FIELD BUILT STRUCTURE, SELF-CONTAINED  
WITH GRADE LEVEL DISCONNECT AND OVERCURRENT PROTECTION  
300 AMP MAX AND 240 VOLT MAX**



Item No.	Description	Furnished & installed by Utility	Furnished & installed by Customer
1	Meter	X	
2 (2a)	Overhead service drop Or Underground service lateral (dashed lines)	X	
3	Service dead-end (Wisconsin: Furnished by Utility & Installed by Customer)	X (Wisconsin Only)	X (Iowa Only)
4	Pole – treated 35’ Class 5 minimum		X
5	Down guy, anchor and guy guard		X
6	Rain-tight weatherhead		X
7 (7a)	Overhead service rigid conduit Or Underground service rigid conduit with expansion joint		X
8	Field-built structure (See ESR e-manual 609)		X
9	Approved meter socket (See ESE e-manual E103)		X
10	Service entrance / disconnect		X
11	Feeder panels or branch circuits, as needed		X
12	Transfer switch, if installed		X
13	Stand-by generator circuit and outlet, if installed		X
14	Ground in accordance with the <i>NEC</i> (See ESR e-manual Chapter 14)		X

**NOTES:**

1. Customer shall provide 36-inch leads at the weatherhead.
2. Drop shall be a minimum of 18 feet above ground at the lowest point.
3. Item 11 above is limited to six service disconnects without a main service disconnect (Item 10).
4. Items 10, 11 and 12 may be replaced by a service rated disconnect/transfer switch.
5. Sites with multiple service points require each service point to be identified per *NEC* 547.

**804B. SERVICE TO FIELD BUILT STRUCTURE, SELF-CONTAINED  
WITH GRADE LEVEL DISCONNECT AND OVERCURRENT PROTECTION -  
CONTINUED**  
300 AMP MAX AND 240 VOLT MAX

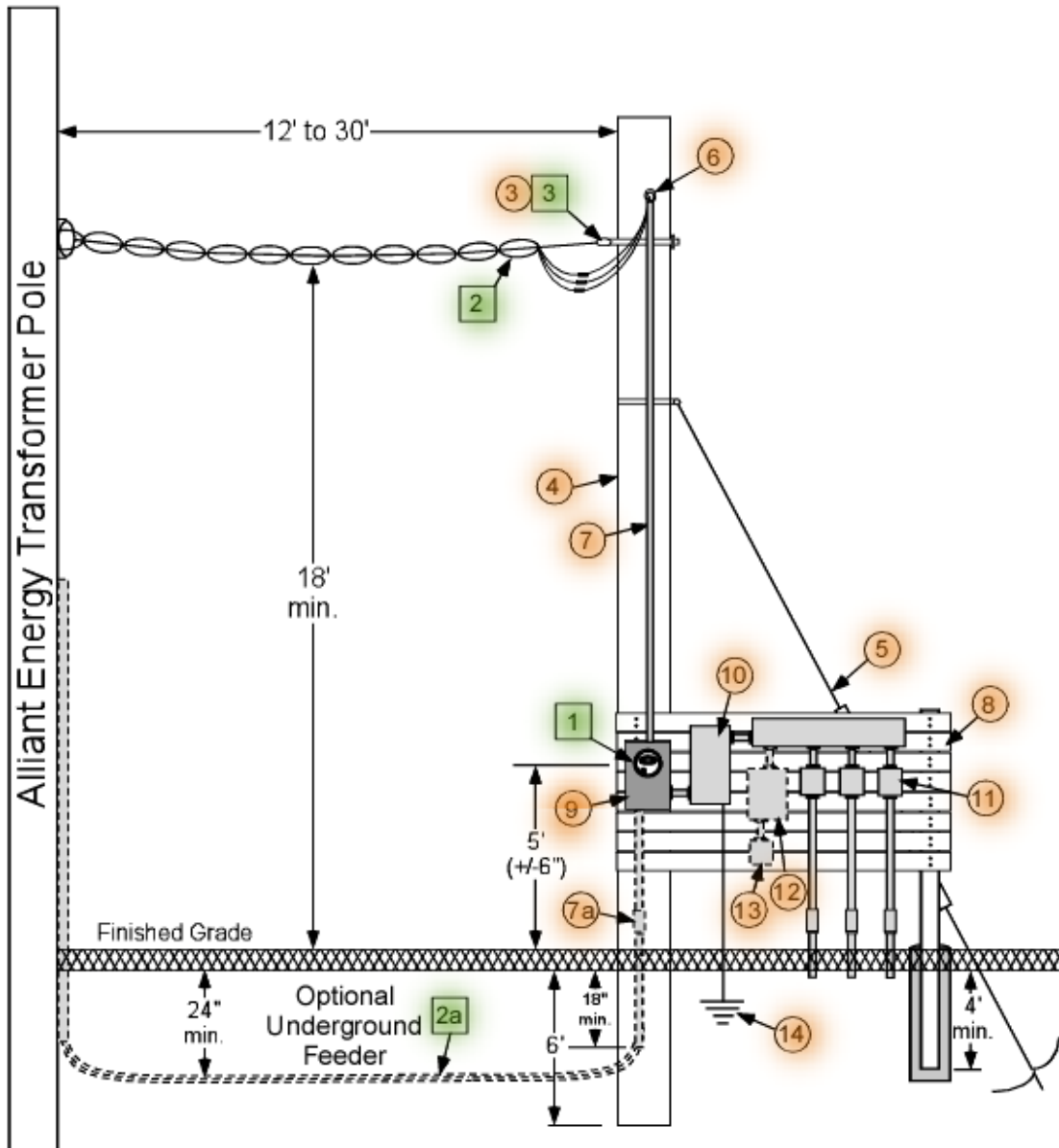

ESR 804B.cvx



**804C. UG SERVICE TO FIELD BUILT STRUCTURE, SELF-CONTAINED WITH GRADE LEVEL DISCONNECT AND OVERCURRENT PROTECTION**  
**300 AMP MAX AND 240 VOLT MAX**

Item No.	Description	Furnished & installed by Utility	Furnished & installed by Customer
1	Meter	X	
2	Underground service lateral	X	
3	Pad-mounted transformer	X	
4 (4a)	Box pad for 1 phase transformer or Box pad or concrete pad for 3 phase transformer	X	X
5	Field-built structure (See ESR e-manual 609)		X
6	Rigid conduit		X
7	Insulating bushing		X
8	Conduit expansion joint		X
9	Approved meter socket (See ESE e-manual E103)		X
10	Service entrance/disconnect		X
11	Feeder panels or branch circuits, as needed		X
12	Transfer switch, if installed		X
13	Stand-by generator circuit and outlet, if installed		X
14	Ground in accordance with the <i>NEC</i> (See ESR e-manual Chapter 14)		X

**NOTES:**

1. A clear space of 10 feet shall be provided in front of the transformer.
2. Customer shall install secondary rigid conduit into the transformer (See ESR e-manual Section 407).
3. Item 11 above is limited to six service disconnects without a main service disconnect (Item 10).
4. Items 10, 11 and 12 may be replaced by a service rated disconnect/transfer switch.
5. Sites with multiple service points require each service point to be identified per *NEC* 547.

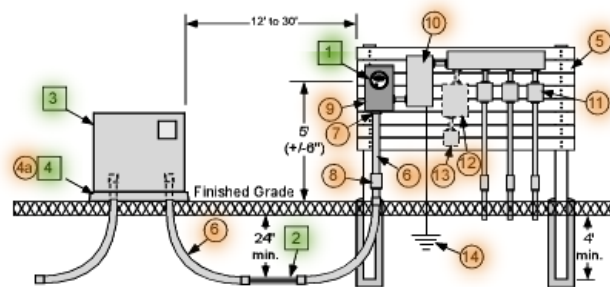

ESR 804C.svg



ELECTRIC SERVICE RULES

FARM SERVICES

Issued Jan 2024

**805. UG SERVICE TO FIELD BUILT STRUCTURE, FROM PAD-MOUNT TRANSFORMER AND METERING TRANSFORMER CABINET**  
301 - 3000 AMPS

Item No.	Description	Furnished & installed by Utility	Furnished & installed by Customer
1	Meter	X	
2	Underground service lateral	X	
3	Pad-mounted transformer	X	
4 (4a)	Box pad for 1 phase transformer or Box pad or concrete pad for 3 phase transformer	X	X
5	Field-built structure (See ESR e-manual 609)		X
6	Rigid conduit		X
7	Pad-mounted metering transformer cabinet (See ESE e-manual E201-E208)		X
8	Conduit expansion joint		X
9	Approved meter socket (See ESE e-manual E105)		X
10	Termination cabinet or Service entrance/disconnect		X
11	Feeder panels or branch circuits, as needed		X
12	Transfer switch, if installed		X
13	Stand-by generator circuit and outlet, if installed		X
14	Ground in accordance with the <i>NEC</i> (See ESR e-manual Chapter 14)		X

**NOTES:**

1. A clear space of 10 feet shall be provided in front of the transformer.
2. Customer shall install secondary rigid conduit into the transformer (See ESR e-manual Section 407).
3. Item 11 above is limited to six service disconnects without a main service disconnect (Item 10).
4. Items 10, 11 and 12 may be replaced by a service rated disconnect/transfer switch.
5. Sites with multiple service points require each service point to be identified per *NEC* 547.9
6. Any instrument metered service may utilize pad-mount metering equipment, cabinets larger than 1200 amps shall not be mounted on field-built structures.
7. Livestock farms must have at least 8' of separation between transformer concrete pad and metering transformer cabinet concrete pad.

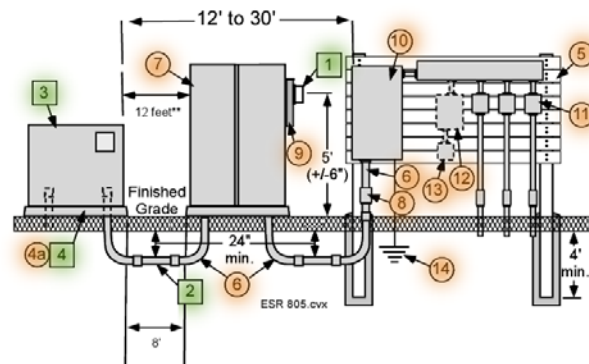



**806A. OVERHEAD SERVICE TO A FIELD BUILT STRUCTURE, W/GRADE LEVEL DISCONNECT AND METERING TRANSFORMER CABINET FOR FARM OR IRRIGATION**

301 - 600<sup>(3)</sup> AMP - SINGLE PHASE - 120/240 VOLT

301 - 1200<sup>(4)</sup> AMP - THREE PHASE - 120/208 VOLT

100 - 600<sup>(3)</sup> AMP - THREE PHASE - 277/480 VOLT



Item No.	Description	Furnished & installed by Utility	Furnished & installed by Customer
1	Meter	X	
2	Overhead service drop	X	
3	Current transformers and potential transformers	X	
4	Service dead-end (Wisconsin: Furnished by Utility & Installed by Customer)	X (Wisconsin Only)	X (Iowa Only)
5	Pole - treated 35' Class 5 minimum		X
6	Down guy, anchor, guy guard		X
7	Rain-tight weatherhead		X
8	Overhead service rigid conduit		X
9	Field-built structure (See ESR e-manual 609)		X
10	Approved meter socket (See ESE e-manual E105)		X
11	Metering transformer cabinet (See ESE e-manual E201 - E208)		X
12	Service entrance/disconnect		X
13	Feeder panels or branch circuits, as needed		X
14	Transfer switch, if installed		X
15	Stand-by generator circuit and outlet, if installed		X
16	Ground in accordance with the <i>NEC</i> (See ESR e-manual Chapter 14)		X

**NOTES:**

- Alliant Energy will install an overhead service drop in accordance with Alliant Energy's applicable rates and extension rules.
- If large equipment is to be driven under the service drop, reference NESC. Drop shall be a minimum of 18 feet above ground at the lowest point.
- 600 Amp Continuous Duty or 800 Amp Intermittent Duty Service Equipment.
- Field-built structure design is limited to a 1200 Amp max cabinet. For larger services, see ESR e-manual section 805, pad-mount CT cabinets.
- Item 13 above is limited to six service disconnects without a main service disconnect (Item 12).
- Items 12, 13 and 14 may be replaced by a service rated disconnect/transfer switch.
- Sites with multiple service points require each service point to be identified per *NEC* 547.

**806A. OVERHEAD SERVICE TO A FIELD BUILT STRUCTURE, W/GRADE LEVEL DISCONNECT AND METERING TRANSFORMER CABINET FOR FARM OR IRRIGATION - CONTINUED**

- 301 - 600<sup>(3)</sup> AMP - SINGLE PHASE - 120/240 VOLT
- 301 - 1200<sup>(4)</sup> AMP - THREE PHASE - 120/208 VOLT
- 100 - 600<sup>(3)</sup> AMP - THREE PHASE - 277/480 VOLT

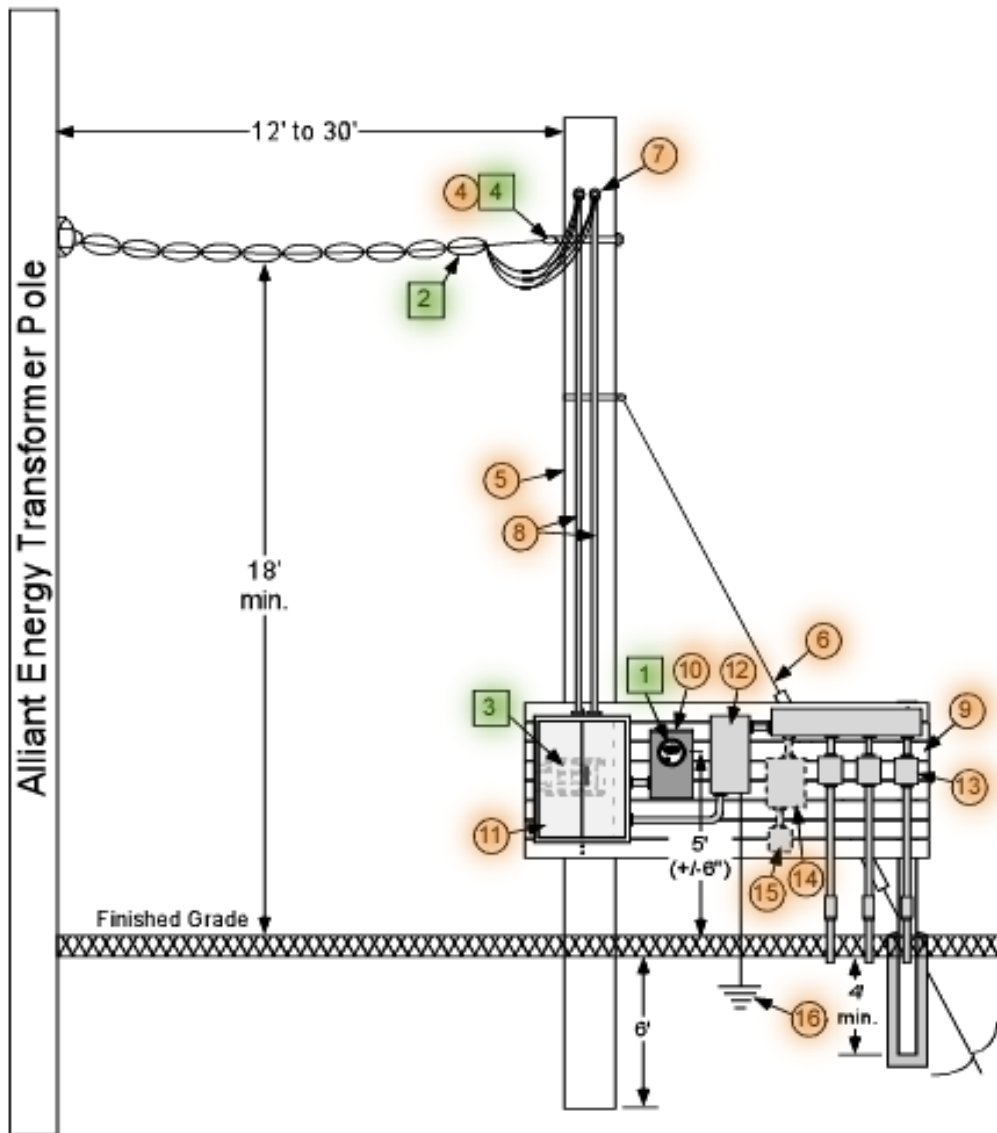

ESR 806A.cvx

**806B. UNDERGROUND SERVICE TO A FIELD BUILT STRUCTURE, W/GRADE LEVEL DISCONNECT AND METERING TRANSFORMER CABINET FOR FARM OR IRRIGATION**

301 - 400<sup>(3)</sup> AMP - 120/240 VOLTS - SINGLE-PHASE (FROM POLE XFMR)

100 - 400 AMP - 120/208V & 277/480 VOLTS - THREE-PHASE (FROM POLE XFMR)

Item No.	Description	Furnished & installed by Utility	Furnished & installed by Customer
		■	●
1	Meter	X	
2	Underground service lateral	X	
3	Current transformers and potential transformers	X	
4	Rigid conduit		X
5	Insulating bushing		X
6	Conduit expansion joint		X
7	Field-built structure (See ESR e-manual 609)		X
8	Approved meter socket (See ESE e-manual E105)		X
9	Metering transformer cabinet (See ESE e-manual E201 - E208)		X
10	Service entrance/disconnect		X
11	Feeder panels or branch circuits, as needed		X
12	Transfer switch, if installed		X
13	Stand-by generator circuit and outlet, if installed		X
14	Ground in accordance with the <i>NEC</i> (See ESR e-manual Chapter 14)		X

**NOTES:**

1. Alliant Energy will install an overhead service drop in accordance with Alliant Energy’s applicable rates and extension rules.
2. If large equipment is to be driven under the service drop, reference NESC. Drop shall be a minimum of 18 feet above ground at the lowest point.
3. 600 Amp may be allowed with engineering approval in areas where access is designated as aerial lift access only. Limited by capacity of maximum of parallel 350 MCM AL risers, the ampacity is limited to 400 Amp by the cable riser capacity where there is not aerial lift access.
4. Field-built structure design is limited to a 1200 Amp max cabinet. For larger services, see ESR e-manual section 805, pad-mount metering transformer cabinets.
5. Item 11 is limited to six service disconnects without a main service disconnect (Item 10).
6. Items 12, 13 and 14 may be replaced by a service rated disconnect/transfer switch.
7. Sites with multiple service points require each service point to be identified per *NEC* 547.

**806B. UNDERGROUND SERVICE TO A FIELD BUILT STRUCTURE,  
W/ GRADE LEVEL DISCONNECT AND METERING TRANSFORMER  
CABINET FOR FARM OR IRRIGATION - CONTINUED**

301 - 400<sup>(3)</sup> AMP - 120/240 VOLTS - SINGLE-PHASE (FROM POLE XFMR)

100 - 400 AMP - 120/208V & 277/480 VOLTS - THREE-PHASE (FROM POLE XFMR)

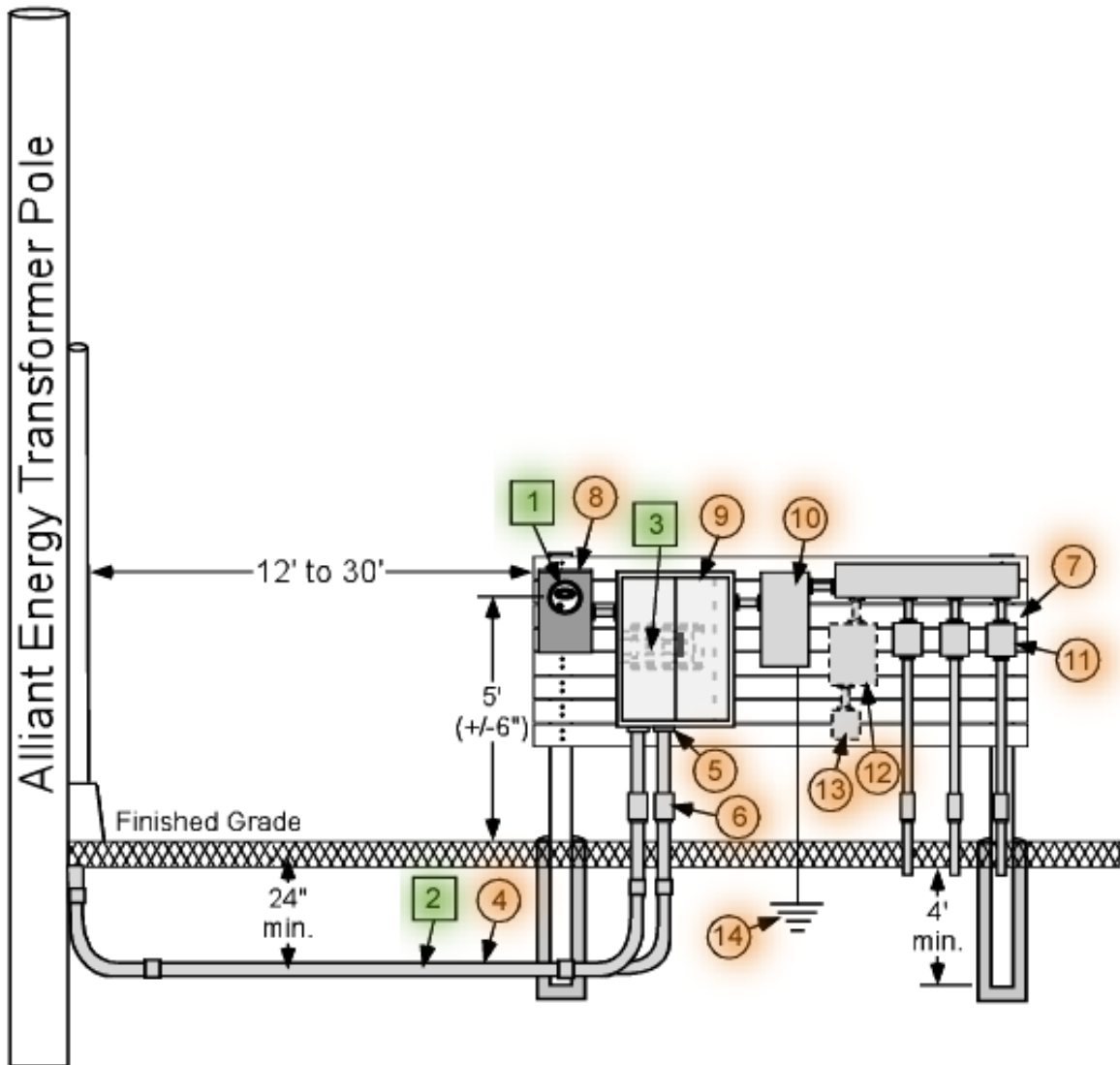

ESR 806B.cvx

**806C. UNDERGROUND SERVICE TO A FIELD BUILT STRUCTURE, W/GRADE LEVEL DISCONNECT AND METERING TRANSFORMER CABINET FOR FARM OR IRRIGATION**

301 - 600<sup>(3)</sup> AMP - 120/240 VOLTS - SINGLE-PHASE (FROM PAD XFMR)

301 - 1200<sup>(4)</sup> AMP - 120/208 VOLTS -THREE-PHASE (FROM PAD XFMR)

100 - 1200<sup>(4)</sup> AMP - 277/480 VOLTS - THREE-PHASE (FROM PAD XFMR)

Item No.	Description	Furnished & installed by Utility	Furnished & installed by Customer
1	Meter	X	
2	Underground service lateral	X	
3	Current transformers and potential transformers	X	
4	Pad-mounted transformer	X	
5 (5a)	Box pad for 1 phase transformer or Box pad or concrete pad for 3 phase transformer	X	X
6	Rigid conduit		X
7	Insulating bushing		X
8	Conduit expansion joint		X
9	Field-built structure (ESR e-manual 609)		X
10	Approved meter socket (See ESE e-manual E105)		X
11	Metering transformer cabinet (See ESE e-manual E201 - E208)		X
12	Service entrance/disconnect		X
13	Feeder panels or branch circuits, as needed		X
14	Transfer switch, if installed		X
15	Stand-by generator circuit and outlet, if installed		X
16	Ground in accordance with the <i>NEC</i> (See ESR e-manual Chapter 14)		X

**NOTES:**

1. A clear space of 10 feet shall be provided in front of the transformer.
2. Customer to install primary conduit into the transformer (See ESR e-manual section 407).
3. 600 Amp Continuous Duty or 800 Amp Intermittent Duty Service Equipment.
4. Field-built structure design is limited to a 1200 Amp max cabinet. For larger services, see ESR e-manual section 805, pad-mount metering transformer cabinets.
5. Item 13 above is limited to six service disconnects without a main service disconnect (Item 12).
6. Items 12, 13 and 14 may be replaced by a service rated disconnect/ service rated transfer switch.
7. Sites with multiple service points require each service point to be identified per *NEC* 547.

**806C. UNDERGROUND SERVICE TO A FIELD BUILT STRUCTURE, W/ GRADE LEVEL DISCONNECT AND METERING TRANSFORMER CABINET FOR FARM OR IRRIGATION - CONTINUED**

- 301 - 600<sup>(3)</sup> AMP - 120/240 VOLTS - SINGLE-PHASE (FROM PAD XFMR)
- 301 - 1200<sup>(4)</sup> AMP - 120/208 VOLTS - THREE-PHASE (FROM PAD XFMR)
- 100 - 1200<sup>(4)</sup> AMP - 277/480 VOLTS - THREE-PHASE (FROM PAD XFMR)

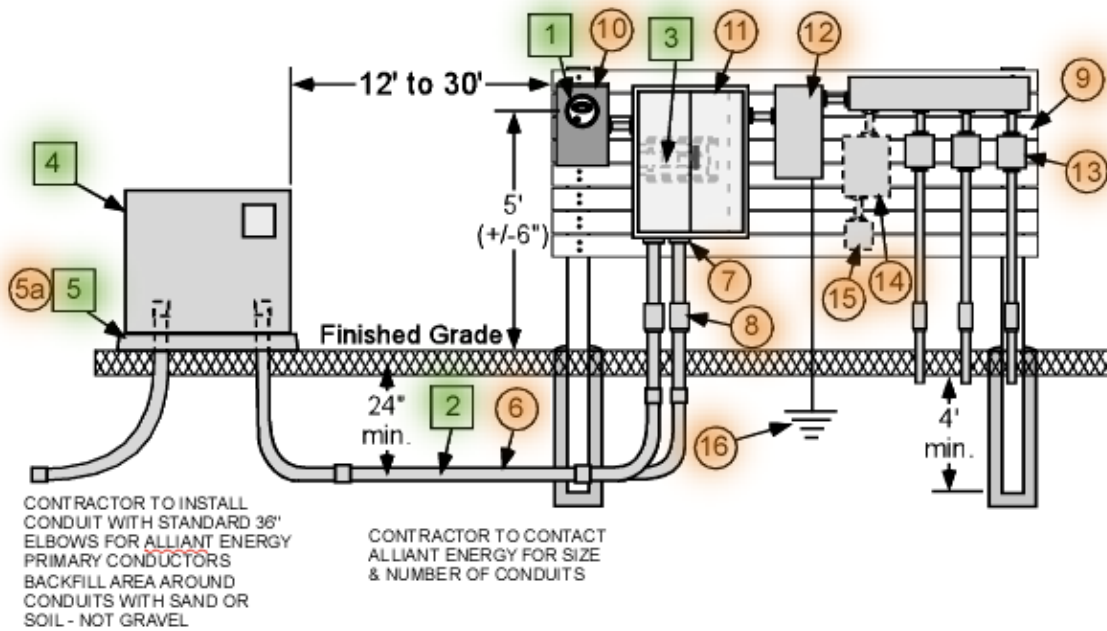

ESR 806C.cvx

**807. OVERHEAD SERVICE TO A FARM YARD-POLE, WITH POLE TOP TRANSFER SWITCH (Site-Isolation Device) FOR MAINTENANCE ONLY**

301 - 600<sup>(4)</sup> AMP - SINGLE PHASE - 120/240 VOLT

301 - 600<sup>(4)</sup> AMP - THREE PHASE - 120/208 VOLT

100 - 600<sup>(4)</sup> AMP - THREE PHASE - 277/480 VOLT

Item No.	Description	■	●
		Furnished & installed by Utility	Furnished & installed by Customer
1	Service drop	X	
2	Current transformers	X	
3	Potential transformers	X	
4	Meter	X	
5	Pole - treated 35' class 5 minimum		X
6	Pole top transfer switch (2-pole for 1-phase, 3-pole for 3-phase)		X
7	Metering conduit (1" rigid galvanized steel RGS)		X
8	Approved meter socket (See ESE e-manual E105)		X
9	Customer's overhead circuit		X
10	Down guy, anchor and guy guard		X
11	Stand-by generator circuit (optional)		X
12	Operating handle for pole top disconnect		X
13	Ground in accordance with the <i>NEC</i> (See ESR e-manual Chapter 14)		X

**NOTES:**

1. The site-isolation device option only applies to farms that meet the requirements in note 2, herein. Otherwise, the farm must be served per the other sections in Chapter 8, Farm Services.
2. A Site-Isolation Device shall apply to *NEC* 547 agricultural buildings or that part of a building or adjacent areas of similar or like nature as specified in:
  - a. Agricultural buildings where excessive dust and dust with water may accumulate, including all areas of poultry, livestock and fish confinement systems, where litter dust or feed dust, including mineral feed particles may accumulate.
  - b. Agricultural buildings where a corrosive atmosphere exists.
3. Customer to mount instrument transformer bracket(s).
4. 600 Amp continuous duty or 800 Amp intermittent duty service equipment.
5. If large equipment is to be driven under the service drop, reference NESC. Drop shall be a minimum of 18 feet above ground at the lowest point.
6. Sites with multiple service points require each service point to be identified per *NEC* 547.
7. All loads (customer circuits) must be fed overhead only for this type of construction.



**807. OVERHEAD SERVICE TO A FARMYARD-POLE, WITH POLE TOP TRANSFER SWITCH (Site-Isolation Device) - CONTINUED**

301 - 600<sup>(4)</sup> AMP - SINGLE PHASE - 120/240 VOLT

301 - 600<sup>(4)</sup> AMP - THREE PHASE - 120/208 VOLT

100 - 600<sup>(4)</sup> AMP - THREE PHASE - 277/480 VOLT

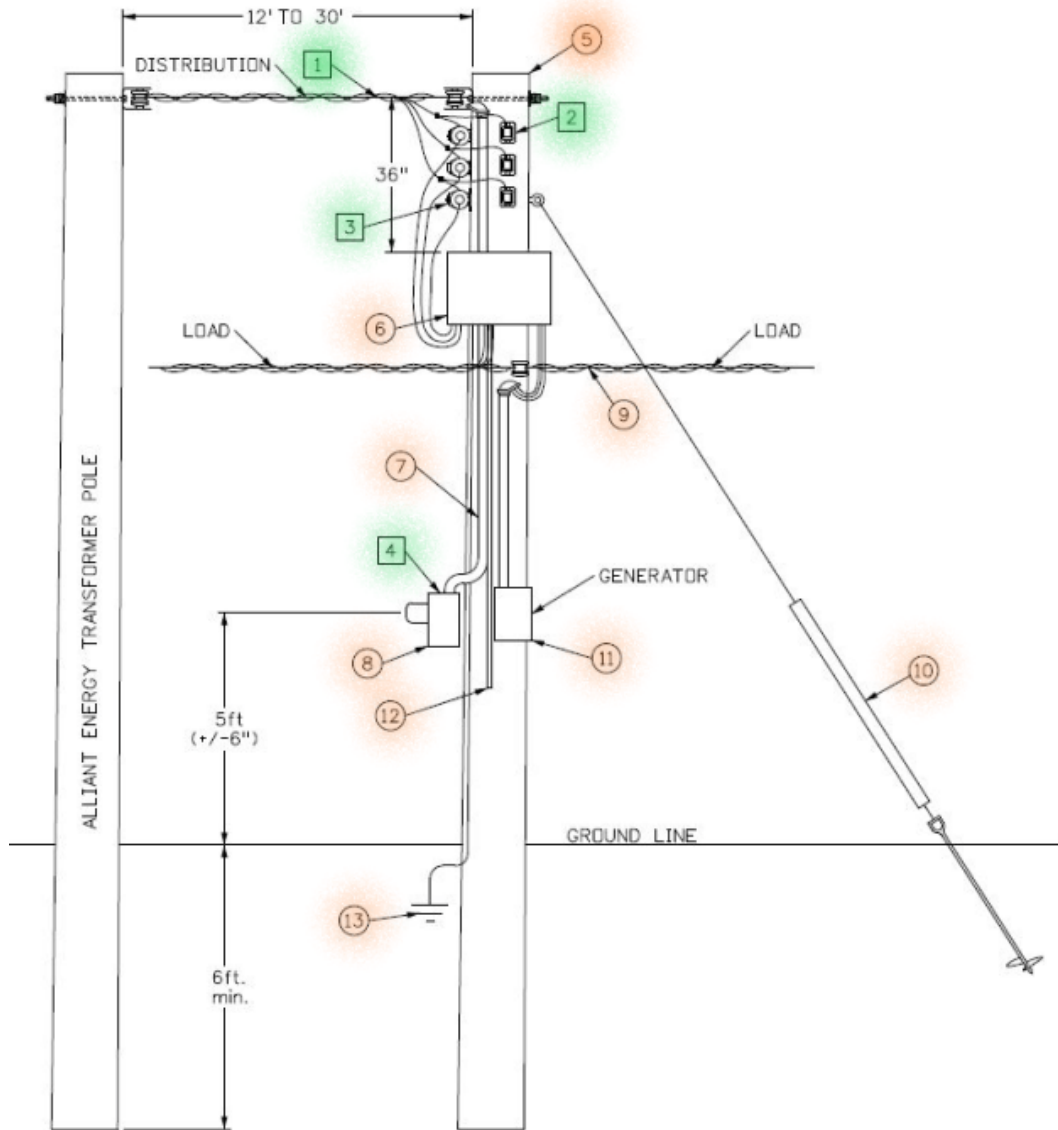

ESR 807.dgn

Note – All loads (customer circuits) must be fed overhead only for this type of construction.

Alliant Energy

# Chapter 9

Electric Service Rules

**RESERVED FOR NOTES:**



## CHAPTER 9

### ELECTRIC SERVICE RULES – UTILITY/CATV SERVICES

---

#### 900. GENERAL

This section has been established for electric service requests from other utilities; telephone, telecommunications, cable television, Department of Transportation and local municipalities. Many of these services include a request to place a meter socket and/or disconnect devices on Alliant Energy poles which shall meet Grade B construction.

If the request for attachment is wire, fiber, wi-fi devices, distributed antenna systems, or small cells, the Attaching Entity must apply to attach and be approved to attach before any of these attachments are placed on Alliant Energy poles. Failure to get approval will result in immediate removal of the non-approved facilities. These requests are managed by the Alliant Energy Joint Facilities Dept. Please contact at [jointfacilities@alliantenergy.com](mailto:jointfacilities@alliantenergy.com) for further information or visit the website, <https://www.alliantenergy.com/PartneringwithAlliantEnergy/PoleAttachments>.

Requests involving attachments of customer equipment, disconnects, power supplies, risers and meter sockets can create conditions where the pole becomes cluttered, making it very difficult and dangerous to climb.

- A. Alliant Energy will not allow new meter sockets on poles. Metering facilities will not be allowed on Alliant Energy poles, except where entities have previously been allowed to attach metering facilities (due to prior rules that allowed this practice). Current rules do not allow metering facilities to be on a pole. If there is a mitigating factor, please request a variance from the ESR Committee and the Joint Facilities department.
- B. Poles with transformers, capacitor bank, risers, three-phase switches, three-phase buck arm corners or taps should be avoided if possible. If such poles are requested, then a review by Alliant Energy will be conducted to determine feasibility. Attachers that need power for their equipment (such as small cells, Wi-Fi, and antennas,) should work with Joint Facilities and determination what will be allowed (power equipment, metering, etc.) and be made as part of that project. Under Joint Facilities, the attacher may be able to attach to poles (non-wood street light poles, ornamental lighting poles, capacitor bank poles, risers, three-phase switches, and three-phase corner pole or taps) as long as they are responsible for the costs to upgrade the pole, and there are no safety issues. The attachment request to those pole types will be reviewed and approved via a coordination between Facilities, Operations, and Standards.
- C. When the customer's equipment, risers and meter-sockets are allowed by variance only on Alliant Energy poles, they shall not occupy more than two adjacent quadrants. Clearances shall be maintained as indicated in the NESC, *NEC* and any local or state codes.



- D. Alliant Energy personnel will review municipal attachment requests for holiday lights or decorations on poles. These attachments may be allowed if adequate space is available to meet NESC requirements and if the customer provides a fused weather tight GFCI receptacle at the point of service connection. All wires serving holiday decorations will be strung from pole to pole. In no case will Alliant Energy provide service to holiday decorations from pole to building.
- E. Requests for underground service to customer owned underground termination and/or metering facilities may or may not meet requirements set forth by Alliant Energy for service. Alliant Energy will evaluate each request on an individual basis.  
The preferred method for these types of services will be to an approved meter pedestal with or without fused disconnects as shown in section 902.
- F. Request for planned over lashing shall require 15-day advance notice. Contact Joint Facilities at [jointfacilities@alliantenergy.com](mailto:jointfacilities@alliantenergy.com) for further information (FCC Order 7762,115;47CFR 1.1415c)

**ELECTRIC SERVICE RULES**

**UTILITY/CATV SERVICES**

**Issued Jan 2024**

**901. UTILITY/CATV POLE-MOUNT SERVICE, 120/240 VOLTS, SINGLE-PHASE, 3-WIRE, 200 AMP MAX CATV, TELEPHONE, MUNICIPAL (Maintenance Only, not for new construction)**

Item No.	Description	■	●
		Furnished & installed by utility	Furnished & installed by customer
1	Service weather head		X
2	Service entrance rigid conduit		X
3	Service entrance conductors		X
4	Weather-proof service fused disconnect		X
5	Cable TV power supply or equivalent device		X
6	Ground in accordance with the <i>NEC</i> (See ESR e-manual Chapter 14)		X
7	8' ground rods (quantity as required)		X
8	Approved meter socket (See ESE e-manual E103)		X
9	Service conductors and connections	X	
10	Meter	X	

**NOTES:**

1. Non-metallic conduit, (Schedule 80). If metallic conduit is used, it shall be covered with a non-metallic covering 40 inches above and 40 inches below any communication attachments.
2. The service entrance conductors shall extend at least 36” beyond the service head to permit proper connections.
3. The disconnect power supply unit, meter socket and TV cable shall be mounted on the same quadrant of the pole.
4. When a unit contains both the service switch and the power supply, installation height shall be in accordance with applicable codes.
5. Power supply units may not be mounted on poles where transformers, risers, vertical supply conductors to aerial services, switch handles, traffic signal, capacitor banks or similar equipment exists. Power supplies may not be mounted on three-phase distribution corner poles or tap poles.
6. When foreign facilities are attached to a pole supporting a lighting fixture, a clearance of 20” is required.
7. Bonding should be provided between all metallic power and communications apparatus.
8. Minimum wire size shall be number 6 AWG and maximum wire size shall be 4/0.
9. For commercial installations, residential meter sockets are acceptable for service entrances 60 amps or less. For service entrances 100 amps or larger, commercial meter sockets are required.
10. All installations shall conform to the NEC, the NESC, Iowa and Wisconsin state electrical codes for clearances and working space.

901. UTILITY/CATV POLE-MOUNT SERVICE, 120/240 VOLTS, SINGLE-PHASE, 3-WIRE, 200 AMP MAX CATV, TELEPHONE, MUNICIPAL (Maintenance Only, not for new construction)

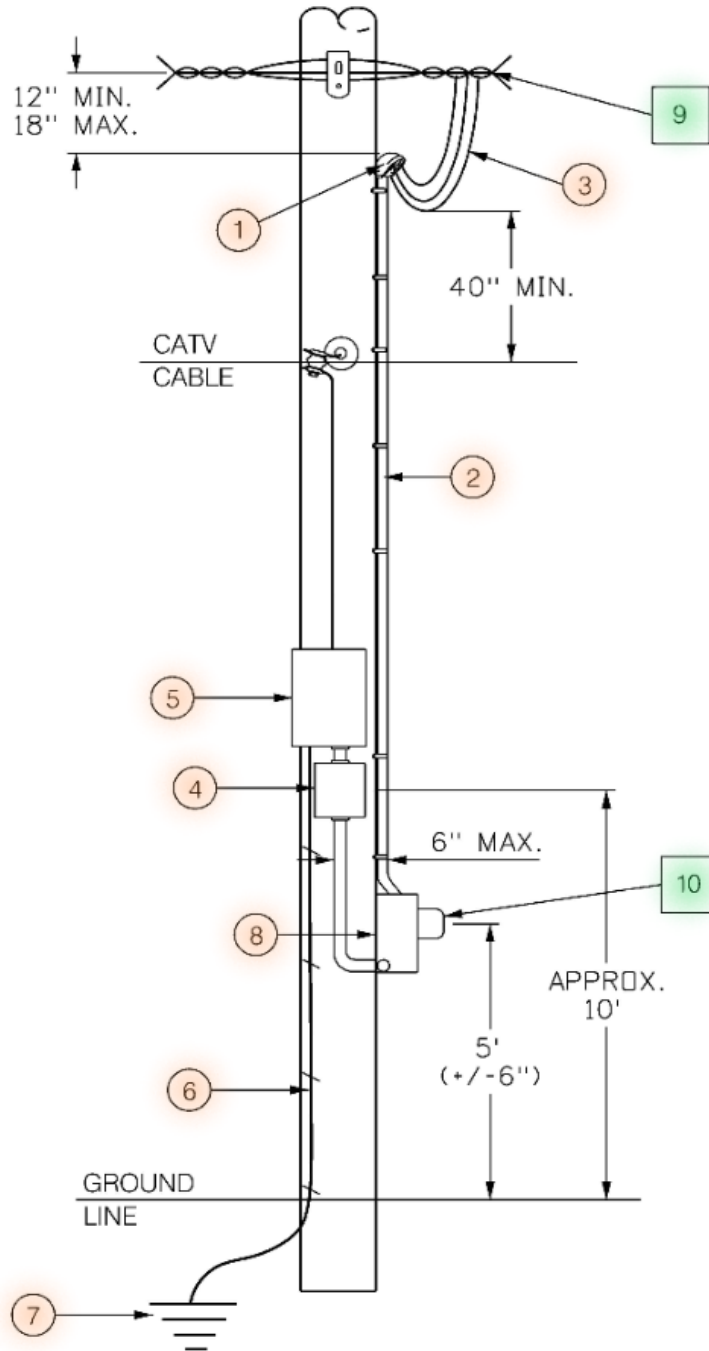

**ELECTRIC SERVICE RULES**

**UTILITY/CATV SERVICES**

**Issued Jan 2024**

**902. UNDERGROUND SERVICE, 120/240 VOLTS, SINGLE-PHASE, THREE-WIRE, 200 AMP MAX (CATV, TELEPHONE, MUNICIPAL)**

Item No.	Description	Furnished & installed by utility	Furnished & installed by customer
		■	●
1	Underground service lateral	X	
2	Meter	X	
3	U-Guard	X	
4	Alliant Energy facilities (riser pole or pad-mount transformer)	X	
5	Approved meter socket (See ESE e-manual E114)		X
6	Service entrance equipment		X
7	Pedestal stake (minimum 6 feet)		X
8	Ground in accordance with the NEC (See ESR e-manual Chapter 14)		X
9	Factory manufactured stabilization foot		X
10	Underground feeder circuit		X
11	Rigid conduit (for customer conductors when required)		X
12	Rigid conduit w/pull string (for service wires) - recommended		X

**NOTES:**

1. Grounding electrodes shall be installed per the NEC.
2. A minimum of 12 feet of clear space is required from customer owned equipment to Alliant Energy facilities (riser pole, pad-mount transformer or pedestal) in rural areas where livestock may be present or in areas where a truck may need to gain access between Alliant Energy facilities and customer equipment.
3. With Alliant Energy approval the minimum clear space from note 2 may be reduced to 5 feet in residential subdivisions and urban areas when the customer owned equipment is served from an Alliant Energy owned pad-mount transformer or pedestal.
4. Item # 11, when the entrance trough on a meter pedestal is not divided for metered and un-metered conductors, the contractor shall provide a conduit exit from disconnect device.
5. The bottom of the disconnecting means shall be mounted a minimum 2 feet above finished grade or a platform.
6. Bonding should be provided between all above ground metallic supply and communications enclosures (pedestals, terminals, apparatus cases, transformer cases, etc.) that are separated by a distance of 6 feet or less. (NESC 384.C)
7. Minimum wire size shall be number 6 AWG and maximum wire size shall be 4/0.
8. It is recommended the customer install duct from their power pedestal to the nearest engineering specified Alliant Energy facility (riser pole or pad-mount transformer). A pull string is required for all services in conduit.
9. For commercial installations, residential meter sockets are acceptable for service entrances 60 amps or less. For service entrances 100 amps or larger, commercial meter sockets are required.

902. UNDERGROUND SERVICE, 120/240 VOLT, SINGLE-PHASE, THREE-WIRE, 200 AMP MAX (CATV, TELEPHONE, MUNICIPAL), CONTINUED

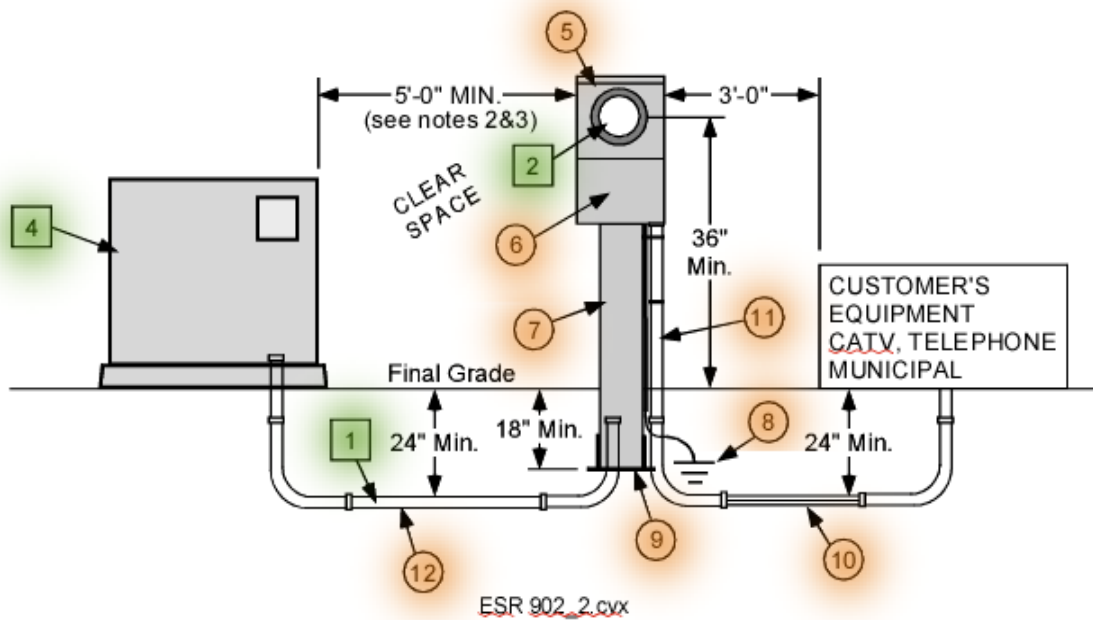
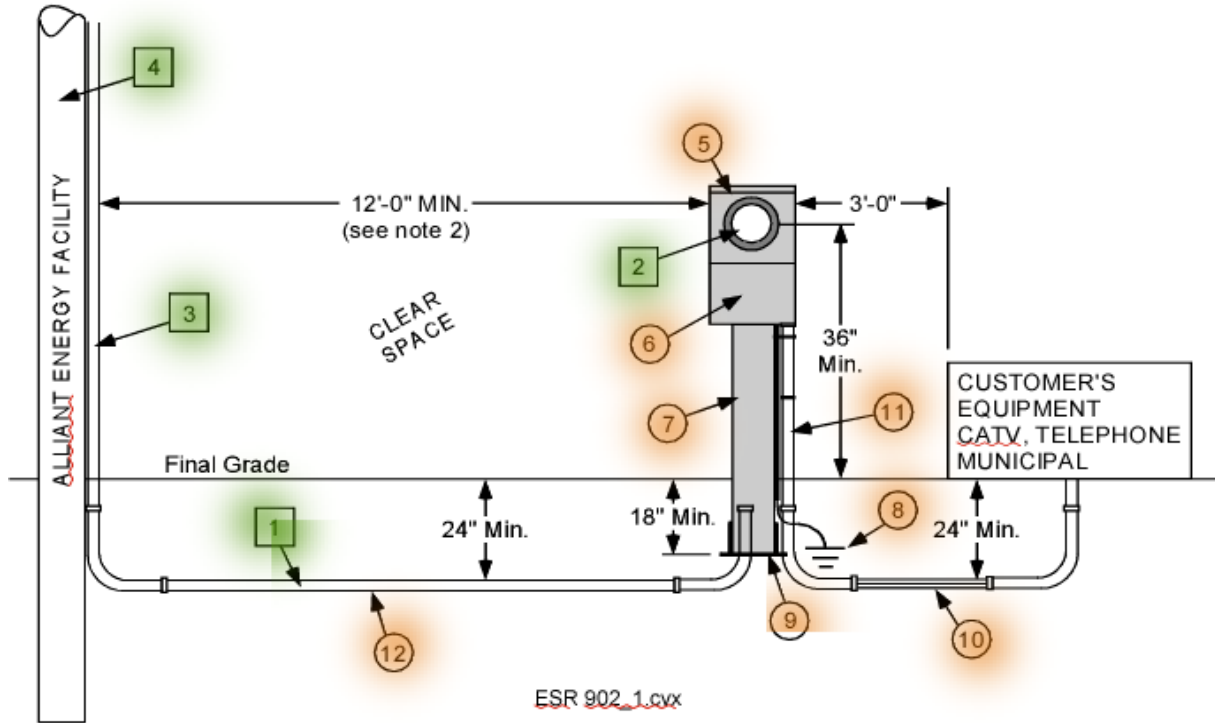



**903. CONNECT AMERICA OR LIKE APPLICATIONS - FIELD-BUILT STRUCTURES UNDERGROUND SERVICE, 120/240 VOLTS, SINGLE-PHASE, THREE-WIRE, 200 AMP MAX (CATV, TELEPHONE, MUNICIPAL)**

Item No.	Description	Furnished & installed by utility	Furnished & installed by customer
1	Meter	X	
2	Underground service lateral	X	
3	Rigid conduit		X
4	Insulating bushing		X
5	Conduit expansion joint		X
6	Field-built structure (see drawings/notes for details)		X
7	Commercial meter socket with lever bypass (See ESE e-manual E103)		X
8	Service entrance equipment/disconnect		X
9	Ground in accordance with the NEC (See ESR e-manual Chapter 14)		X

**NOTES:**

1. Alliant Energy engineering approval is required for use.
2. Structures are for use with limited communications equipment.
3. Item #7, horned bypass meter socket may be acceptable with a maximum 60 amp main.
4. All wood shall be commercially treated against decay.
5. Posts shall be buried a minimum of 4 feet deep and set plumb.
6. Planks shall be level and fastened with galvanized hardware (bolts, washers, nuts, etc.); nails and screws shall not be used.
7. All service equipment shall be UL listed NEMA 3R, lockable and listed by an approved testing agency for service entrance use.
8. Customer is responsible for the maintenance, relocation or removal of the structure.
9. For use in DOT right-of-way please see ESR e-manual 609A - Contact Alliant Energy or the DOT with further questions.
10. Field-built structures shall be located a minimum of 12' from Alliant Energy OH facilities (See ESR e-manual 902 note #2).
11. Equipment limited to meter socket and disconnect. (See ESR e-manual drawing 903B).

903A. CONNECT AMERICA - FIELD-BUILT STRUCTURES

8"x8" POST

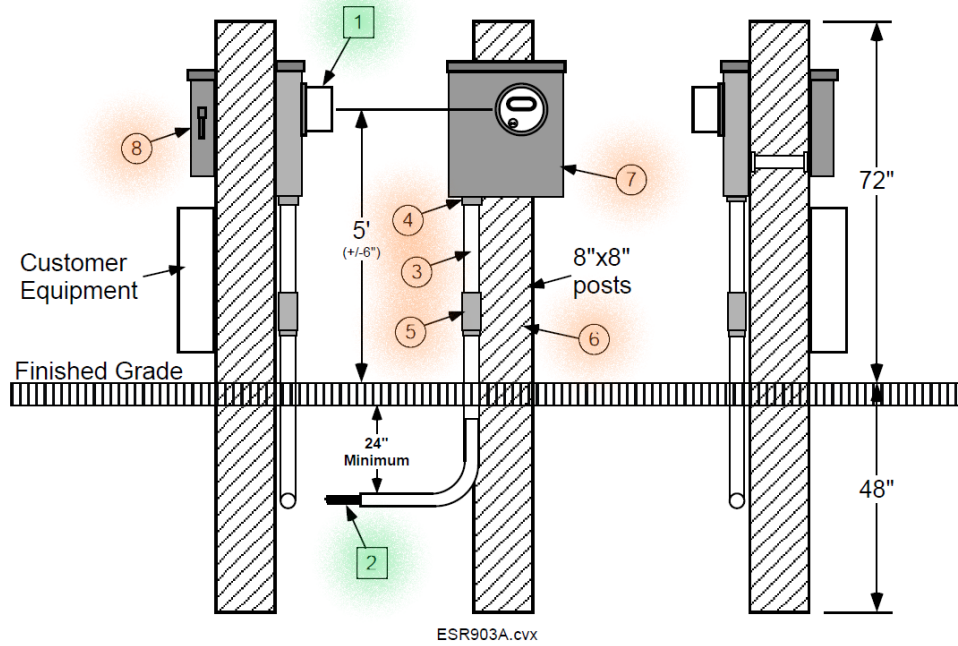

903B. CONNECT AMERICA - FIELD-BUILT STRUCTURES

4"x4" POSTS WITH 2"x12" PLANKS

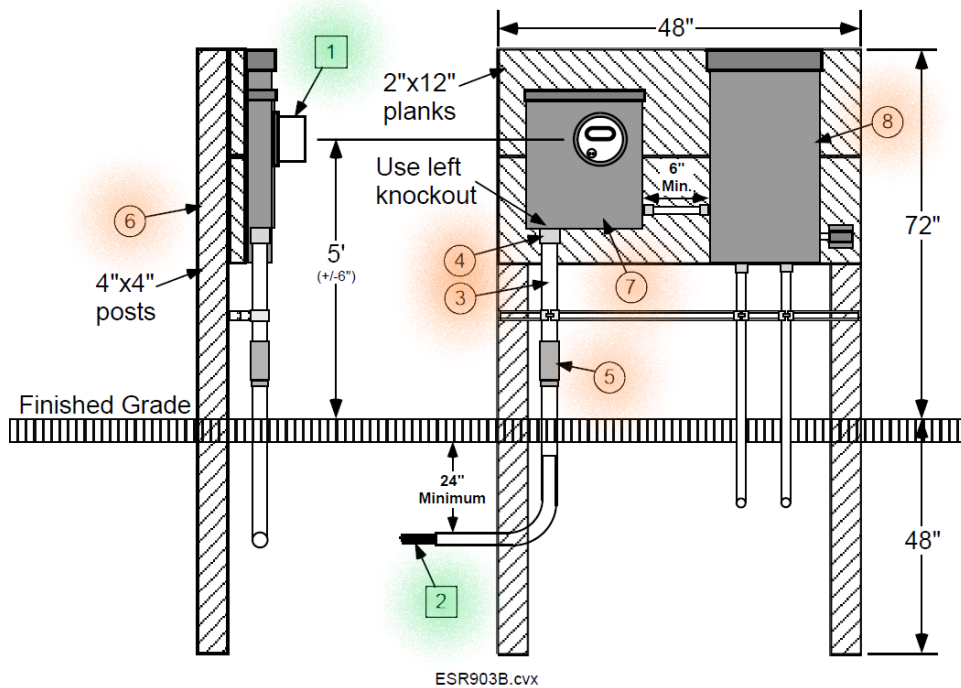

904. NON-METERED HOLIDAY LIGHTING  
(Only in Areas Where Permitted)

HOLIDAY LIGHTING-  
ATTACHMENT AGREEMENT / APPROVAL  
FROM UTILITY (AE) IS REQUIRED  
IN ALL CASES

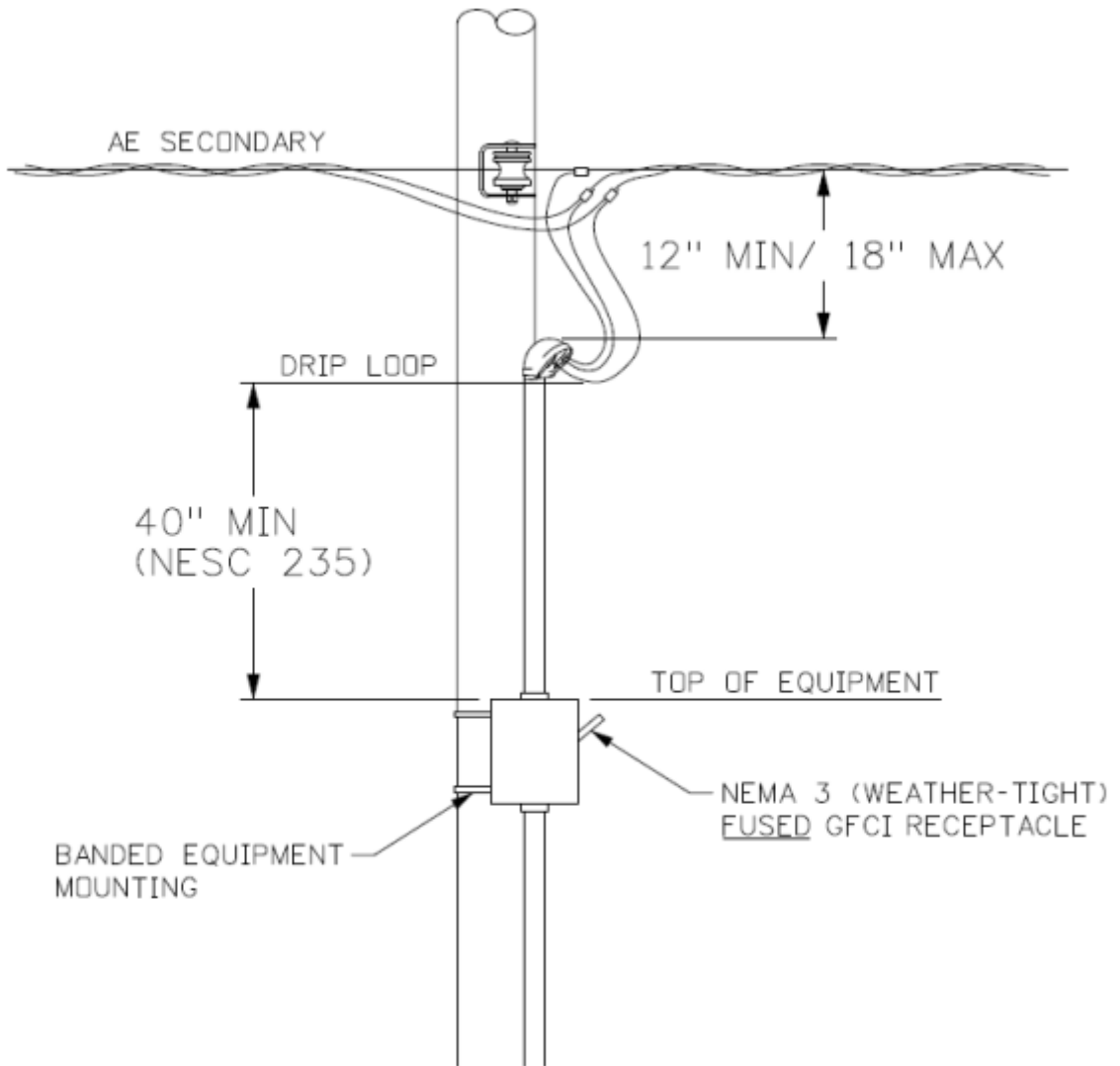

ESR 904.dgn

905. METERED HOLIDAY LIGHTING  
(Only in Areas Where Permitted)

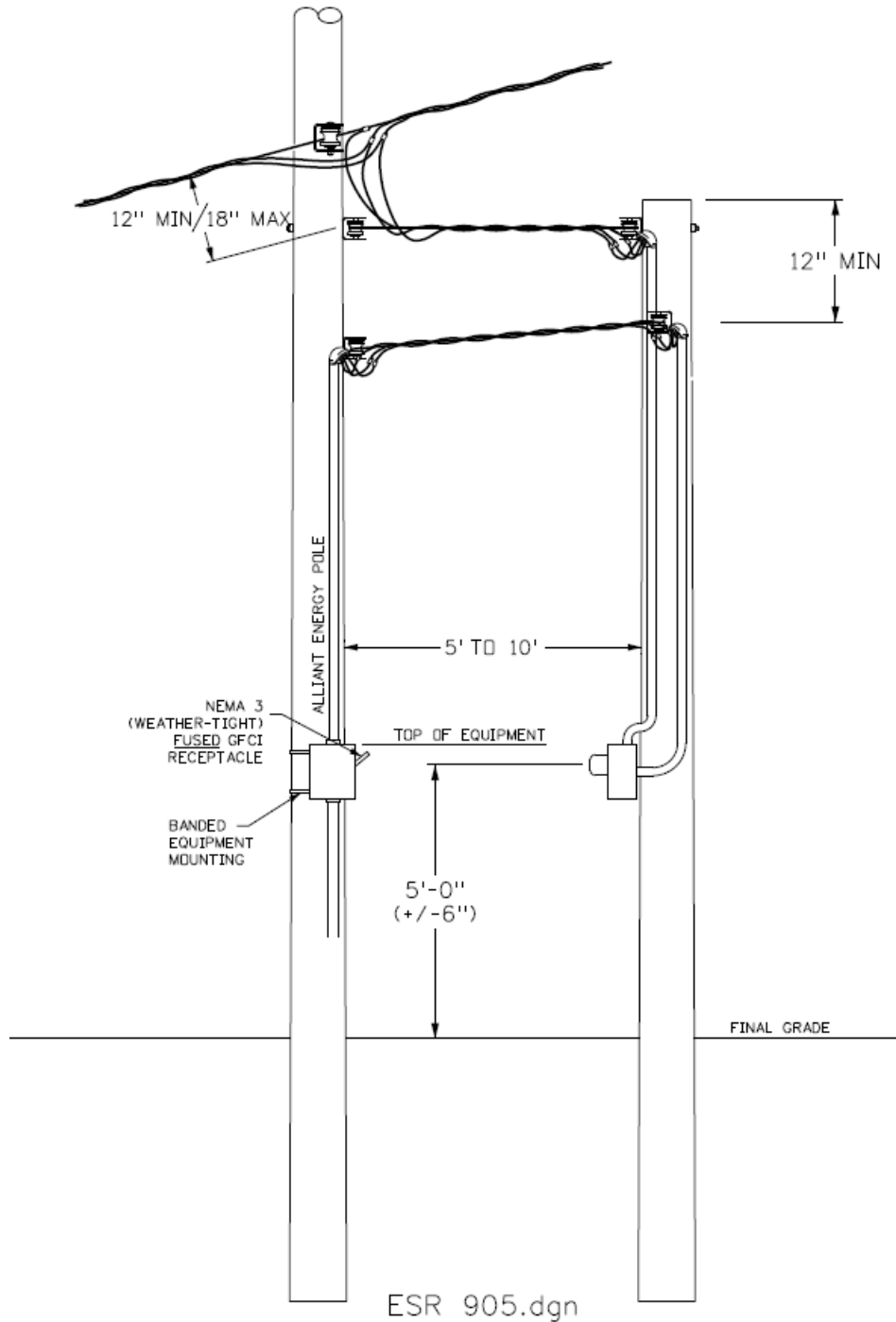

906: MAKE READY NESC MINIMUM REQUIREMENTS FOR STREET LIGHTING

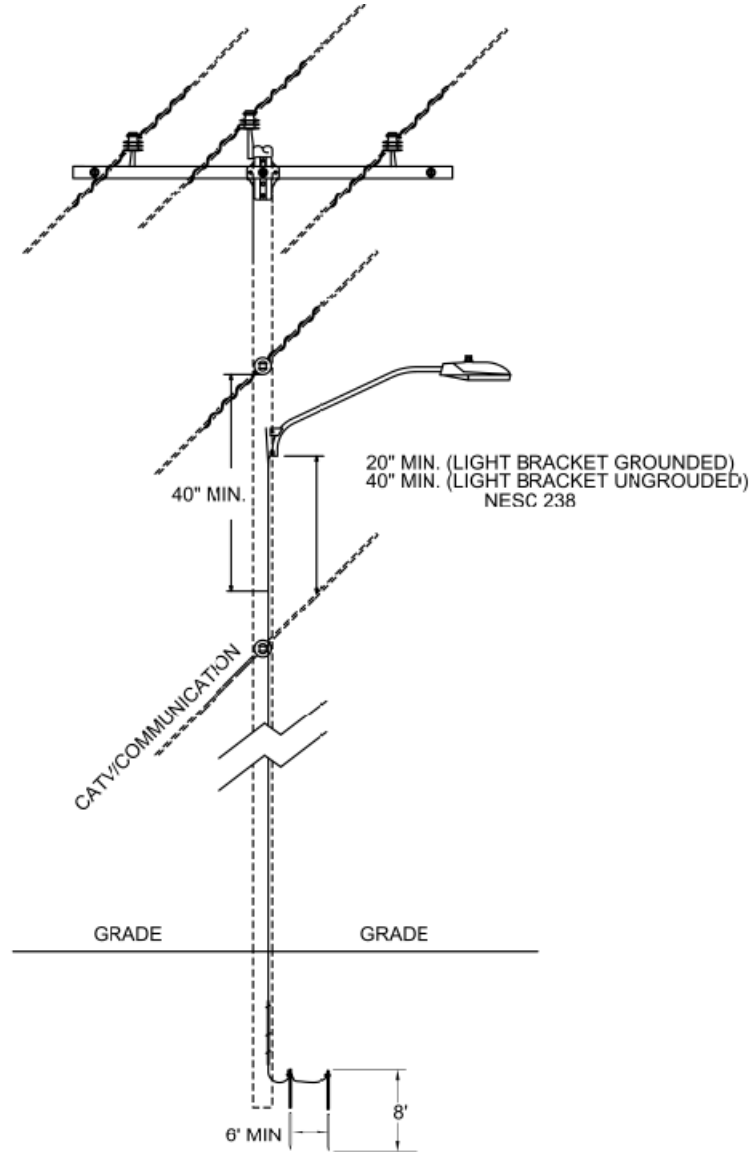

ESR 906.dgn

NOTES:

1. For items not shown, mid-spans and other clearances, contact Alliant Energy.

907. SMALL CELL EQUIPMENT INSTALLATION

Item No.	Description	■	●
		Furnished & installed by utility	Furnished & installed by customer
1	Service weather head (12" pigtails for connection)		X
2	Rigid conduit (for customer conductors)		X
3	Service Connection to weather head	X	
4	Approved UL listed NEMA 3R service disconnect.		X
5	Customer Owned Equipment		X
6	Ground in accordance with the NEC (See ESR e-manual Chapter 14)		X
8	Approved Meter Pedestal (See ESE e-manual E115)		X
9	Alliant Energy Owned Pole	X	
10	Meter	X	

**NOTES:**

1. Grounding electrodes shall be installed per the NEC.
2. A minimum of 12 feet of clear space is required. 20 feet is preferred from customer owned equipment to Alliant Energy facilities (riser pole, pad-mounted transformer or pedestal) areas where a truck may need to gain access between Alliant Energy facilities and customer equipment.
3. With Alliant Energy approval the minimum clear space from note 2 may be reduced to 5 feet in residential subdivisions and urban areas. Drawings VER-MRRU-1(OH) and VER-MRRU-1(UG).
4. Bonding should be provided between above ground metallic supply and communications enclosures (pedestals, terminals, apparatus cases, transformer cases, etc.) that are separated by a distance of 6 feet or less. (NESC 384.C)
5. Trench, conduits and conductors are supplied, owned and installed by customer.
6. Minimum wire size shall be number 6 AWG and maximum wire size shall be 4/0.

907A: OVERHEAD SMALL CELL EQUIPMENT INSTALLATION.

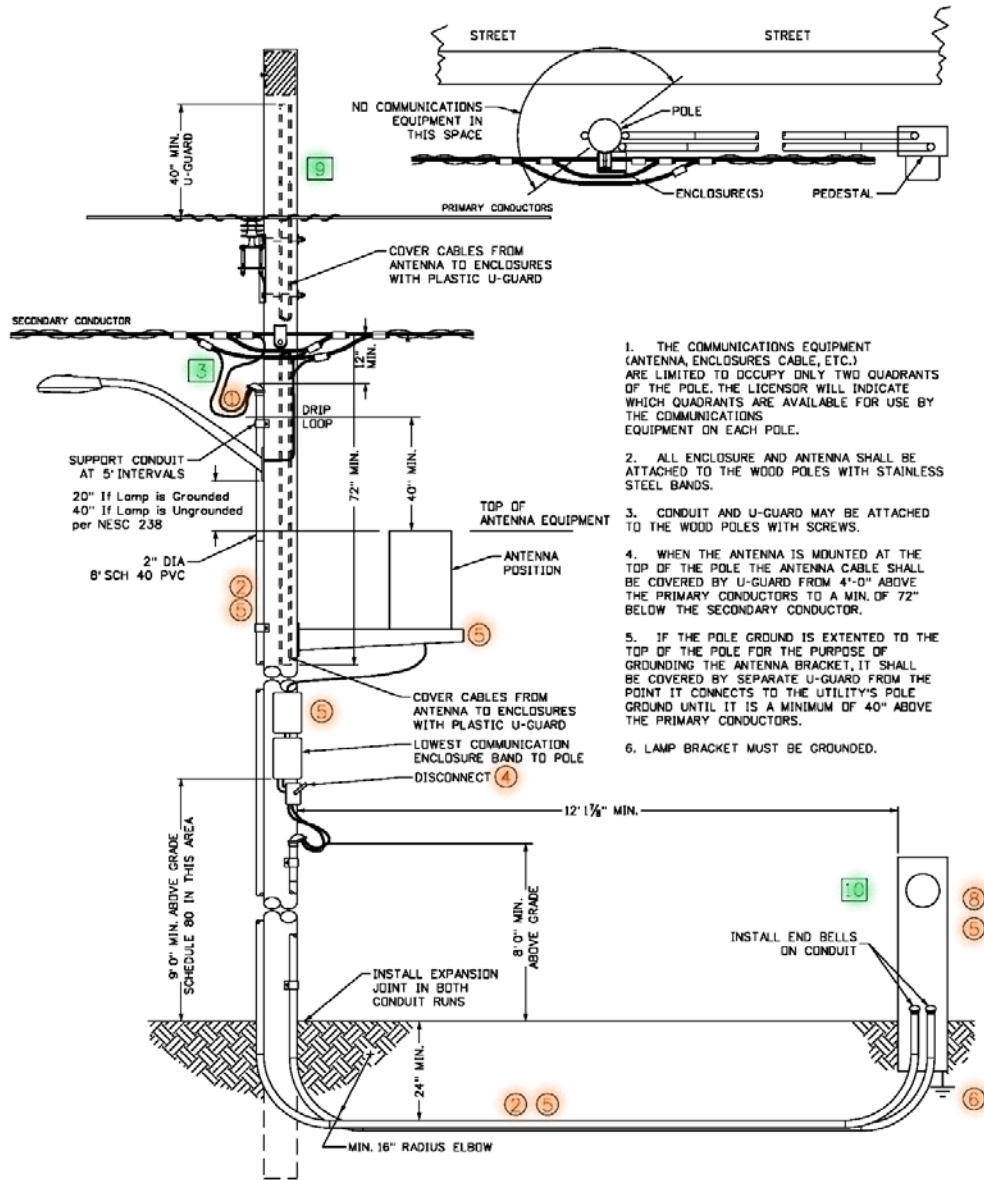

1. THE COMMUNICATIONS EQUIPMENT (ANTENNA, ENCLOSURES, CABLE, ETC.) ARE LIMITED TO OCCUPY ONLY TWO QUADRANTS OF THE POLE. THE LICENSOR WILL INDICATE WHICH QUADRANTS ARE AVAILABLE FOR USE BY THE COMMUNICATIONS EQUIPMENT ON EACH POLE.
2. ALL ENCLOSURE AND ANTENNA SHALL BE ATTACHED TO THE WOOD POLES WITH STAINLESS STEEL BANDS.
3. CONDUIT AND U-GUARD MAY BE ATTACHED TO THE WOOD POLES WITH SCREWS.
4. WHEN THE ANTENNA IS MOUNTED AT THE TOP OF THE POLE THE ANTENNA CABLE SHALL BE COVERED BY U-GUARD FROM 4'-0" ABOVE THE PRIMARY CONDUCTORS TO A MIN. OF 72" BELOW THE SECONDARY CONDUCTOR.
5. IF THE POLE GROUND IS EXTENDED TO THE TOP OF THE POLE FOR THE PURPOSE OF GROUNDING THE ANTENNA BRACKET, IT SHALL BE COVERED BY SEPARATE U-GUARD FROM THE POINT IT CONNECTS TO THE UTILITY'S POLE GROUND UNTIL IT IS A MINIMUM OF 40" ABOVE THE PRIMARY CONDUCTORS.
6. LAMP BRACKET MUST BE GROUNDED.

VER-MRRU-1 (DH).dgn

Minimum distance from pole to pedestal 12 ft min (farm area) and 5 ft (urban area).

907B: UNDERGROUND SMALL CELL EQUIPMENT INSTALLATION

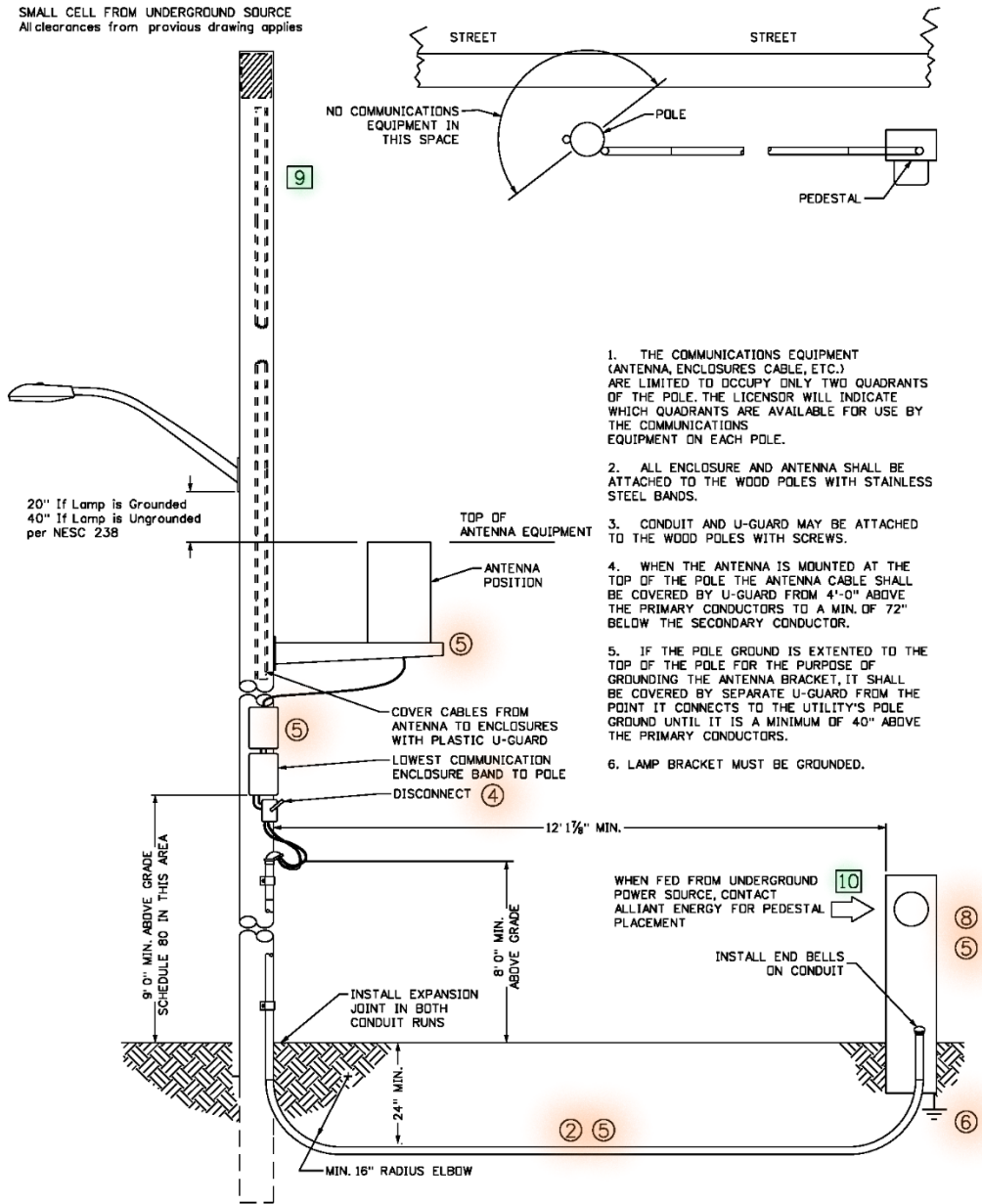

VER-MRRU-1 (UG).dgn

Minimum distance from pole to pedestal 12 ft min (farm area) and 5 ft (urban area).





**THIS PAGE INTENTIONALLY LEFT BLANK**

Alliant Energy

# Chapter 10

Electric Service Rules

**RESERVED FOR NOTES:**

## CHAPTER 10

### ELECTRIC SERVICE RULES – PRIMARY SERVICE

---

#### 1000. GENERAL

- A. This chapter contains information concerning primary metered service, defined as a service where the customer is served at a standard primary voltage.
- B. The primary service standard at Alliant Energy is underground 24.9kV. Alliant Energy requires the installation of 25kV rated metering equipment, overhead conductor, underground cable, switchgear and the use of 25kV high side rated transformers for all new installations, equipment upgrades or equipment replacements in all Alliant Energy service territory. Contact Alliant Energy to discuss non-standard primary service and equipment needs prior to designing or ordering.
1. Customer installs 25kV rated primary (>600V) equipment at the time of install. This includes, but not limited to, conductor, cable, transformers, and switchgear.
  2. Customer is only required to upgrade equipment that is being replaced during equipment replacements.
  3. Equipment will be energized at Alliant Energy's currently available voltage.
- Exceptions:
- 4kV Area Operating Exception: Areas of Alliant Energy currently operating at 4kV voltages, the customer may be allowed to install dual 15/4kV high side rated transformers only. All other equipment shall meet the requirements above.
  - Capacitor Banks – Customer may install capacitor bank equipment rated at the current operating voltage.
- C. For single phase primary voltage service, please consult Alliant Energy for the specific equipment requirements.
- D. The customer shall submit an application to Alliant Energy for the proposed primary service and obtain approval of the location, equipment and design before starting installation of the service entrance. Detailed shop drawings are required for underground service terminations and metering sections in switchgear.
- E. Alliant Energy furnishes, installs, and maintains all primary service conductors and/or cable terminators up to the point of service. Alliant Energy also furnishes, installs, and maintains the metering equipment (CTs and PTs) in accordance with applicable rates, extension rules and the requirements of the Electric Service Rule e-manual Chapter 1.
- F. The customer furnishes, installs, and maintains all service entrance facilities at the point of service including metering transformer cabinets to house metering CT's and PT's and the installation of 1" galvanized steel metering conduits where required.

- G. The customer will incur all costs for clearing either the overhead or underground routes, including tree removal, building and/or foundation or rubble removal and any other obstacles encountered.
  1. For all underground services: Prior to the installation of Alliant Energy’s underground service lateral, a 10-foot-wide cable route shall be free of all obstructions and within 6 inches of final grade.
  2. For all three-phase overhead services: Prior to the installation of Alliant Energy’s overhead service the customer shall provide a 30-foot-wide route free of all obstructions.
  3. For all single-phase overhead services: Prior to the installation of Alliant Energy’s overhead service the customer shall provide a 20-foot-wide route free of all obstructions.
- H. The customer shall provide the necessary easements, at no expense to Alliant Energy for the installation and maintenance of the primary service. No permanent buildings or trees shall be placed in the easement area.
- I. Prior to finalizing orders for service equipment, the customer shall submit a design package including but not limited to plan view and elevation view drawings, one-lines and equipment lists included in the installation to Alliant Energy Engineering and Metering for approval, to avoid delays and unnecessary expense for the customer and Alliant Energy.

Service entrance equipment located at the point of service shall include a three-phase, gang-operated load break disconnecting means and over current protection for a three-phase service. The disconnecting device shall be located to provide a visible open and operating capability to both the customer and Alliant Energy. The sequence of the equipment toward the load shall be **meter-switch-fuse** with variations approved by Alliant Energy. (See following diagram)

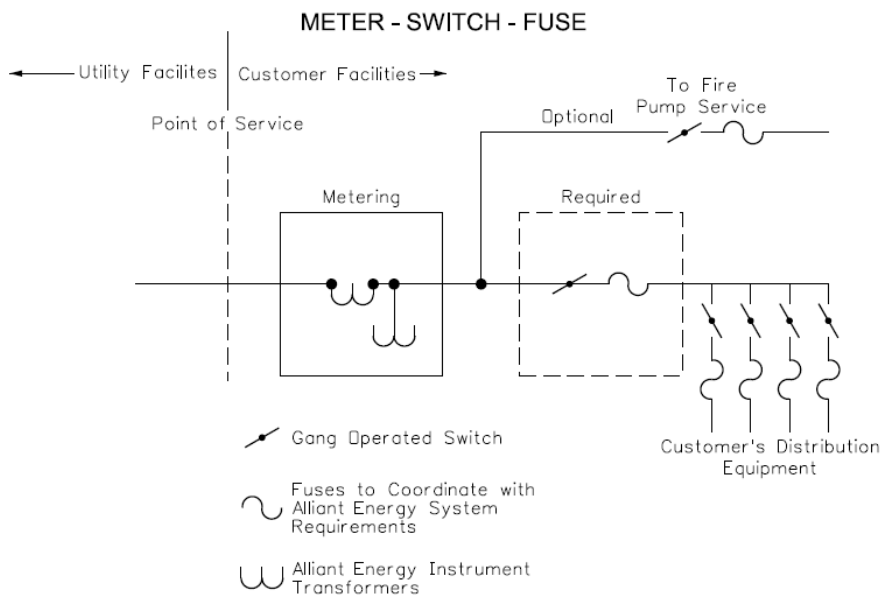

**1001. UNDERGROUND PRIMARY SERVICE TO METERING ENCLOSURE**

Item No.	Description	Furnished & Installed by Utility	Furnished & Installed by Customer
1	Underground primary service	X	
2	PT's and CT's	X	
3	Socket type meter or other revenue meter type	X	
4	Disconnect and arresters (on previous structure, not pictured)	X	
5	Primary metering enclosure (See Note 5 below)		X
6	Box pad		X
7	PT Fuse Holder		X
8	Arresters	X	
9	Approved meter socket if applicable (See ESE e-manual E105)		X
10	Underground primary cable with terminations and arresters		X
11	Switchgear		X
12	Switchgear pad		X
13	Grounding per NEC 250		X

**NOTES:**

1. Box pad shall provide a minimum of 30” height for training of primary cable.
2. Switchgear shall be located within 10 feet of metering enclosure to minimize the length of unprotected customer primary cable.
3. Switchgear shall have a main disconnect that is gang operated, operable by Alliant Energy and customer, lockable visual open, be capable of carrying full load requirements and withstanding faults of 10,000 amps (RMS symmetrical).
4. Consult Alliant Energy Metering for appropriate PT's and CT's, ordering procedure and shipment details to manufacturer for installation (If applicable).
5. PT fuse holders are required on all 25KV primary metering enclosures.
6. Approved dead-front primary metering transformer cabinets are listed in ESE e-manual section E310A.

1001. UNDERGROUND PRIMARY SERVICE TO METERING ENCLOSURE - CONTINUED

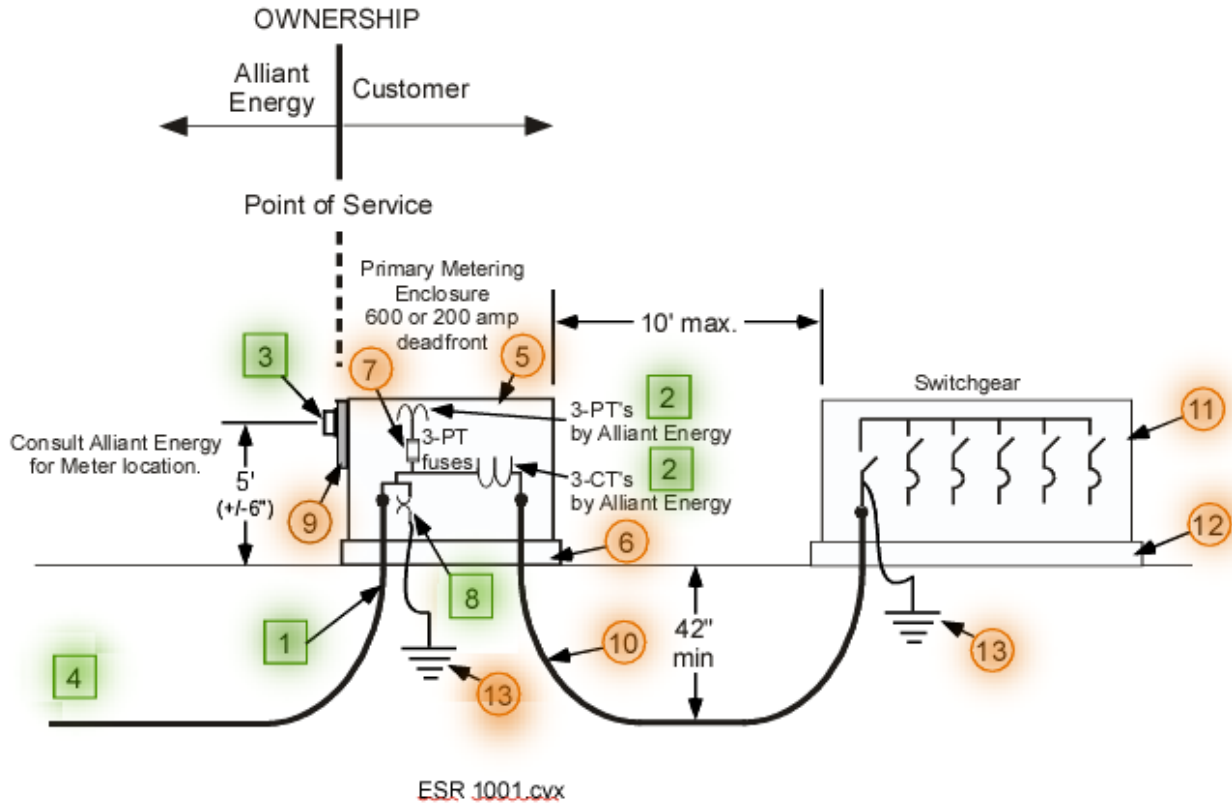

Contact Alliant Energy Engineering to provide means to disconnect service to this enclosure by closest upstream disconnection device for maintenance of PTs and CTs. Customer required to provide grounding means on load side of primary metering enclosure.

1002. UNDERGROUND PRIMARY SERVICE TO SWITCHGEAR

Item No.	Description	■	●
		Furnished & Installed by Utility	Furnished & Installed by Customer
1	Underground primary service cables	X	
2	Terminators	X	
3	PT's and CT's	X	
4	Socket type meter or other revenue meter type	X	
5	Primary switchgear		X
6	6" conduit		X
7	1" metering conduit		X
8	Approved meter socket if applicable (See ESE e-manual E105)		X
9	Grounding - Per NEC 250		X
10	Switchgear pad		X

**NOTES:**

1. Switchgear drawings shall be submitted to Alliant Energy for approval before ordering.
2. Utility cables entering the termination bay of the switchgear shall enter through the bottom. Clear space shall be provided for primary conductors below the termination points including room in the bottom of the cabinet(s) for 6" conduit to enter directly below the center point of the three termination points.
3. A single service disconnect is required. It shall be gang operated, be operable by the customer and by Alliant Energy, have means to show visual open contacts, be capable of carrying full load requirements and withstanding faults of 10,000 amps (RMS symmetrical).
4. Arrangements for double locking or other special procedures shall be discussed with Alliant Energy.
5. Minimum 10 feet of clearance shall be provided in front of termination and metering bays. If Alliant Energy is under contract to operate and maintain this switchgear, then the 10' clearance applies to all bays of the switchgear.
6. See ESE e-manual section E310B for additional information.

1002. UNDERGROUND PRIMARY SERVICE TO SWITCHGEAR – CONTINUED

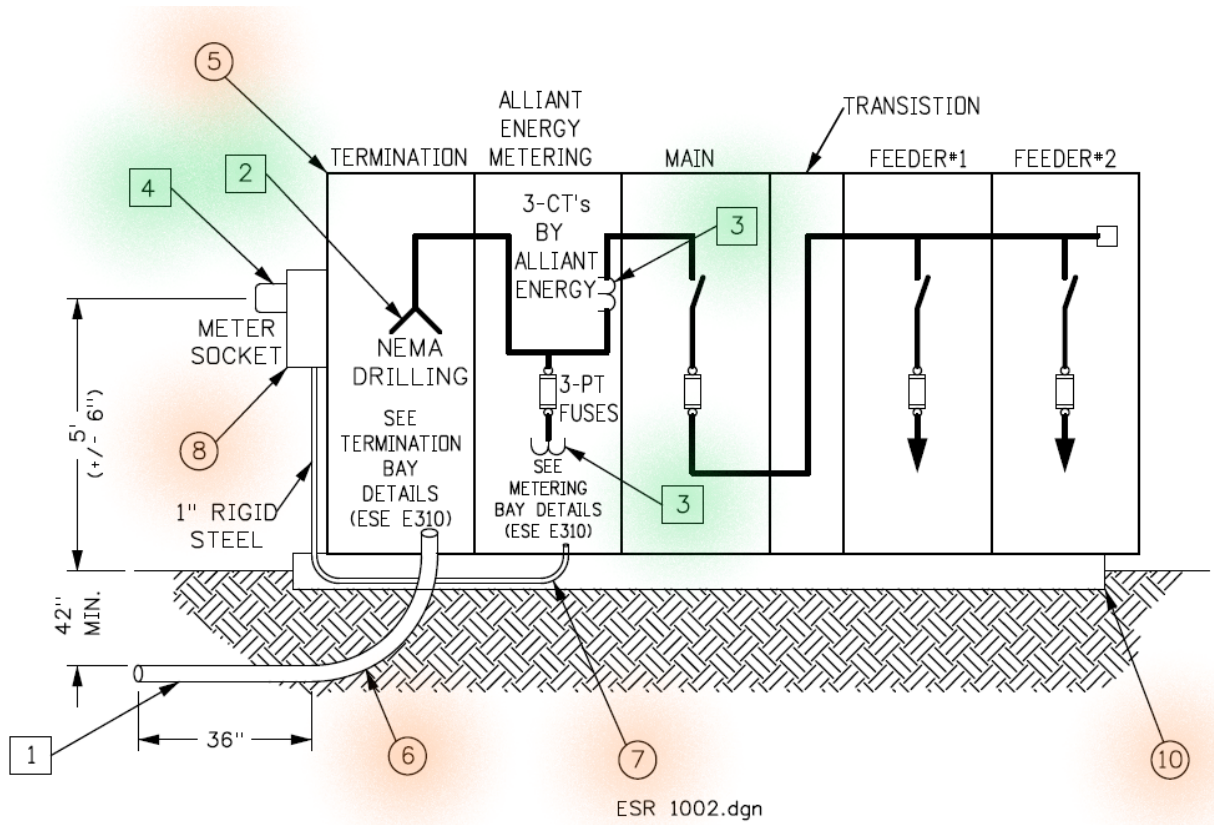

Sequence is Meter-Switch-Fuse



**1003. OVERHEAD PRIMARY SERVICE (BY VARIANCE)**

Only allowed when served from existing primary overhead



Item No.	Description	Furnished & Installed by Utility	Furnished & Installed by Customer
1	Overhead primary service conductors	X	
2	PT's and CT's with mounting hardware	X	
3	Socket type meter or other revenue meter type	X	
4	Dead-end shoes and insulators	X	
5	Disconnect and arresters (on previous structure, not pictured)	X	
6	Arresters - Recommended		X
7	Approved meter socket if applicable (See ESE e-manual E105)		X
8	Grounding Per NEC 250		X
9	Poles		X
10	Overhead primary conductor		X
11	Primary overcurrent protection		X
12	Rigid conduit for metering		X
13	Gang operated switch (See ESE e-manual E311D)		X
14	Insulator in switch operating rod handle		X

**NOTES:**

- Customer shall provide two poles of adequate height that allows ground clearance in accordance with all codes for primary conductors including the neutral. The poles shall be of adequate class to provide strength to support conductors with ice and wind loading per the NESC.
- The customer's isolation switch shall be gang-operated from grade level, be lockable in the open position, be operable by the customer and Alliant Energy, have means to show visible open contacts, be capable of interrupting all load being served, be capable of carrying all load requirements and withstanding faults of 10,000 amps (RMS symmetrical.)
- Main fuses or breakers shall have adequate load carrying capacity and a minimum interrupting rating of 10,000 amps, (RMS symmetrical.) The customer shall verify with Alliant Energy that all fuses and breakers coordinate with Alliant Energy's system.
- The customer shall supply a minimum 48" of vertical spacing for the installation of Alliant Energy's metering bracket with current and potential transformers. Alliant Energy will supply the bracket for these transformers.
- Branch circuit switches, operated at primary voltage, should meet operating criteria similar to the main fuse or breakers to provide adequate protection to the transformers served. Fuse size for Alliant Energy owned transformers will be specified by Alliant Energy.
- The customer shall provide adequate climbing space on the main service entrance structure as specified in the National Electrical Safety Code.
- Metering conduit is 1" rigid steel conduit with weatherproof NEMA 3R junction box. Maximum allowable conduit run is 50' with a total of 180 degrees in bends. Runs longer than 50' or runs with more than 180 degrees in bends shall be approved by Alliant Energy.
- Consult Alliant Energy Metering for appropriate PT's and CT's and ordering procedure. The meter cable will be furnished and installed by Alliant Energy.

**1003. OVERHEAD PRIMARY SERVICE – CONTINUED**  
 Only allowed when served from existing primary overhead

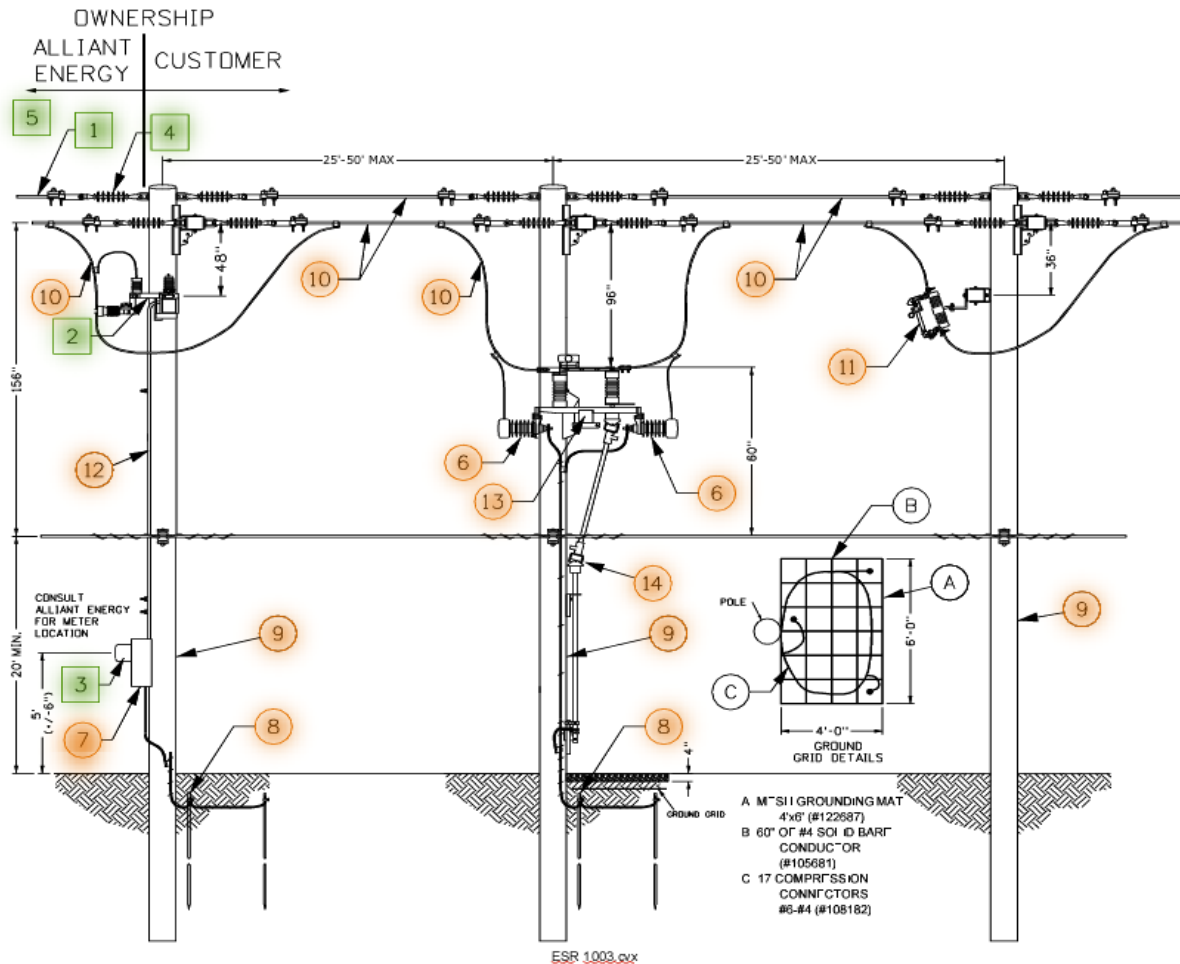

A Primary overcurrent protection device needs to be installed on a pole within 50 feet of the main disconnect as shown above, therefore, another pole may be required within the 50-foot distance. (NEC 230.91) Alliant Energy will install a set of arresters on the closest upstream pole from the metering pole to protect the CT's/PT's on the closest upstream pole.

**Further information on the requirements of Overhead Primary Service can be obtained from Alliant Energy.**

Alliant Energy

# Chapter 11

Electric Service Rules

**RESERVED FOR NOTES:**



## CHAPTER 11

### ELECTRIC SERVICE RULES – SPECIAL EQUIPMENT & MOTORS

---

#### 1100. SCOPE

This chapter covers the requirements for customer-owned equipment that may affect the quality of the service provided by Alliant Energy.

#### 1101. SERVICE IMPAIRING EQUIPMENT

- A. Service impairing equipment, because of its use, can lower the quality of power to other customers. Equipment that cannot be modified to prevent this shall be eliminated or controlled within performance limits required by Alliant Energy. If the customer meets these limits but still causes issues, such as but not limited to flicker, harmonic distortion, voltage fluctuation, the customer causing the issues shall have equipment installed at their expense that addresses the service impairment.
  - 1. Common types of service impairing equipment include welders, arc furnaces, electric motors, augers, conveyors, plasma cutters, motor driven compressors, instantaneous water heaters, distributed generation (Inverter based resources), power factor correction equipment or other equipment having highly fluctuating or large instantaneous demands.
  - 2. Other types of service impairing equipment include those with loads that cause harmonic distortion, such as data centers, inverter-based equipment, rectifiers, and variable frequency drives.
  - 3. Equipment causing high-frequency current or harmonic distortion shall comply with IEEE standard 519-2022.
- B. The customer shall obtain pre-approval from Alliant Energy before installing equipment such as those listed in Section 1101.A above.
- C. In most circumstances, Alliant Energy's electrical supply facilities are adequate to serve normal load additions. Customers installing service impairing equipment shall be billed the costs for additional facilities, metering and alterations specifically required to prevent impairment of service to other customers caused by this service impairing equipment.

#### 1102. PHASE BALANCE

- A. Customers should balance loads on their service.
- B. Customers shall make appropriate wiring changes on their side of the meter to utilize and balance all 3 Phases as best as practical.
- C. Each phase conductor should carry a minimum of 25% of the total kVA at normal operating and maximum load conditions.
- D. Exceptions to this rule may exist in certain locations as approved by Alliant Energy.
- E. Exceptions may also include lightly loaded systems.

- F. Imbalance shall not create negative system impact, negative customer impacts, or safety concerns.

### 1103. PROTECTION AND CONTROL

- A. The customer shall be responsible for the protection against voltage fluctuations, transients, sags and swells or phase loss wherever these or unexpected restarting could cause damage to the customer's equipment or result in personal injury.
- B. A control apparatus equipped with approved reverse-phase relays shall be installed by the customer on all poly-phase motor installations for:
1. Elevators, hoists, and cranes
  2. Manufactured processes where accidental reversal of rotation is liable to cause injury to persons or damage to machinery, equipment, or work in progress.

### 1104. MOTOR SPECIFICATIONS

- A. Single-phase motors that are started manually, or automatically more than four times per hour are classified as frequently started motors. A frequently started motor may be connected to 120, 240 or 208-volt circuits provided its locked rotor current does not exceed 60 amperes.
- B. All other single-phase motors may be connected to 120-, 240- or 208-volt circuits provided its inrush current does not exceed 100 amperes. Customers contemplating the purchase of any three-phase motors or single-phase motors rated more than 5 horsepower (HP), or having an inrush current greater than 100 amps, shall consult with Alliant Energy Engineering regarding the capacity and character of service available. The cost of additional facilities (including soft start equipment or variable frequency drives) that may be necessary to maintain service to other customers shall be at the expense of the customer who creates the voltage problem.
- C. In rural areas where no other customers are affected and where sufficient service and transformer capacity exists, infrequently started motors up to 10 HP single-phase/15 HP three-phase may be permitted with Alliant Energy Engineering approval. **Customers contemplating purchase or use of a motor greater than 5 HP single phase shall consult with Alliant Energy Engineering regarding the capacity and characteristic of service available.**

In order to determine whether a motor can be added Alliant Energy Engineering will require:

Provided by customer:

- Location (Address, street name, intersection, or nearest pole)
- Secondary Voltage
- Motor Size (HP)
- Motor Locked-Rotor Code

Provided by Alliant Energy Engineering:

- Transformer size and ratings
- Secondary Type
- Secondary Length

**ELECTRIC SERVICE RULES**

**SPECIAL EQUIPMENT & MOTORS**

**Issued Jan 2024**

An Alliant Energy Distribution Engineer will determine whether the motor will require soft start equipment or a variable frequency drive or if the motor can be infrequently started with no restrictions.

- D. Air conditioning systems, including air-to-air and geothermal heat pumps shall have Locked Rotor Current not to exceed 100 amps. Locked Rotor Amps (LRA) is usually listed on the unit's nameplate. LRA exceeding 100 amps is considered service impairing and requires consultation with Alliant Energy Engineering.
- E. If service to any customer is negatively affected, the cost of additional facilities necessary to provide adequate service shall be at the expense of the customer who causes the problem.

**1105. Maximum Permitted HP for Single-Phase Motors**

NEMA Locked Rotor Code	Max. HP Frequent Starts (>4 per hour)	Max. HP Frequent Starts (>4 per hour)	Max. HP Infrequent Starts (≤4 per hour)	Max. HP Infrequent Starts (≤4 per hour)
	120 Volt	208 or 240 Volt	120 Volt	208 or 240 Volt
A	2	4	3-1/2	7-1/2
B	2	3-1/2	3	5
C	1-1/2	3	3	5
D	1-1/2	3	2-1/2	5
E	1-1/2	2	2	5
F	1	2	2	4
G	1	2	2	3-1/2
H	1	1-1/2	1-1/2	3
J	1	1-1/2	1-1/2	3
K	3/4	1-1/2	1-1/2	2
L	1/2	1	1	2
M	1/2	1	1	2
N	1/2	1	1	2
P	1/2	1	1	1-1/2
R	1/3	3/4	3/4	1-1/2
S	1/3	3/4	3/4	1
T	1/3	1/2	1/2	1
U	1/3	1/2	1/2	1

1106. Permitted Maximum HP for Three-Phase Motors

NEMA Locked Rotor Code	Maximum HP Frequently Started Motors (>4 per hour)	Maximum HP Infrequently Started Motors (≤4 per hour)
A	5	10
B	5	10
C	5	10
D	3	7-1/2
E	3	7-1/2
F	3	7-1/2
G	3	5
H	2	5
J	2	5
K	2	3
L	2	3
M	1-1/2	3
N	1-1/2	3
P	1-1/2	3
R	1	2
S	1	2
T	1	2
U	1	1-1/2

1107. Permitted Maximum Amps for Motors

Equipment Rating	Total Locked Rotor Current of all components started Simultaneously Not to Exceed
120 Volt	100Amps
240 Volt up to 20,000 BTU/HR	100Amps
240 Volt over 20,000 BTU/HR	Consult Alliant Energy

Alliant Energy

# Chapter 12

Electric Service Rules

**RESERVED FOR NOTES:**





## CHAPTER 12

### ELECTRIC SERVICE RULES – STANDBY GENERATION

---

#### 1200. SCOPE

This chapter addresses any customer owned generation system not operated in parallel with Alliant Energy's electric distribution system including closed transition type transfer switches that parallel the generator system and the normal supply for a maximum of 100 milliseconds (1/10 second). See Chapter 5 for customer owned generator systems operated in parallel for greater than 100ms.

#### NOTES:

Closed transition = make before break, no disruption to load.

Open transition = break before make, requires disruption to load.

#### 1201. SAFETY

- A. The customer shall consult Alliant Energy before connecting any generating equipment to any customer circuit that is, or can be, supplied from Alliant Energy's electric distribution system.
- B. Transfer switches may only be located before the main service disconnects where they meet Chapter 1 Section 110 the short circuit duty (AIC Rating).
- C. The customer's transfer device shall be installed to mechanically prevent any possibility of power from the customer's standby source feeding back into Alliant Energy's distribution system.
- D. It is the responsibility of the customer to comply with all rules and labeling requirements of the *NEC* or any other jurisdictional codes. Permanent labeling is required; Labeling shall be rigid engraved plastic, engraved self-sticking brass or engraved self-sticking aluminum with a minimum of ¼ inch block lettering. Customer shall install a label at the meter reading "Standby Generation on-site".

STANDBY GENERATION  
ON-SITE

#### 1202. TRANSFER SYSTEM REQUIREMENTS

- A. Alliant Energy shall approve automatic transfer systems.
- B. The customer may supply any portion of their electrical load from a standby generator.
- C. The customer shall install a transfer switch or contactor (indoors or outdoors) in order to transfer load from ungrounded conductors between the normal supply and standby generator.
- D. All transfer switch devices that meet UL 1008 Rated and designed with Break-Before-Make connections will not require a Standby Generation Disconnect.
- E. Transfer Switches that do not meet UL 1008 shall have a lockable, visually open break in the circuit that isolates the utility normal supply from the customer's transfer switch. This break,

referred to as the Standby Generation Disconnect, shall be accessible to Alliant Energy and should be located within 10' of the meter, unless otherwise labeled.

- **Exception 1:** Pre-approved automatic transfer switches listed in ESE e-manual E311E with required labeling may be used without the Standby Generation Disconnect requirement.
  - **Exception 2:** Approved transfer switches listed in ESE e-manual E311A & E311B shall be installed according to ESR e-manual 807.
- F. Permanent labeling is required; Labeling shall be rigid engraved plastic, engraved self-sticking brass or engraved self-sticking aluminum with a minimum of ¼ inch block lettering. Customer shall install a label at the disconnect reading: “Standby Generation Disconnect”.
- G. Disconnection device shall be mounted at a height between 30 and 72 inches. Interconnection disconnect switch shall have a minimum of 6” vertical and horizontal separation from all other electrical equipment, non-electrical equipment, and all other obstructions. If these requirements cannot be met, they can be reviewed by Alliant Energy.

### 1203. TRANSFER SWITCH OPTIONS.

#### A. Permitted:

1. Manual or automatic double throw switches
2. Double throw relays
3. Mechanically interlocked switches
4. Breakers with factory designed mechanical interlocks

#### B. Not permitted:

1. Key interlocked switches or breakers
  2. Switches that plug into the meter-socket
  3. The addition of splices or taps in meter sockets and metering transformer cabinets
- **Exception:** Key interlocked switches or breakers are permitted for Farm Services with prior Alliant Energy Agricultural Rep. approval (See ESR e-manual Chapter 8)

### 1204. TRANSFER SWITCHES

- A. **Farmstead Pole-Top Transfer Switches are listed in ESE e-manual E311A (250V) (NEC 547.2 Site-isolating device)**
- B. **Farmstead Pole-Top Transfer Switches are listed in ESE e-manual E311B (600V) (NEC 547.2 Site-isolating device)**
- C. **Residential Grade-Level Transfer Switches With Meter Socket are listed in ESE e-manual E311C.**
1. Grade-level transfer switches with integrated meter-sockets are listed in ESE e-manual E311C.
- D. **Manually operated Grade Level Transfer Switches are listed in ESE e-manual E311D**
- E. **Grade Level Operated Pole Top Load Break Switches (Primary Voltage) are listed in ESE e-manual E311E.**
- F. **Self-Contained Grade Level Automatic Transfer Switches are listed in ESE e-manual E311F.**

**ELECTRIC SERVICE RULES**

**OPTIONAL STANDBY GENERATION**

**Issued Jan 2024**

1. Grade-level automatic transfer switches that have been pre-approved to meet the requirements of ESR e-manual 1202.D. Exception 1 when installed with permanent labeling and instructions are listed in ESE e-manual E311F.

2. Grade-level automatic transfer switches that have not been pre-approved and are not listed in the ESE e-manual may still be used but require the installation of a Standby Generation Disconnect and installation shall:

- a) Meet the requirements of the *NEC*
- b) Be listed by an approved testing laboratory, e.g., (U.L.)
- c) Meet ESR e-manual Chapter 12 requirements

**G & H. Grade Level Automatic Transfer Switches**

ESE e-manual Section	Phase	Voltage	Pre-Approved by Alliant see	Not Pre-Approved by Alliant
G1	1	240 VAC	ESE E311G1	See note 2
G2	1	480 VAC	ESE E311G2	See note 2
H1	3	240 VAC	ESE E311H1	See note 2
H2	3	480 VAC	ESE E311H2	See note 2

Notes

- 1. Pre-Approved grade level, automatic transfer switches shall meet the requirements of ESR e-manual (Chapter 12) 1202E and be installed with permanent labeling.
- 2. Grade-level automatic transfer switches that are not pre-approved and are not listed in the ESE e-manual may still be used but require the installation of a standby generation disconnect and the installation shall:
  - a) Meet the requirements of the *NEC*
  - b) Be listed by an approved testing laboratory e.g. (UL)
  - c) Meet ESR e-manual Chapter 12 requirements

1205. 1-PHASE/3-PHASE, FULL SERVICE BACKUP

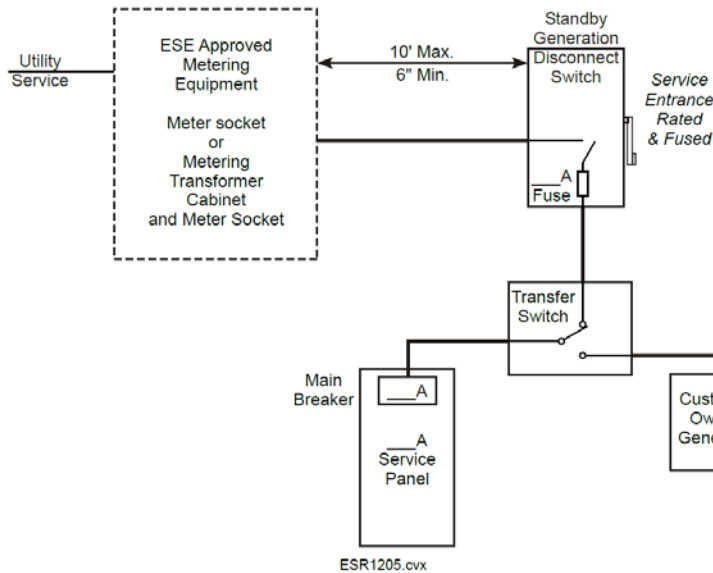

1205 Notes:

- *Modification to metering equipment is not allowed.*
- *If transfer switch is listed in ESE e-manual E311A, E311B or E311E, a separate standby generation disconnect switch is not required. See ESR e-manual 1202.E.*
- *If meter socket or metering transformer cabinet includes overcurrent protection (customer main) Standby Generation Disconnect does not need to be fused.*
- *All transfer switch devices that meet UL1008 Rated and designed with Break-Before-Make connections will not require a Standby Generation Disconnect as defined in Section 1202.D.*

1206A. 1-PHASE/3-PHASE, PARTIAL LOAD BACKUP OPTION A

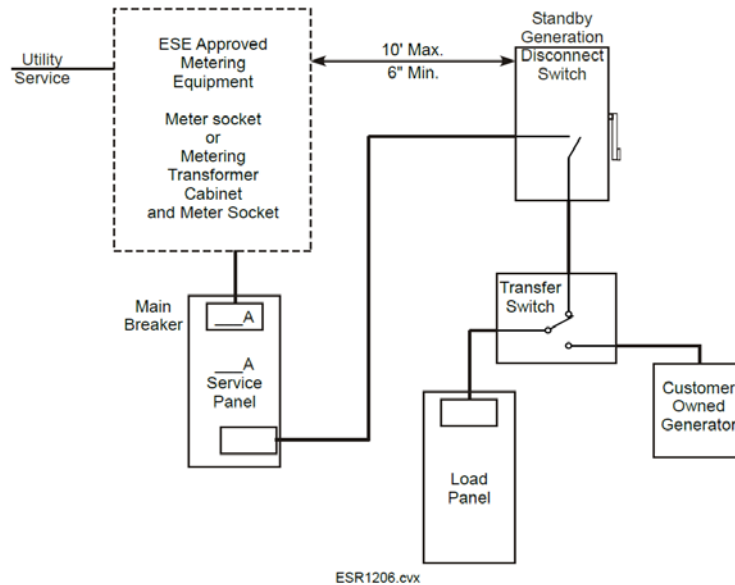

*1206A Notes:*

- *Modification to metering equipment is not allowed.*
- *If transfer switch is listed in ESE e-manual E311A, E311B or E311E, a separate standby generation disconnect switch is not required. See ESR e-manual 1202.E.*
- *If meter socket or metering transformer cabinet includes overcurrent protection (customer main) Standby Generation Disconnect does not need to be fused.*
- *All transfer switch devices that meet UL1008 Rated and designed with Break-Before-Make connections will not require a Standby Generation Disconnect as defined in Section 1202.D.*

1206B. 1-PHASE/3-PHASE, PARTIAL LOAD BACKUP OPTION B

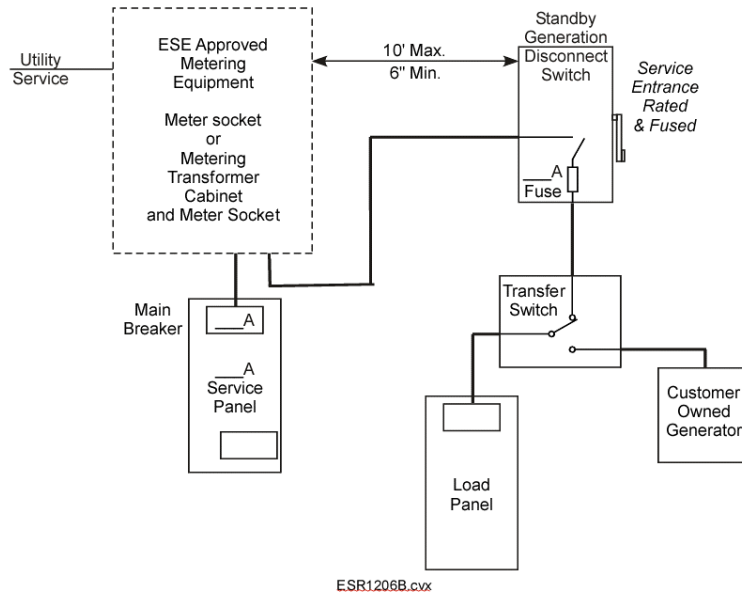

*1206B Notes:*

- *Modification to metering equipment is not allowed.*
- Two connections out of the metering equipment is allowed as long as factory lugs are available.
- *If transfer switch is listed in ESE e-manual E311A, E311B or E311E, a separate standby generation disconnect switch is not required. See ESR e-manual 1202.E.*
- *If meter socket or metering transformer cabinet includes overcurrent protection (customer main) Standby Generation Disconnect does not need to be fused.*
- *All transfer switch devices that meet UL1008 Rated and designed with Break-Before-Make connections will not require a Standby Generation Disconnect as defined in Section 1202.D.*

Alliant Energy

# Chapter 13

Electric Service Rules

**RESERVED FOR NOTES:**

# CHAPTER 13

## ELECTRIC SERVICE RULES – CLEARANCES

### 1300. SCOPE

This chapter covers the minimum clearances required by Alliant Energy for secondary and service voltages 480 volts or less. These requirements are designed to meet or exceed NEC, NESC, NFPA and state or building code minimum requirements.

Unobstructed work area clearance requirements are covered in ESR e-manual Section 606.

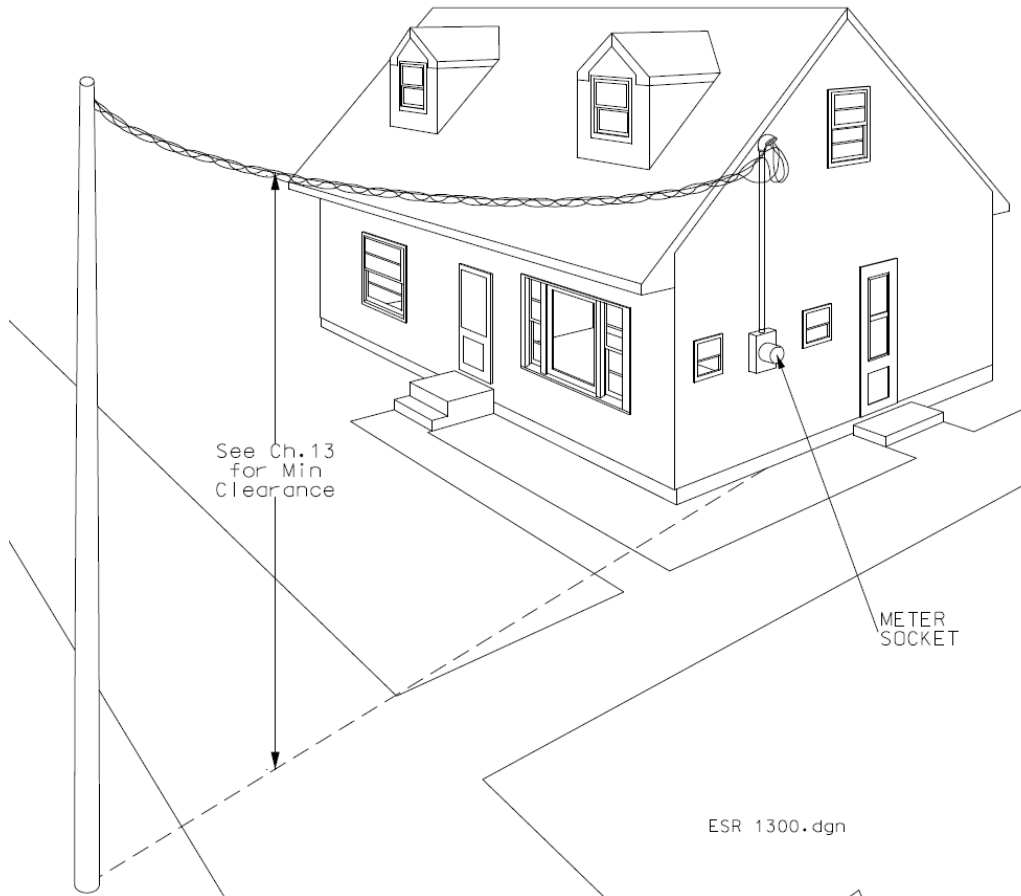



1301. MINIMUM CLEARANCES FOR SERVICES 300 VOLTS AND BELOW

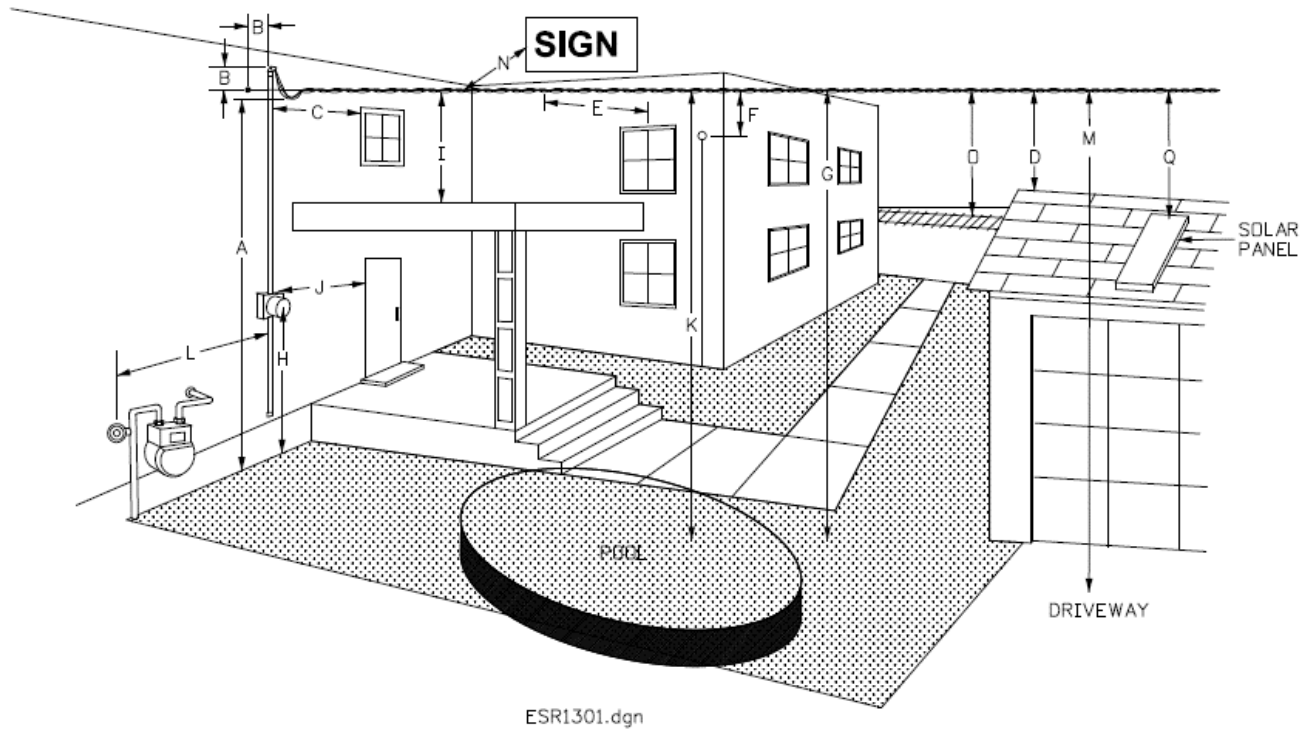

The NEC and NESC prescribe minimum clearances for service wires.

- A. 10-foot minimum to drip loops of triplex, if voltage to ground is less than 150 volts.
- B. 1-foot minimum and 2-foot maximum horizontal (left or right) and 6 to 12 inch vertical (above or below) between service head and attachment point.
- C. Exposed conductors shall be no less than 3-feet from window, doors, porches, fire escapes, awnings, signs and similar construction, when service is attached to building. The exposed service conductors shall be 3-feet from all sides except top of window. When the service conductors are attached above a window the drip loop shall not sag below the top of the window.
- D. Iowa follows the NESC clearances from Table 234-1 where a service passes over a building but does not attach, the vertical roof clearance shall be 11.0 feet if the roof is accessible, or 3.5 feet if the roof is not accessible. In Wisconsin, PSC 114.234(10)(b) changes the NESC requirements where the service passes over a building but does not attach to 8.0 feet over a roof that is accessible and 3.0 feet if the roof is not accessible and has a slope not less than 1 (vertical) to 3 (horizontal).
- E. 5-feet when wires pass opposite a window, where the service is attached. (NESC table 234-1)
- F. 2-feet from communication wires to supply cables 0 to 750V. (NESC table 233-1) For open supply conductor, this is increased to 4.0 feet.

- G. 12-foot supply cable to ground (0 to 750V). (NESC table 232-1.5.) Note 8: If the height of building does not permit 12-feet, it can be reduced to 10.5-feet (0 to 300V). If the voltage to ground is less than 150 volts, it can be reduced to 10-feet.
- H. Center of meter 5' +/- 6" feet above finished grade. (See ESR e-manual Section 602)
- I. On buildings where service attaches, the vertical clearance over a porch or balcony shall be a minimum of 10-feet if the area is accessible. For inaccessible areas it may be reduced. (NESC 234.C.3.d)
- J. When a door opens outward, mount the meter socket a door's width plus 6-inches on the hinged side away from the door opening. Do not mount the meter along high traffic passageways.
- K. See section 1303.
- L. A minimum horizontal separation of 3-feet shall be maintained between natural gas service equipment (vented regulators) and electric metering or termination equipment. Transformers shall have a minimum separation of 5-feet from natural gas service equipment. A minimum separation of 5-feet shall be maintained between electric metering or termination equipment and liquid petroleum facilities on site but not filled on site. If the liquid petroleum facilities are filled on site the minimum separation is 10-feet.
- M. 16-feet over a driveway may be reduced on residential only drives to 12.5-feet for insulated drops limited to 300 Volts to ground or 12-feet for triplex service drops limited to 150 Volts to ground. (NESC table 232-1)

**Informational Note: Alliant Energy has adopted a Minimum of 20-feet clearance on all DOT crossings.**

- N. The horizontal clearance to buildings, signs etc. where services (at rest) pass but are not attached to the building at this location is 4.5-feet. If the drop meets NESC 230C1 the clearance may be reduced to 2-feet if the building is maintenance free. If the drop is subject to wind movement, then the horizontal clearance is 3.5-feet at blow out position.
- O. Minimum vertical clearance of railroad is 24.5-feet in Wisconsin and 27.5-feet in Iowa. Iowa assumes a railcar height of 23-feet instead of NESC standard of 20 feet.
- P. In order for a meter socket, pedestal or any other metering equipment to be located under decks, porches, balconies or stairs, a minimum vertical clearance of 6.5-feet is required.
- Q. Neutral & secondary conductor up to 300 volts is 10'-6" min. Secondary conductor up to 750 volts is 11' min. Open secondary conductor up to 750 volts is 11'-6" min. and open secondary conductor greater than 750 volts is 13'-6" min.

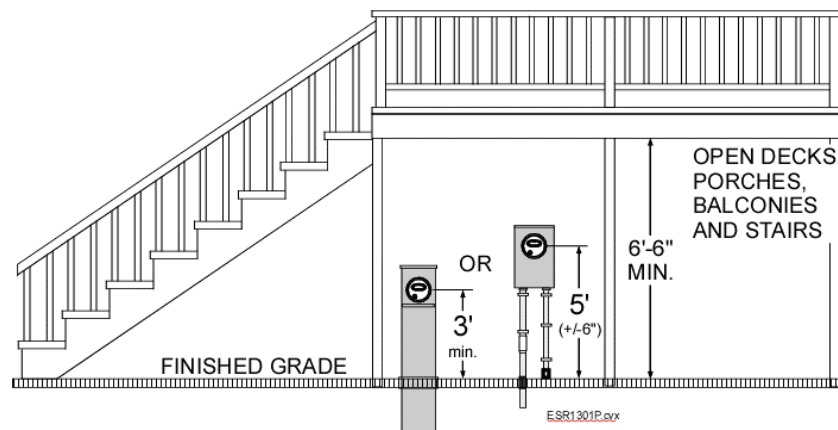

**1302. SERVICE MAST INSTALLATION – ROOF CLEARANCES, CLEARANCE OF SERVICE DROP TERMINATING ON SUPPORT MAST, 300 VOLTS OR LESS**

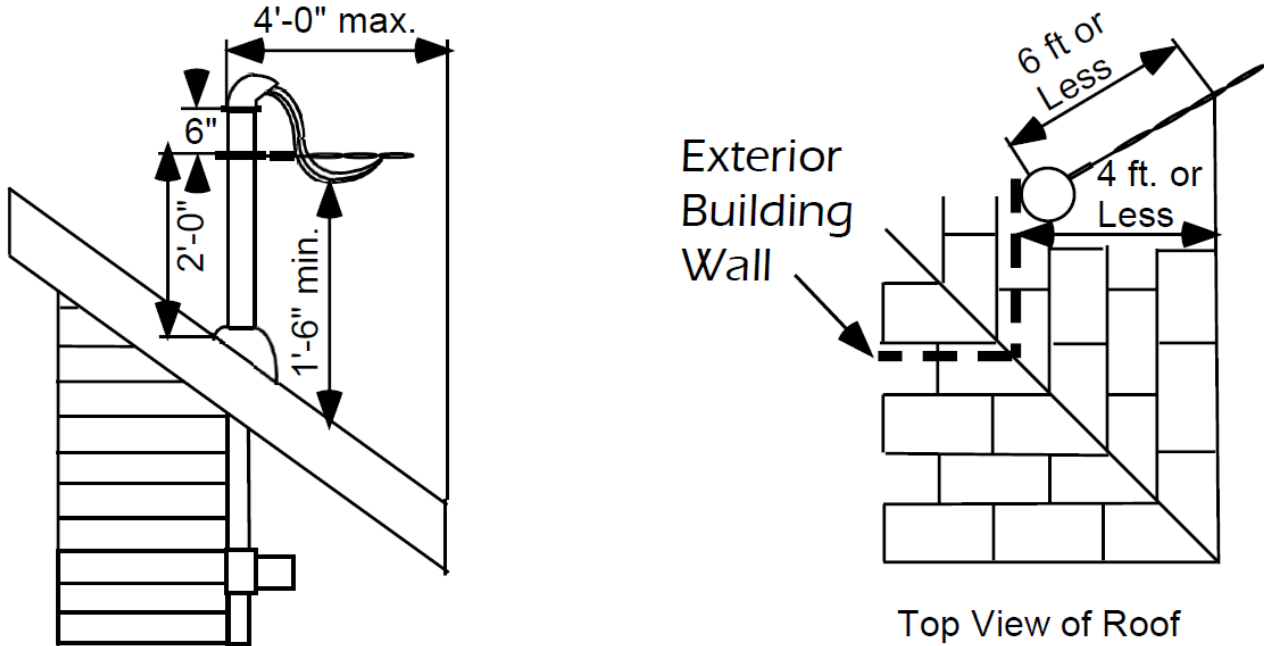

ESR 1302A.cvx

**NOTES:**

1. If 6-feet (4 feet horizontally) or less of service conductor passes over the roof overhang to attach to a service mast through the roof and the service support is located 4-feet or less from the roof edge, the vertical clearance of the service can be reduced to 18".
2. No coupling is allowed in conduit between the weather head and bottom of the soffit.
3. If the roof has a slope of 4/12 or greater and 6 feet or more of the service conductors pass over the roof horizontally, then the minimum clearance allowed is 3 feet.
4. If roof is flat or has a slope less than 4/12 and 6 feet or more of the service conductors pass over the roof or roof overhang, the minimum clearance is 8 feet.
5. 8-foot minimum clearance is required over any roof that is accessible through a doorway, ramp, stairway or permanently mounted ladder.

1302. SERVICE MAST INSTALLATION – ROOF CLEARANCES, CLEARANCE OF SERVICE DROP TERMINATING ON SUPPORT MAST, 300 VOLTS OR LESS - Continued

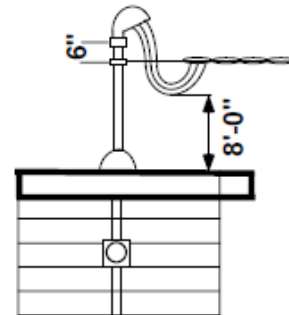
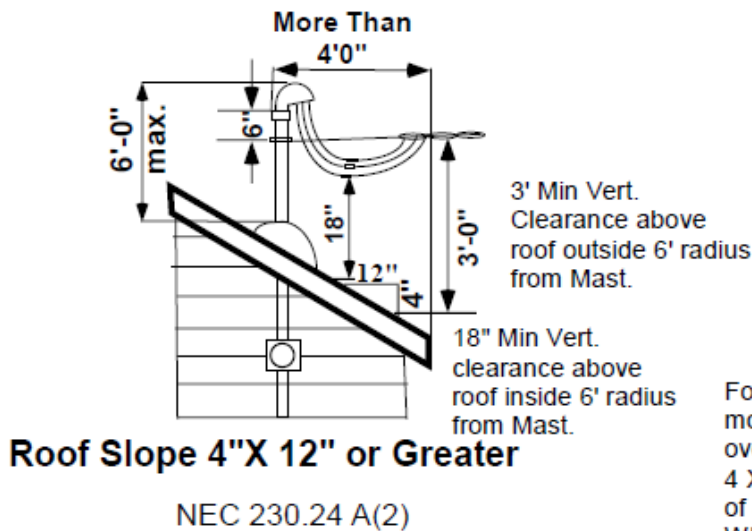
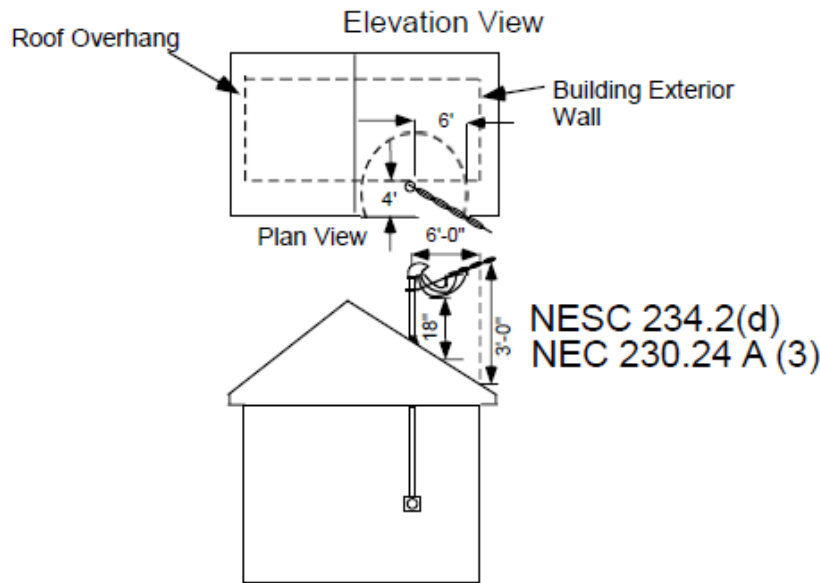

**Flat Roof**

NEC 230.24 A(3)

For service drop crossing more than 6' of flat roof or roof overhang with less than 4 X 12 slope a vertical clearance of 8 ft. is required. Where a service drop crosses less than 6' of overhang the vertical clearance requirement is 18" regardless of roof slope.

ESR 1302B.cvx

**1303. MIN. CLEARANCES FOR SERVICES 300 VOLTS AND BELOW, OVER POOLS**

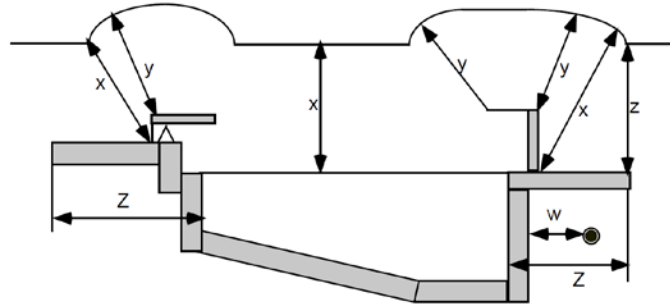

ESR 1303.cnv

	Insulated supply/service cables up to 750V to ground. Supported and cabled with an effectively grounded neutral conductor	All other supply/service drop conductors
<b>X</b> - Clearances in any direction to the water level, edge or water surface, base of diving platform or permanently-anchored raft	<b>22.5'</b>	<b>25'</b>
<b>Y</b> -Clearance in any direction to the diving platform or tower	<b>14.5'</b>	<b>17'</b>

**W**- Clearance from all underground conductors from the outside edge of the pool shall be a minimum of 5 feet.

**Z**- Horizontal limit of clearance measured from the inside wall of the pool shall extend to the outer edge the structure and not less than 10 feet.

**1304. MINIMUM CLEARANCE FOR SERVICES OVER STATE AND FEDERAL HIGHWAYS (DOT Minimum Requirements)**

Alliant Energy has adopted a minimum of 20-foot clearance on all DOT crossings.

**1305. SERVICE CONDUCTOR CLEARANCE FROM SIGNS**

Conductor or Cable	Clearance
Horizontal (displaced by wind)	3.5 ft.
Vertical	3.5 ft.

1306. CLEARANCE ENVELOPE FOR GRAIN BINS FILLED BY PORTABLE AUGERS, CONVEYORS AND ELEVATORS

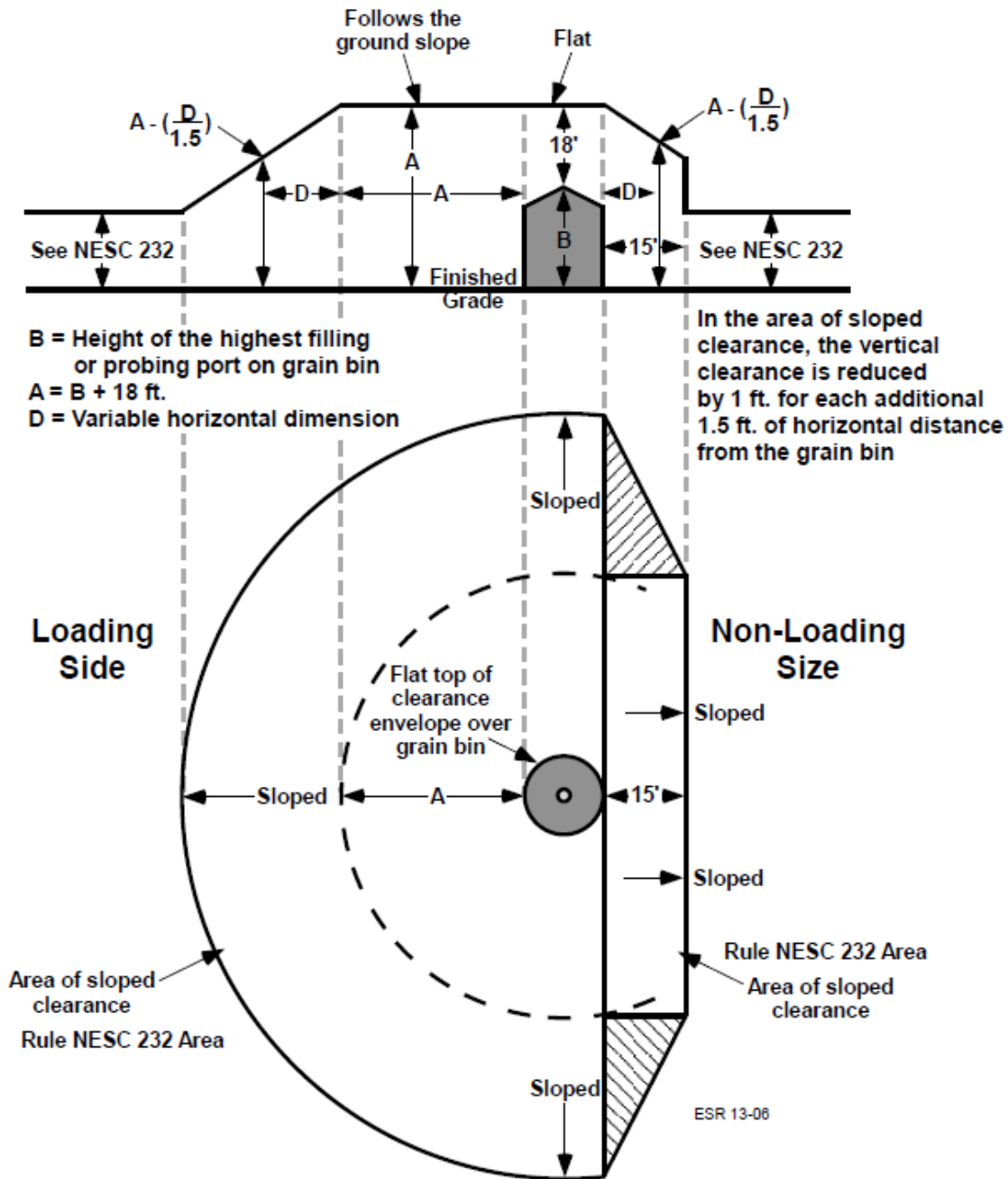

ESR 1306.cvx

NOTE:

18 feet of clearance must be maintained in all directions from probe port. (NESC Rule 234)

1307. SPECIAL HORIZONTAL CLEARANCES FOR OVERHEAD CABLE SERVICES

A. Above-ground Flammable Liquid Storage Tanks and LP Gas Storage Tanks

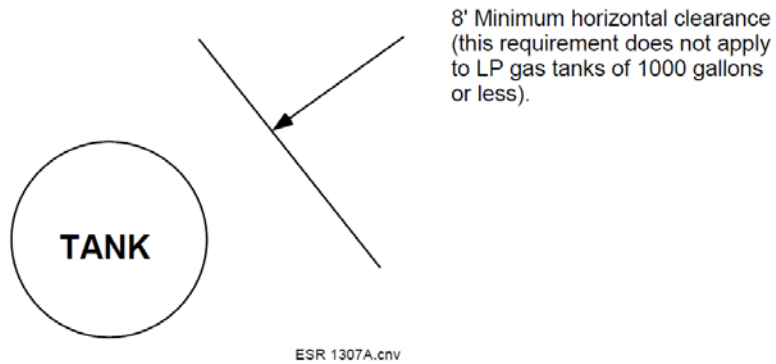

B. Gasoline Dispensing and Service Stations

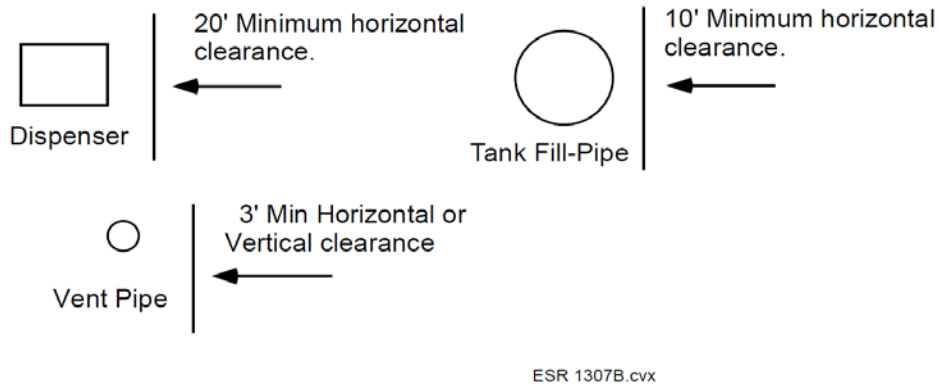

C. Wells

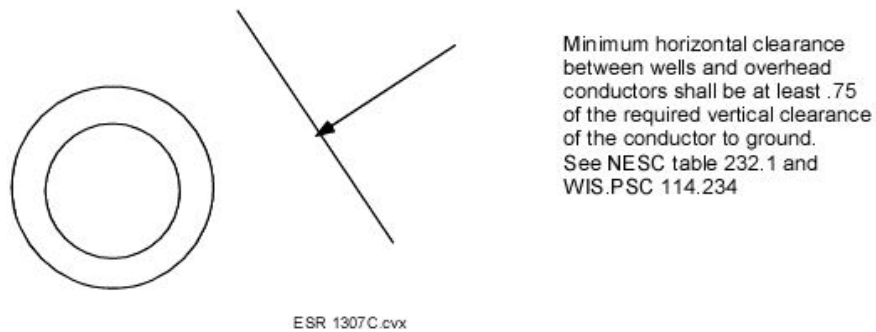

Note: Clearances apply to service lines, metering equipment and other potential sources of ignition.

**D. Antennas (Wisconsin Only)**

Antenna System Support – Poles used for electric power or for communication lines may not be used for supporting or for guying antenna systems.

Setbacks – No wires, cables, or guy wires shall extend over any street or other public thoroughfare or over any electric power or communication lines.

**E. Legally required standby systems (Wisconsin Only)**

The enclosure of the alternate source of power located outdoors for legally required standby systems shall be located at least 10 feet horizontally from any combustible portion of a Type III, Type IV, or Type V building and at least 20 feet from an outdoor electrical transformer, electrical metering, service equipment or normal power distribution equipment.

**NOTE:**

These dimensions may be reduced where a noncombustible barrier is installed that extends at least 3 feet beyond each side of the alternate power source and transformer. The height of the barrier shall be at least one foot above the top of the transformer, electrical metering, service equipment or alternate power source, whichever is higher.

**F. Emergency Systems (Wisconsin Only)**

The enclosure for emergency systems shall be located at least 20 feet from an outdoor electrical transformer, electrical metering, service equipment or normal power distribution equipment.

These dimensions may be reduced where a noncombustible barrier is installed that extends at least 3 feet beyond each side of the alternate power source and transformer. The height of the barrier shall be at least one foot above the top of the transformer, electrical metering, service equipment, or alternate power source, whichever is higher.



**1308. PAD-MOUNT TRANSFORMER LOCATIONS**

- Alliant Energy shall approve the location of all transformer pads.
- Transformer pad locations shall be in accordance with the requirements of *NEC*, *NESC*, National Fire Protection Association (*NFPA*), Environmental Protection Agency (*EPA*) and any state or local requirements.
- Pad-mounted transformers are to be located far enough from the building overhang so they will not be subject to damage by falling snow and ice.
- Pad-mounted transformer locations shall be graded for proper drainage and be readily accessible by truck or other means for change-out.
- Where danger of snow plowing or traffic damage exists, barriers consisting of concrete filled pipe shall be provided for protection.
- Strict adherence to clearance requirements is required in all cases.

**A. Clearance to Fuel Equipment**

1. Transformers shall have a minimum separation of 5-feet from gas service equipment.
2. A minimum separation of 5-feet shall be maintained between transformers and liquid petroleum facilities on site, but not filled on site.
3. If the liquid petroleum facilities are filled on site, the minimum separation is 10-feet.

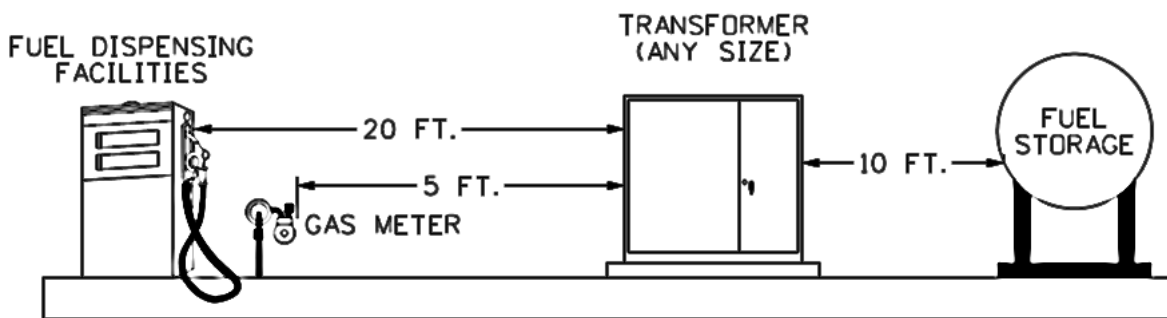

ESR 1308A.dgn

**B. PAD-MOUNT TRANSFORMER LOCATION MAP**

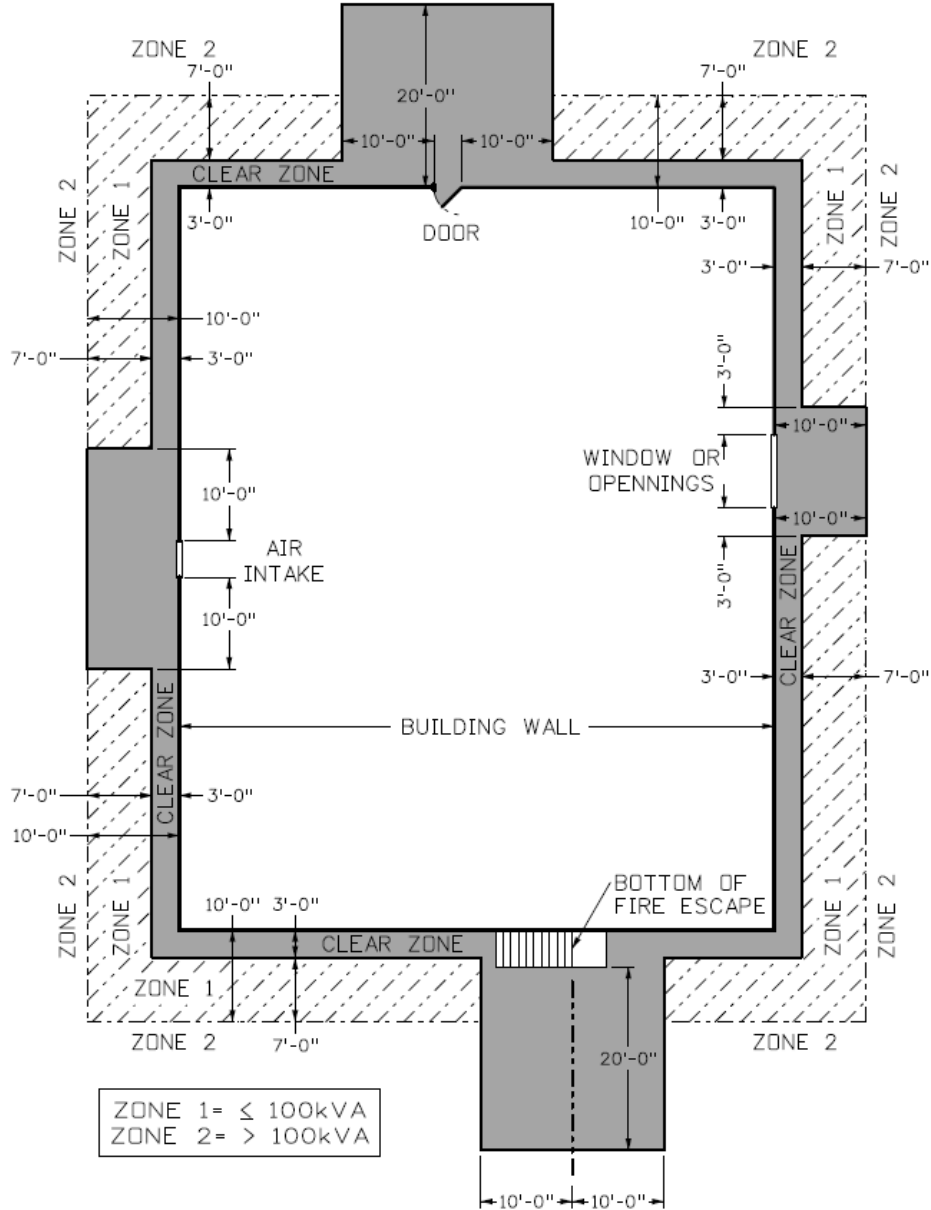

ESR1308B.dgn

**Notes:**

**Clear Zone:** (Grey Area) = No transformers shall be located in this zone

**Zone 1:** (Shaded Area) = Minimum distance for pad-mounted transformers up to 100 kVA from a combustible wall. Also, minimum distance for any pad-mounted transformer from a non-combustible wall.

**Zone 2:** Minimum distance for pad-mounted transformers greater than 100 kVA from a combustible building

An oil-collecting sump shall be installed for transformers over 500kVA if the immediate terrain is pitched toward the wall.

**C. Non-Combustible Building Walls**

A non-combustible wall is one that will not ignite, burn or support combustion when subject to fire or heat. Non-combustible walls are made of non-combustible materials, such as Portland cement concrete, full size brick or stone, hollow concrete block or steel.

**Metal skinned** wood framed buildings are considered to be combustible.

A non-combustible wall shall have not less than a 3 hour fire-resistance rating with all openings in the wall protected with 3 hour rated fire door assemblies. Reference Wisconsin’s State Electrical Code SPS 316.

Pad-Mount oil insulated transformers shall be located a minimum of 3-feet away from non-combustible walls. The following clearances shall also be maintained from doors, windows and other openings:

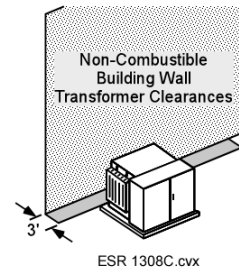

**1. Doors:**

Pad-Mount oil insulated transformers shall not be located within a zone extending 20-feet outward and 10-feet to either side of the building door.

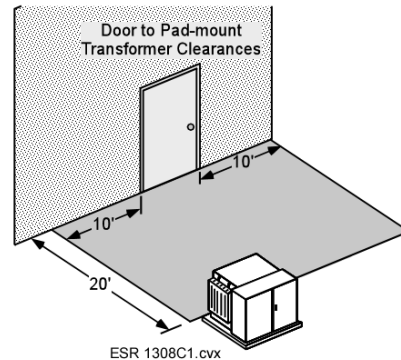

**2. Windows or Openings Other than Air Intake:**

- a) Pad-Mount oil insulated transformers shall not be located within a zone extending 10-feet outward and 3-feet to either side of a window or opening other than an air intake.
- b) Pad-Mount oil insulated transformers shall not be located less than 5-feet from any part of a second story window or opening other than an air intake.

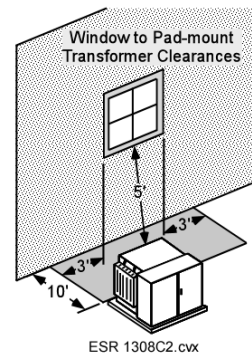

**3. Air-Intake Openings:**

Pad-Mount oil insulated transformers shall not be located within a zone extending 10 feet outward and 10 feet to either side of an air intake opening. Transformers may be located within the zone beneath an air intake opening provided there is a minimum 25 feet diagonal separation between the transformer and the opening.

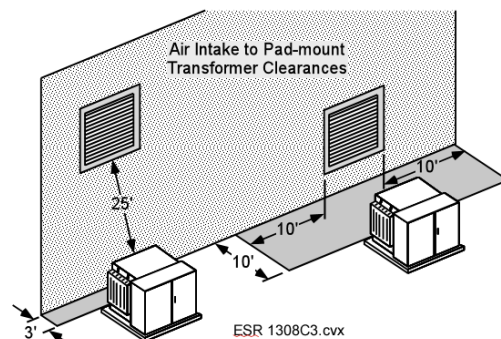

**D. Combustible Building Walls**

1. Pad-mount oil insulated transformers in sizes up to and including 100 kVA shall be located according to the provisions set forth in the Non-Combustible Buildings Walls - Section C.
2. Transformers greater than 100 kVA shall be located a minimum of 10-feet from a combustible wall. Also, the clearances from building doors, windows and other openings set forth for non-combustible walls shall be maintained.
3. An oil-collecting sump shall be installed for transformers in sizes exceeding 500 kVA if the immediate terrain is pitched toward the building.

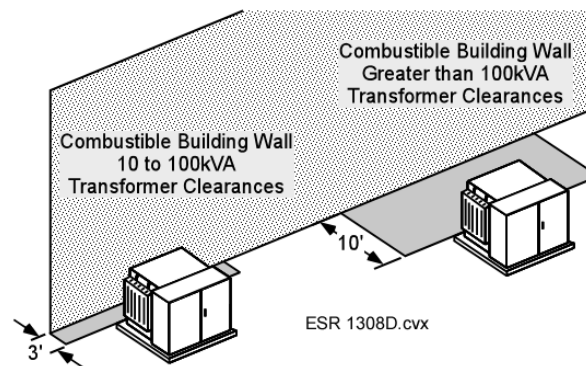

**E. Fire Escapes**

Pad-mount oil insulated transformers shall be located such that a minimum outward clearance of 20-feet and a minimum clearance of 10-feet to either side of the point where the fire escape touches the ground shall be maintained at all times. If the pad-mount transformer is located under the fire escape, a vertical clearance of 10-feet shall be maintained.

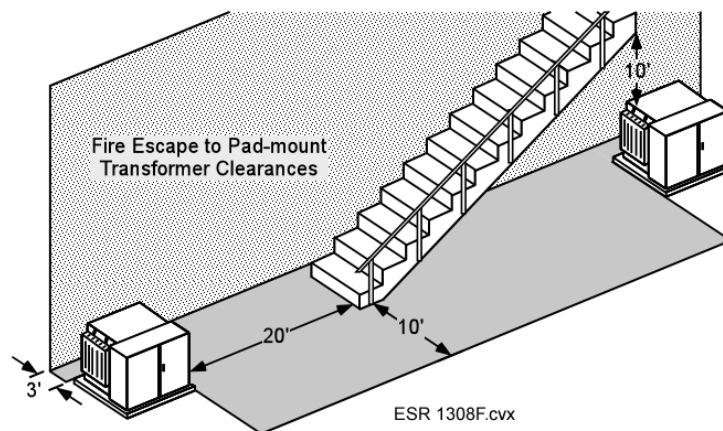

1309. SINGLE-PHASE, PAD-MOUNT TRANSFORMER PROTECTION AND METERING EQUIPMENT

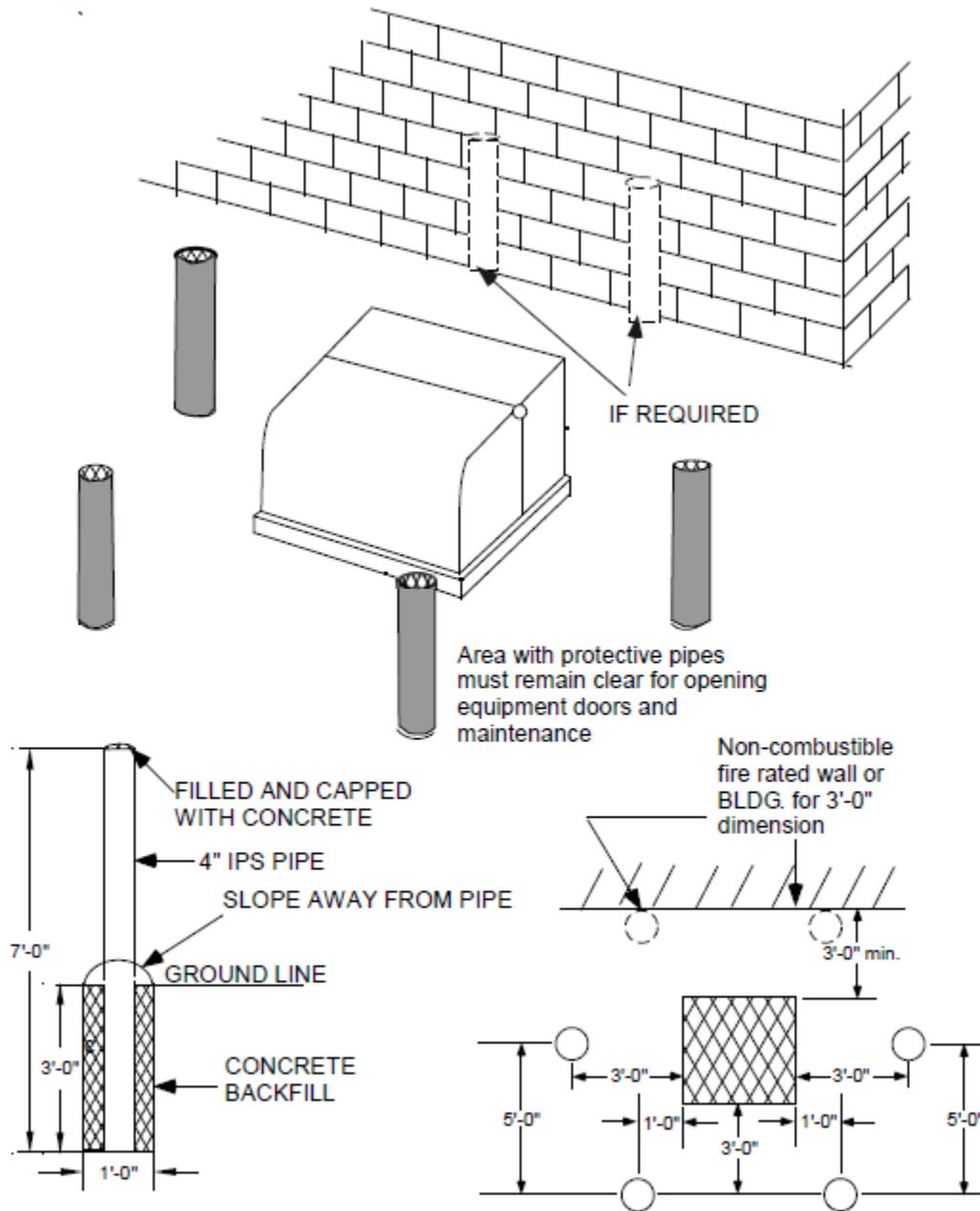

ESR 1309.cvx

Transformer protection required as requested by Alliant Energy.  
Horizontal Barriers between posts are not allowed without Alliant Energy approval.

**1310. THREE-PHASE, PAD-MOUNT TRANSFORMER PROTECTION AND METERING EQUIPMENT**

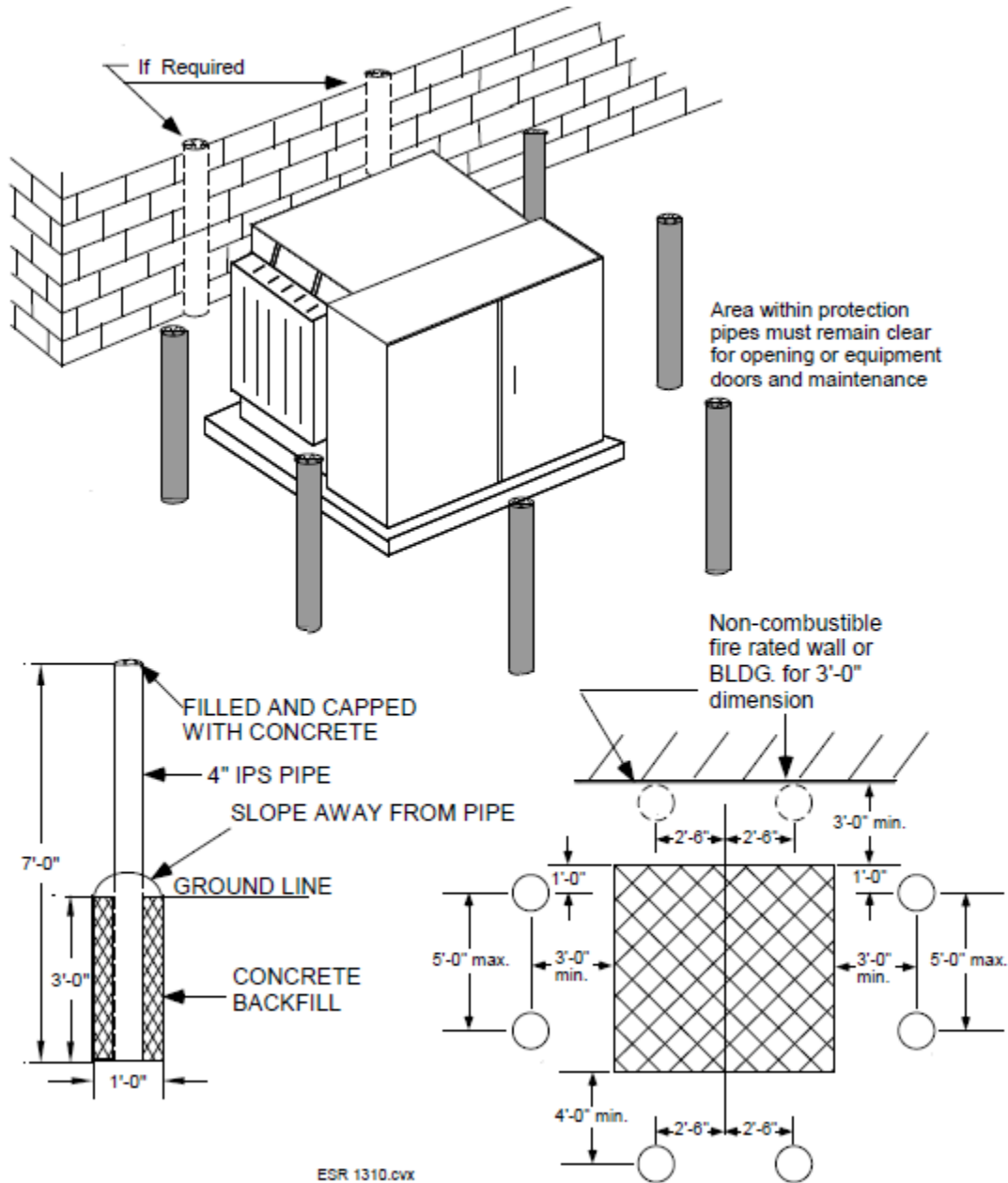

Transformer protection required as requested by Alliant Energy.  
Horizontal Barriers between posts are not allowed without Alliant Energy approval.

CLEARANCES

1311. BARRIERS

If the clearances specified previously cannot be obtained, a fire resistant barrier may be constructed in lieu of the separation. The following methods of construction are acceptable.

- A. Non-combustible walls – The barrier shall extend to a projection line from the corner of the pad-mount to the farthest corner of the window, door or opening in question. The height of the barrier shall be 1 foot above the top of the pad-mount transformer.

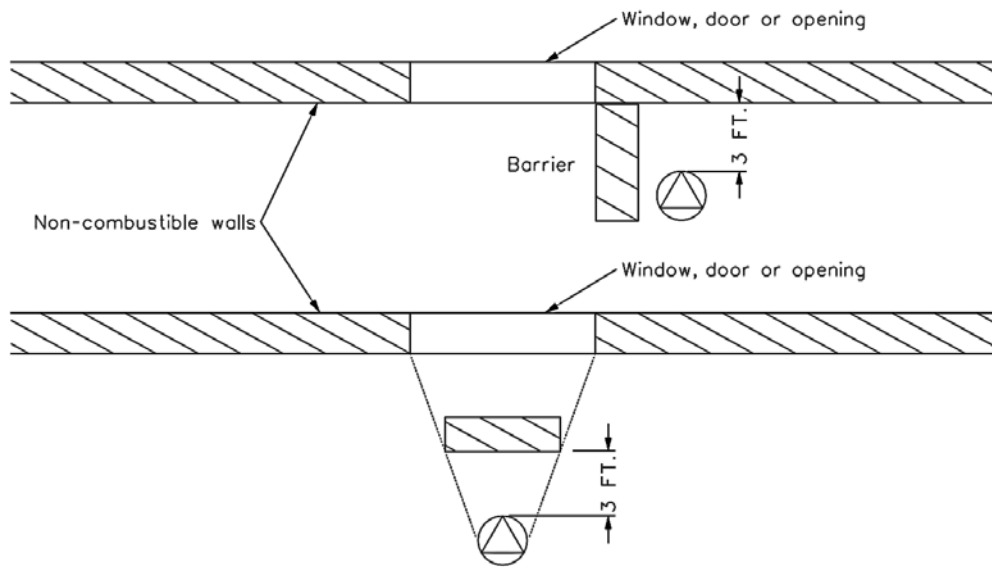

ESR 1311A.dgn

- B. Combustible walls – The barrier shall extend 3-feet beyond each side of the pad-mount transformer. The height of the barrier shall be 1-foot above the top of the pad-mount transformer.

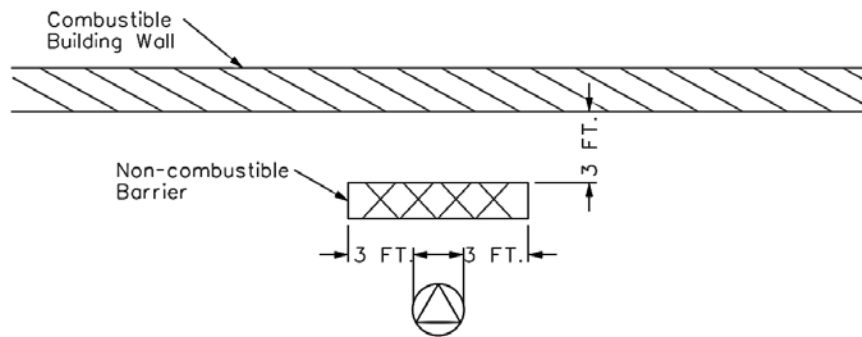

ESR 1311B.dgn

- C. A barrier is not an acceptable solution to Air-Intake opening clearance requirements.



**1312. RECREATIONAL VEHICLES (RV's), MOBILE HOMES, MANUFACTURED HOMES AND PARK TRAILER CLEARANCES**

RV and mobile home parks shall conform to *NEC* 550, 551 and 552 as required by code in addition to state and local laws.

**A. Recreational Vehicles:**

Open conductors 1000 volts and less, nominal, shall have a minimum vertical clearance of 18ft and a minimum horizontal clearance of 3ft in all areas subject to recreational vehicle movement. See *NEC* 551.79 Clearance for Overhead Conductors.

**B. All other Areas:**

Clearances shall conform to the *NEC* and/or the rest of this chapter.

**1313. SOLAR PANEL CLEARANCE REQUIREMENT**

A minimum vertical clearance of 10.5-feet is required from any Alliant Energy secondary or service conductors that cross over any building or structure containing solar panels. Additional clearances are required based on the type of conductor spanning over the location of the proposed solar panel installation. Distances are measured from conductor to closest structure (solar panel or roof).

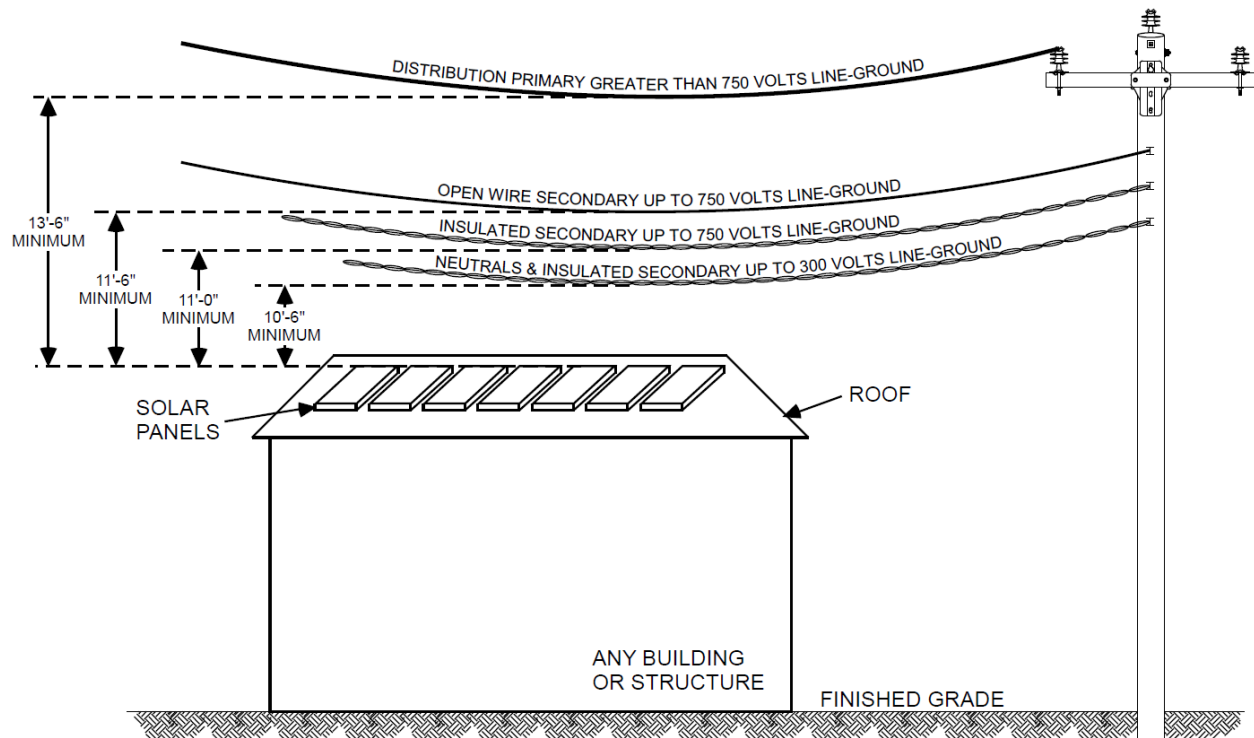



Alliant Energy

# Chapter 14

Electric Service Rules

**RESERVED FOR NOTES:**



## ELECTRIC SERVICE RULES

GROUNDING

Issued Jan 2024

# CHAPTER 14

## ELECTRIC SERVICE RULES – GROUNDING & BONDING

---

### 1400. SCOPE

This chapter contains the typical grounding and bonding requirements for service types listed within this e-manual. Not all grounding and bonding situations are covered in this chapter. It is the responsibility of the customer and the Authority Having Jurisdiction (AHJ) to verify all *NEC* and other applicable code grounding requirements are met.

### 1401. GENERAL

- A. The grounding of electric installations is essential for the safety of those using the electric service, personnel maintaining the service, and is a safeguard for the customer's equipment.
- B. The grounding electrode conductor (GEC).
  - 1. The grounding electrode conductor shall not be routed through meter sockets, metering transformer cabinets, or a metering pedestal without a service disconnect.
  - 2. The grounding electrode conductor may be terminated in one of the following:
    - a) In the service disconnect(s)
    - b) In the metering equipment containing a service disconnect
    - c) In the termination compartment of multiple metering installations
- C. Metal underground gas piping systems on the line side of the gas meter shall not be used as a grounding electrode or be bonded to the grounding electrode system.
- D. If two ground rods are installed, both ground rods shall be installed to the left or to the right of meter socket but not in front. The grounding electrode conductor shall not pass in front of meter-socket or pedestal.
- E. For all 3-Phase, 4-Wire services, the customer's grounded (neutral) conductor shall be terminated on the first service disconnect or series of service disconnects (6 switch rule) reference (NEC 250.24(C)).

GROUNDING - WALL MOUNTED METER SOCKET

Fig. 1402A

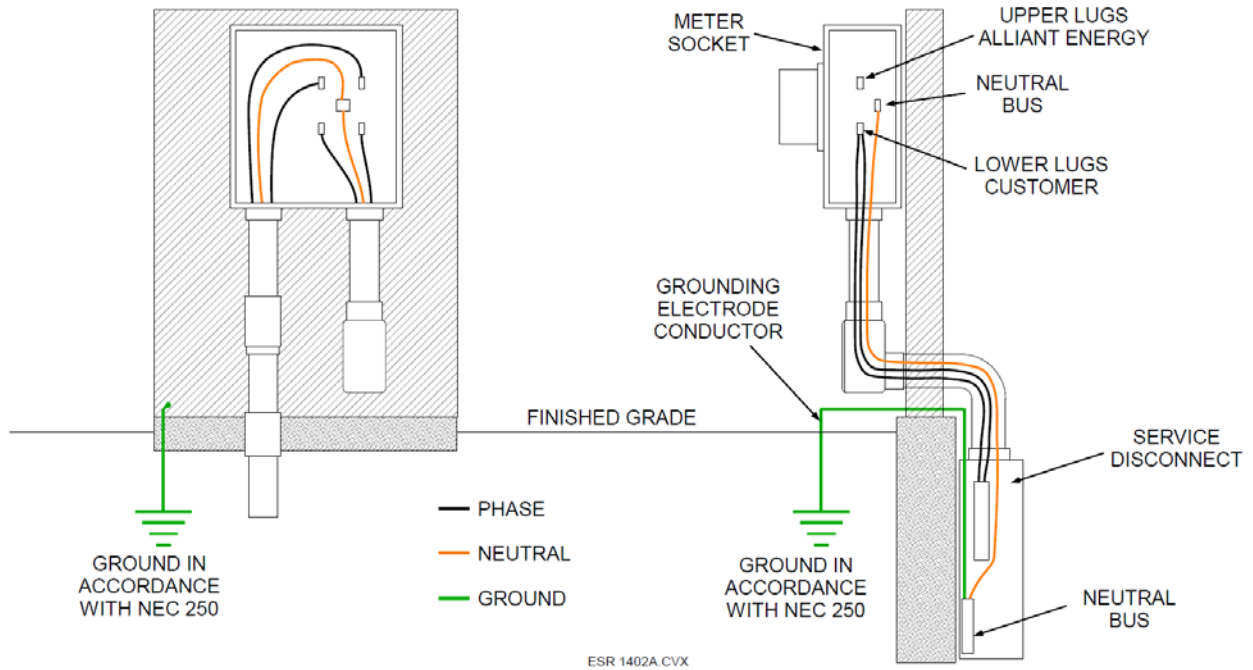

GROUNDING - WALL MOUNTED SOCKET PEDESTAL

Fig. 1402B

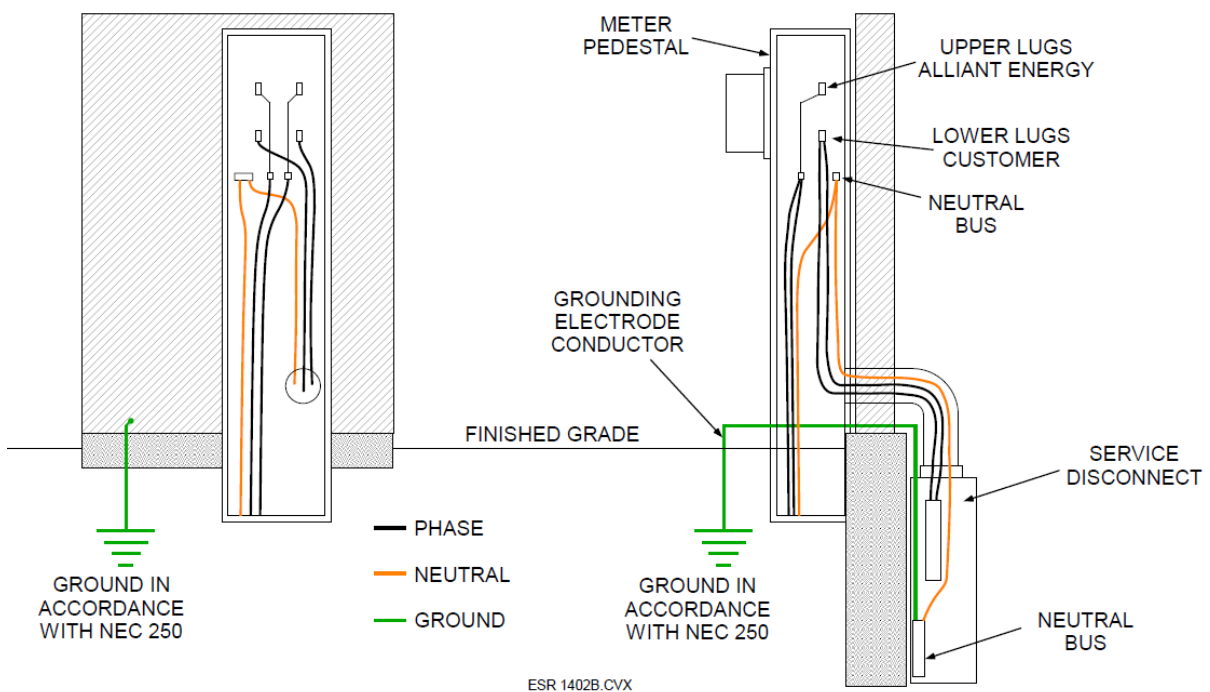

GROUNDING - FREE STANDING PEDESTALS WITH BREAKER (MAIN)

Fig 1402C

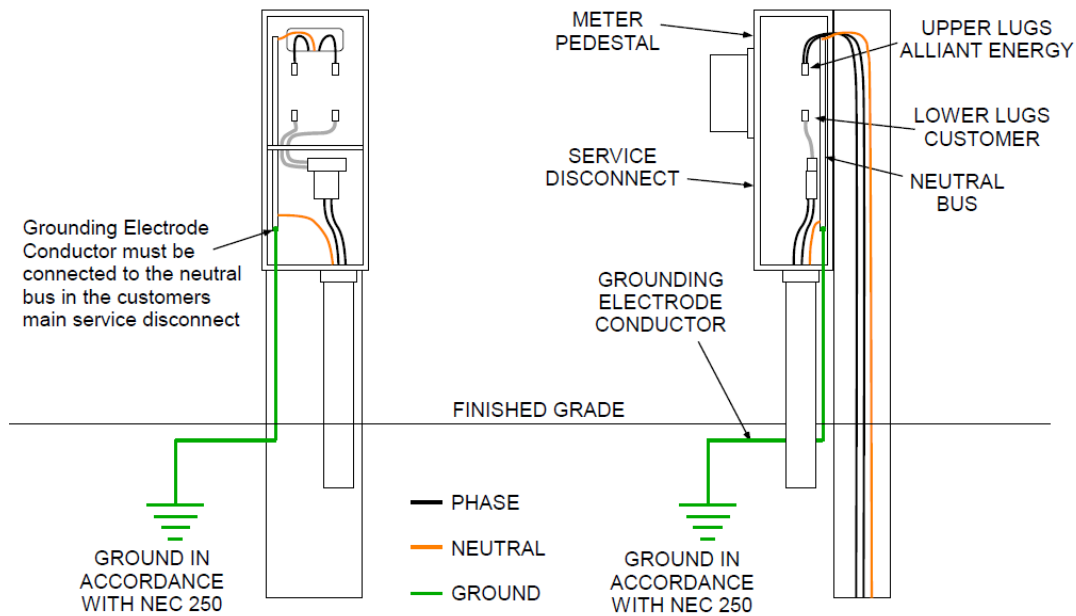

ESR 1402C.CVX

GROUNDING - FARM SERVICE YARD POLES

Fig. 1402D

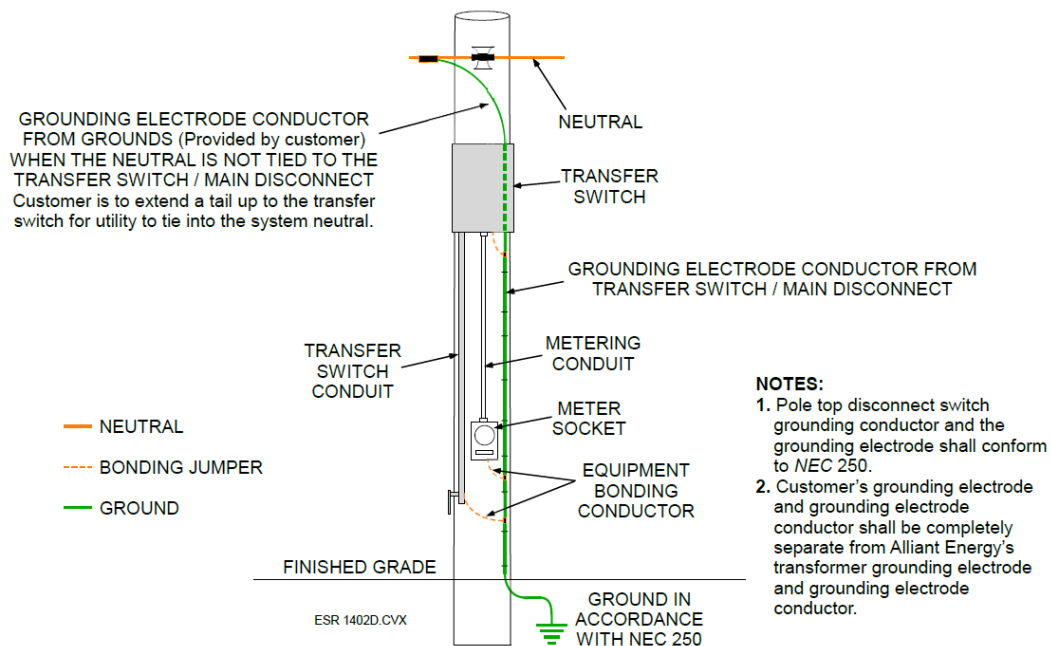

NOTES:

1. Pole top disconnect switch grounding conductor and the grounding electrode shall conform to NEC 250.
2. Customer's grounding electrode and grounding electrode conductor shall be completely separate from Alliant Energy's transformer grounding electrode and grounding electrode conductor.

ESR 1402D.CVX

GROUNDING - MULTIMETERING (2-6 METERS)

Fig. 1402E

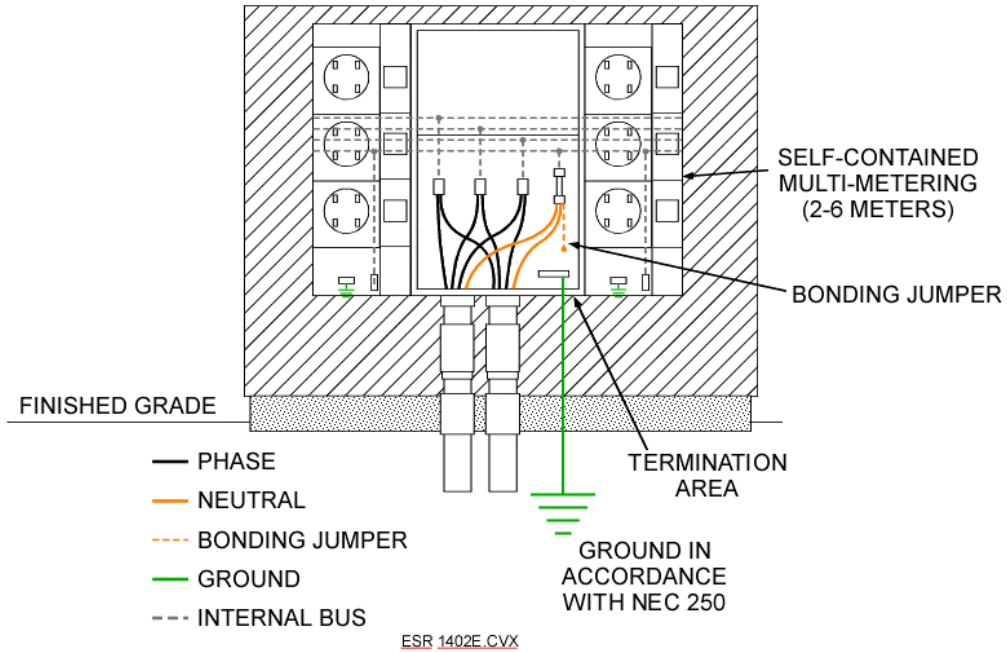

GROUNDING - METERING TRANSFORMER CABINET

Fig. 1402F

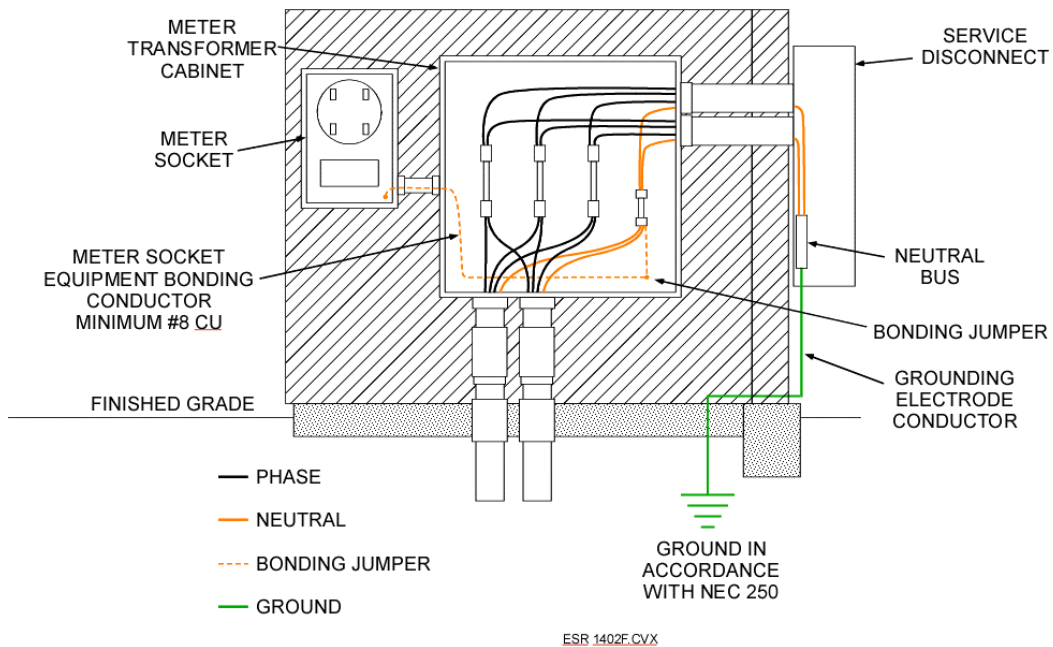

**GROUNDING - TERMINATION CABINET W/MAIN, METERING TRANSFORMER CABINET, MULTIMETERING**

Fig. 1402G1

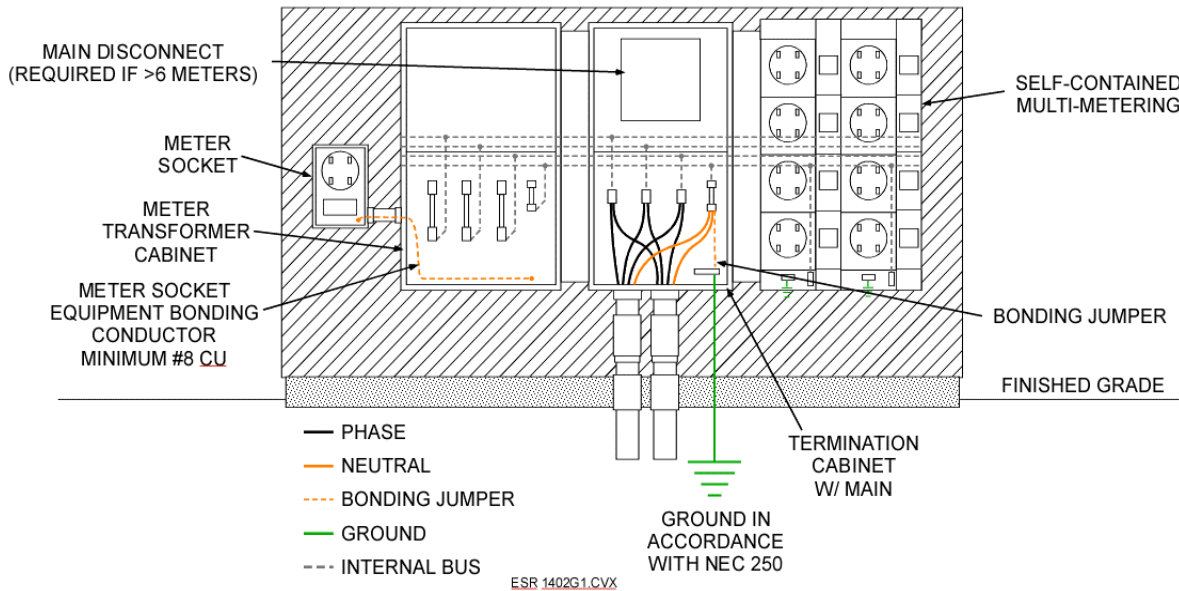

**GROUNDING - TERMINATION CABINET WITHOUT MAIN, METERING TRANSFORMER CABINET, MULTIMETERING**

Fig. 1402G2

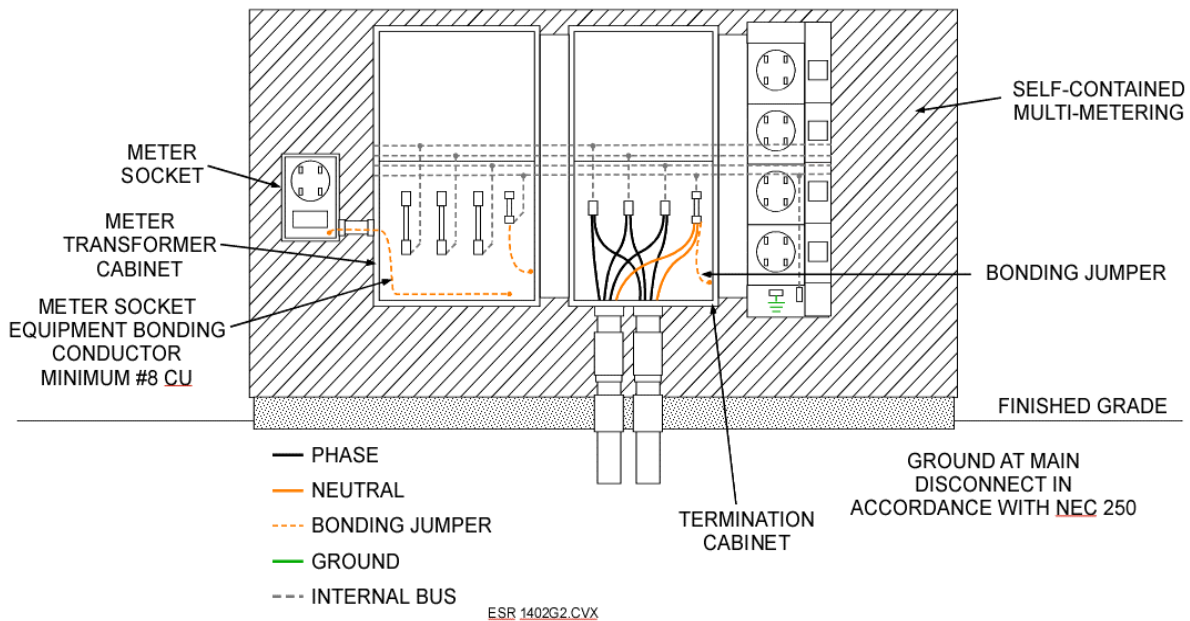

**1402. BONDING SERVICE ENTRANCE AND METERING EQUIPMENT**

- A. The electrical contractor is responsible for all bonding connections.
- B. The termination cabinet, the metering transformer cabinet and the meter socket enclosure shall be bonded to:
  - 1. The system neutral when they are located on the line side of or at the main disconnect.
  - 2. The equipment grounding conductor, when all of the following apply:
    - a) They are installed on the load side of the main disconnect
    - b) No service ground-fault protection is installed
    - c) They are located immediately adjacent to the main disconnect
- C. Bonding shall be provided where necessary to ensure electrical continuity and have the capacity to safely conduct any fault current likely to be imposed on it.
- D. Intersystem bonding – CATV, satellite dish systems and telephone companies shall bond to the grounding electrode system, if available. If the grounding electrode system is not readily available, bonding shall be done at the ground terminal bar in the main service entrance equipment (*NEC* 250.94 (2) or (3) only). The intersystem bonding shall not be done in or on the metering equipment, refer to Wisconsin PSC 114.099.
- E. Meter disconnect switches nominally rated not in excess of 600 volts shall have a short circuit rating equal to or greater than the available short circuit current. These devices shall also be grounded and bonded according to parts V and VII of *NEC* 250.

**ELECTRIC SERVICE RULES**

**GROUNDING**

Issued Jan 2024

**1403. BONDING CONDUCTOR SIZING**

- A. Equipment bonding conductors on the supply side of service shall be sized according to *NEC* 250.102C. ESR e-manual Table 1403 shall be used as a guide in determining the minimum size for equipment bonding conductors for metering cabinet installations.
- B. ESR e-manual table 1403 assumes 75°C temperature ratings for service entrance conductors, with no adjustment factor for more than three current-carrying conductors. On a 3-phase 4-wire wye service where the major portion of the load consists of nonlinear (harmonic) loads, the neutral shall be considered as a “current-carrying” conductor (*NEC* 310.15(B)(5)(c)); in such cases, a larger equipment-bonding conductor shall be used.

**Aluminum Bonding Conductor Table**

Metering Cabinet Rating	Service Entrance Conductor Size 75°C	kcmil	NEC Table 310.15(B)(16) 75°C Ampacity (per run)	Number of Runs	Total Ampacity	Service Entrance Conductor Total Area	Bonding Conductor Area	Minimum Equipment Bonding Conductor Size or Equivalent Area for Parallel Conductors	
Amps	AL	kcmil	Amps, per run	Runs	Amps	kcmil	kcmil	AL, AWG/kcmil	Cu, AWG/kcmil
Notes:		(5)	(4) (6)					(1)* (2)**	(3)
400	250	250	205	2	410	500	63	** 1/0	#2
	350	350	250	2	500	700	88	** 3/0	1/0
600	250	250	205	3	615	750	94	** 3/0	1/0
	350	350	250	3	750	1050	131	** 4/0	2/0
800	250	250	205	4	820	1000	125	** 4/0	2/0
	350	350	250	4	1000	1400	175	** 4/0	2/0
1200	350	350	250	5	1250	1750	219	** 4/0	2/0
	500	500	310	4	1240	2000	250	* 250	3/0
	600	600	340	4	1360	2400	300	* 350	4/0
1600	350	350	250	7	1750	2450	306	* 350	4/0
	500	500	310	6	1860	3000	375	* 400	250
	600	600	340	5	1700	3000	375	* 400	250
2000	350	350	250	8	2000	2800	350	* 350	4/0
	500	500	310	7	2170	3500	438	* 600	350
	600	600	340	6	2040	3600	450	* 600	350
2500	750	750	385	7	2695	5250	656	* 750	500
	1000	1000	445	6	2670	6000	750	* 750	500
3000	750	750	385	8	3080	6000	750	* 750	500
	1000	1000	445	7	3115	7000	875	* 1200	700

**NOTES:**

- (1) NEC 250.102(C)(1) Size - Supply-Side Bonding Jumper - 12.5%
- (2) NEC Table 250.66, up to 1750 kcmil
- (3) NEC Table 250.122, Equivalent Copper to Aluminum
- (4) NEC Table 310.15(B)(16) 75°C Ampacity
- (5) NEC Chapter 9, Table 8, Conductor Properties
- (6) NEC 310.15(B)(5)(a) Neutral Conductor Not Considered a "Current-Carrying" Conductor





Copper Bonding Conductor Table

Metering Cabinet Rating	Service Entrance Conductor Size 75°C	kcmil	NEC Table 310.15(B)(16) 75°C Ampacity (per run)	Number of Runs	Total Ampacity	Service Entrance Conductor Total Area	Bonding Conductor Area	Minimum Equipment Bonding Conductor Size or Equivalent Area for Parallel Conductors	
Amps	CU	kcmil	Amps, per run	Runs	Amps	kcmil	kcmil	CU, AWG/kcmil	AL, AWG/kcmil
Notes:		(5)	(4) (6)					(1)* (2)**	(3)
400	3/0	168	200	2	400	336		** #2	1/0
	4/0	212	230	2	460	454		** 1/0	3/0
	600	600	420	1	420	600		** 1/0	3/0
600	3/0	168	200	3	600	504		** 1/0	3/0
	4/0	212	230	3	690	636		** 2/0	4/0
	350	350	310	2	620	700		** 2/0	4/0
800	350	350	310	3	930	1050		** 2/0	4/0
	500	500	380	3	1140	1500	188	* 4/0	350
1200	350	350	310	4	1240	1400	175	* 4/0	350
	500	500	380	4	1520	2000	250	* 250	400
	750	750	475	3	1425	2250	281	* 350	600
1600	350	350	310	6	1860	2100	263	* 350	600
	500	500	380	5	1900	2500	313	* 350	600
	600	600	420	4	1680	2400	300	* 350	600
	750	750	475	4	1900	3000	375	* 400	600
2000	350	350	310	7	2170	2450	306	* 350	500
	500	500	380	6	2280	3000	375	* 400	600
	600	600	420	5	2100	3000	375	* 400	600
	750	750	475	5	2375	3750	469	* 500	750
2500	500	500	380	7	2660	3500	438	* 500	750
	600	600	420	6	2520	3600	450	* 500	750
	750	750	475	6	2850	4500	563	* 700	1200
3000	500	500	380	8	3040	4000	500	* 500	750
	600	600	420	8	3360	4800	600	* 700	1200
	750	750	475	7	3325	5250	656	* 700	1200

NOTES:

- (1) NEC 250.102(C)(1) Size - Supply-Side Bonding Jumper - 12.5%
- (2) NEC Table 250.66, up to 1100 kcmil
- (3) NEC Table 250.122, Equivalent Copper to Aluminum
- (4) NEC Table 310.15(B)(16) 75°C Ampacity
- (5) NEC Chapter 9, Table 8, Conductor Properties
- (6) NEC 310.15(B)(5)(a) Neutral Conductor Not Considered a "Current-Carrying" Conductor

Alliant Energy

# Chapter 15

Electric Service Rules

**RESERVED FOR NOTES:**



## CHAPTER 15

### ELECTRIC SERVICE RULES – ELECTRIC VEHICLES

---

#### 1500. SCOPE

This chapter covers Electric Vehicle (EV) charging and public charging stations. All sections of the Electric Service Rule e-manual apply in addition to NEC 625 and all applicable local and federal electrical, building and fire codes.

For more information call the Alliant Energy Customer Service: 1-800-255-4268 or visit our website: [www.alliantenergy.com/electricvehicles](http://www.alliantenergy.com/electricvehicles)

#### 1501. ELECTRIC VEHICLE (EV) CHARGING

If considering installing an Electric Vehicle Charging Station, please work with a licensed electrical contractor to understand the costs involved. In many cases, a customer may wire from their existing service panel and a second meter is not required. A customer installing an Electric Vehicle Charging Station may keep their current rate or consider the Time-of-Use Rate.

For more information on rates call Alliant Energy at 1-800-ALLIANT (255-4268) or visit our website: [www.alliantenergy.com/electricvehicles](http://www.alliantenergy.com/electricvehicles)

#### 1502. ELECTRIC VEHICLE (EV) CHARGING - SERVICE CAPACITY

##### A. Existing Service - Adequate Service Capacity

##### 1. Level I EV Charging (120V):

A dedicated circuit and standard outlet are needed. A second meter is not required. Customer should verify with a licensed electrician if the existing wiring is sufficient to accommodate a Level I EV Charging Station.

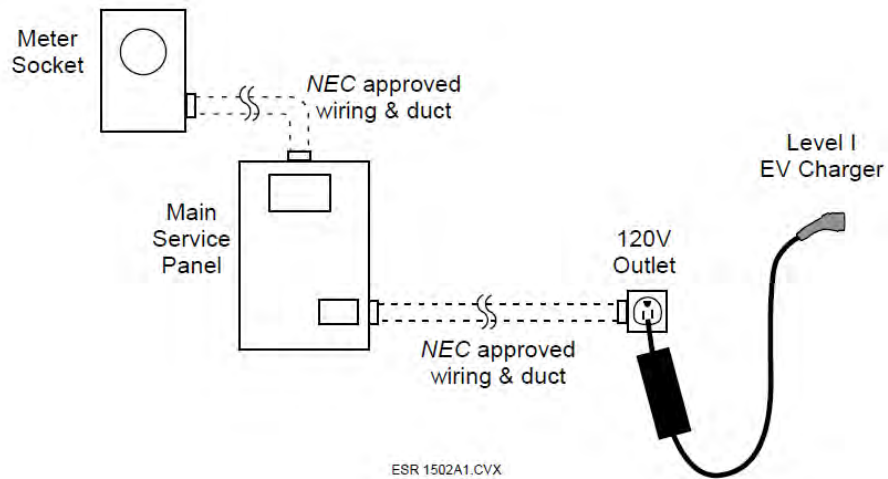

**2. Level II EV Charging (240V residential or 208V commercial):**

A dedicated circuit and outlet with adequate capacity to accommodate a Level II EV Charging Station are needed. Customer should verify with a licensed electrician if the existing wiring, service panel and meter is sufficient to accommodate a Level II EV Charging Station.

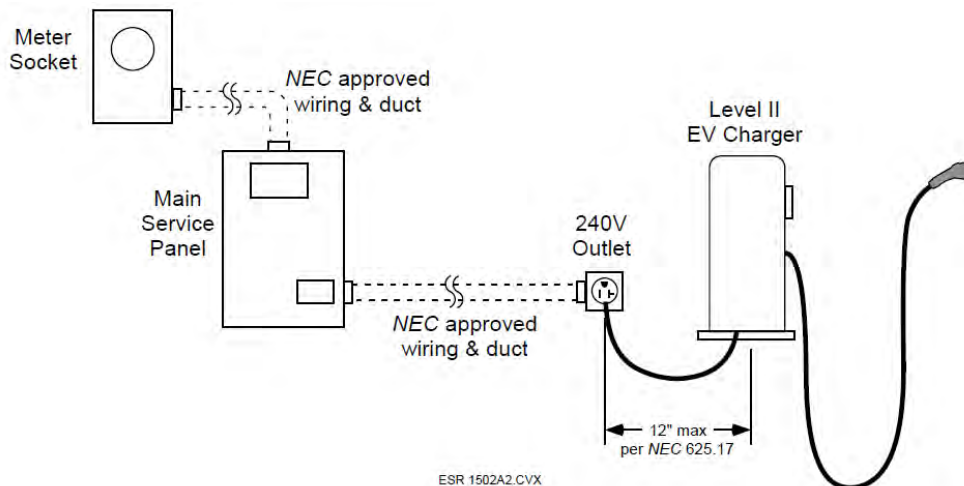

**B. Existing Service - Inadequate Service Capacity**

If the existing electric service is deemed inadequate by a licensed electrician to supply a Level I or Level II EV Charging Station, multiple options exist for the customer. These options include replacing or making upgrades to the panel(s), meter equipment, or installing a duplex meter socket.

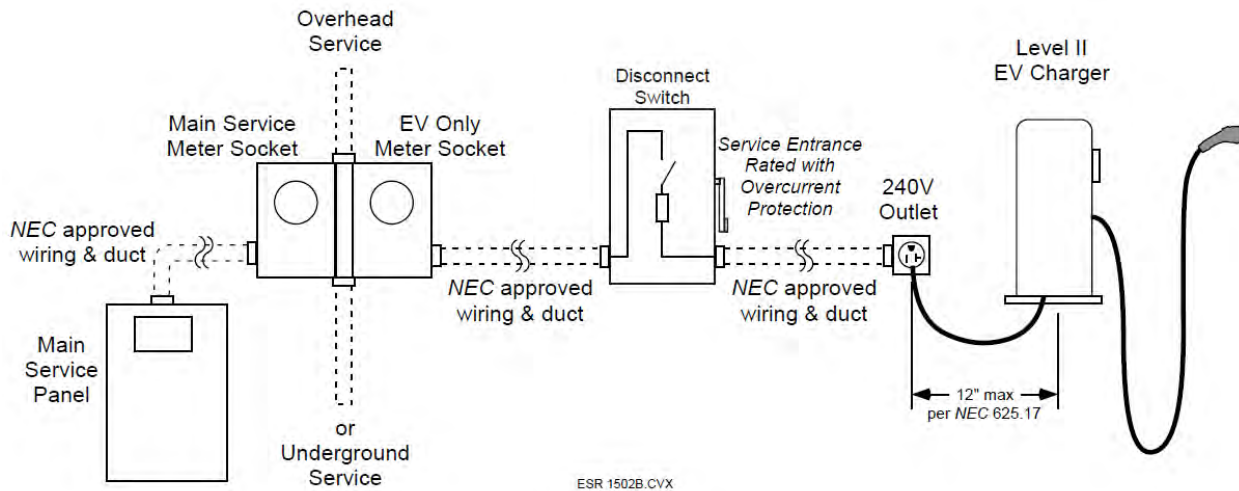

**C. Remote Building or Structure**

1. Remote Building or Structure already has dedicated service

If remote building/structure already has an electrically isolated service, an EV Charging Station may be added based on the previous sections.

2. Remote Building or Structure does not have a dedicated service

A second electric service for an EV Charging Station may be allowed in order to install a Level II EV Charging Station on an unattached garage or remote building/structure as long as the remote building/structure is electrically isolated from any building with an existing electric service. (also see [ESR e-manual 109.C.3](#)).

**1503. Level III DC Fast Charging (DCFC) (480V)**

A customer may install a separate stand-alone EV DCFC Station. The customer shall follow all of the applicable sections of the ESR e-manual to establish a new service point.

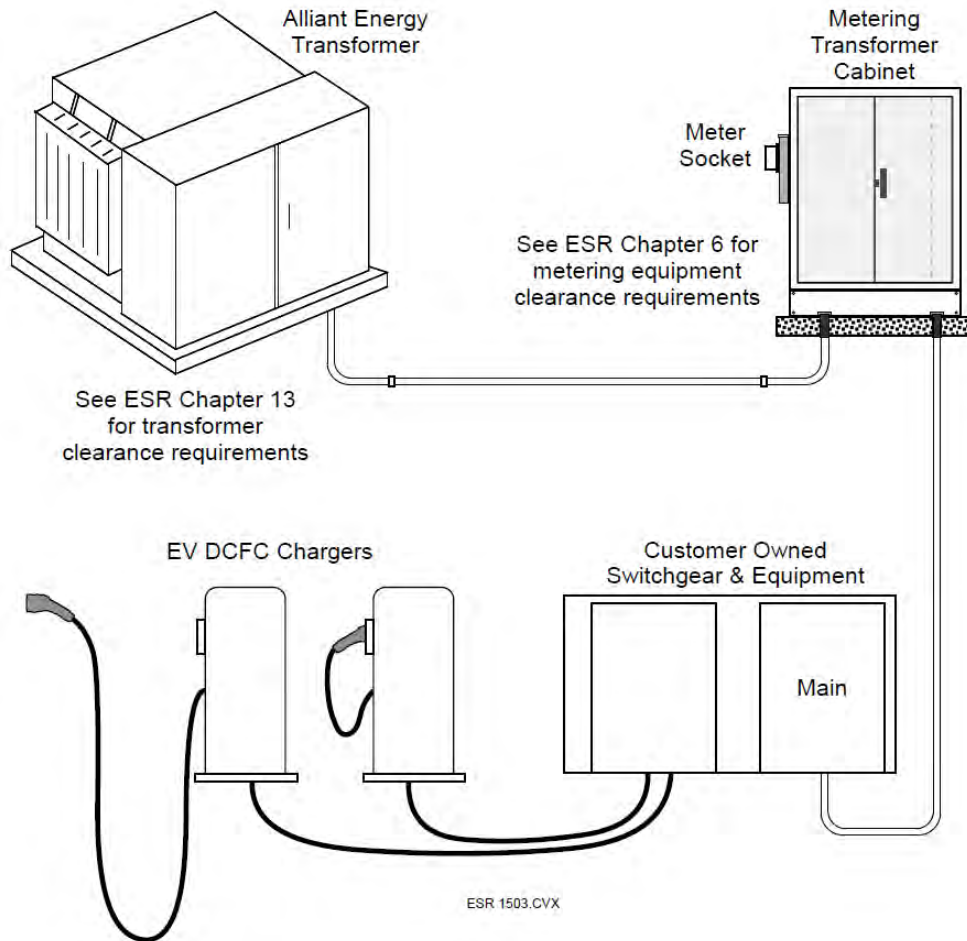



## ELECTRIC SERVICE RULES

**INDEX**

**Issued Jan 2024**

AHJ, 1-2, 1-3, 1-9, 1-12, 14-1	Flood Zone Exception, 6-3
AIC, 1-10	General Information, 1-1
Air Conditioning Systems, 11-13	Grade Level Switch, 5-3, 8-4, 8-15
Application for Service, 1-3	Grain Bins, 13-7
Backup Service, 1-5	Grounding, 14-1 to 14-6
Bonding, 1-15, 8-2, 9-2, 9-4, 14-1, 14-6 to 14-9	Highways, 13-6
Box Pad 1PH, 4-1, 4-19	Holiday Lighting, 9-8
Box Pad 3PH, 4-7, 4-18	HUD Manufactured Homes, 7-1 to 7-11
CATV, 9-1 to 9-6	Identification of Conductors, 1-12
Charges, 1-3	Inspections, 1-3, 1-12
Clearance Requirement, 6-4, 13-1 to 13-17	Irrigation, 6-13, 8-1, 8-10 to 8-15
Codes and Rules, 1-1	Isolated Building, 1-2, 1-6
Communication Tower, 1-2, 1-15	Isolation, 5-3, 5-4, 8-1, 8-16, 8-17, 10-6, 10-8
Compliance, 1-1, 4-2	Line Clearance, 1-3
Conductors, 1-12, 4-1, 4-3, 6-3, 6-18, 12-4	Maintenance, 1-12, 6-5, 6-8, 6-10, 9-2, 9-3, 9-6, 10-3
Distributed Generation, 5-1	Manufactured Home, 7-1
(DG) Availability, 5-1	Mast, 3-1 to 3-4
(DG) Drawings, 5-4	Meter Configurations, 1-14, 6-1 to 6-9
(DG) Technical Information, 5-1	Meter Identification, 6-3
Doors, 13-2, 13-12	Meter Locations, 6-1
Driveway, 2-2, 3-1, 4-2, 6-1, 13-3	Meter Seal, 6-3
Easements, 1-3, 1-12, 10-3	Meter Shield, 6-7
Equipment on Customer Premise, 1-2	Mobile Home Courts, 7-4
Electric Vehicles (EV), 15-1 to 15-3	Mobile Home, 7-1
Farm Service Yard Pole, 8-1	Modular Home, 7-3
Farm Services, 8-1	Motor Specs, 11-2
Fault Current, 1-10, 1-11, 6-1, 6-13	Municipal, 9-1 to 9-6
Field Built Structures, 9-6, 9-7	Natural Gas, 13-3
	NEC & NESC, 1-12, 1-13, 13-2



## ELECTRIC SERVICE RULES

**INDEX**

**Issued Jan 2024**

---

Number of Services, 1-5  
Operation, 1-1  
Pad Foundation, 4-8 to 4-13  
Pad Mount Transformer, 4-8 to 4-13, 13-11  
Panelized Home, 7-3  
Point of Service, 1-2  
Pole Top Transfer Switch, 8-1, 8-2, 8-16, 8-17, 12-2  
Pools, 4-2, 13-6  
Power Factor Correction, 11-1  
Pre Cut Home, 7-3  
Primary Service Easement, 10-1  
Primary Service Voltage, 10-1  
Primary Service, 10-1  
Purpose, 1-1  
Rewire, 1-3  
Roofs, 1-9, 3-1, 3-3, 3-6, 13-4  
Row-house, 1-2, 1-8  
Rules, 1-1, 1-5  
SCCR, 1-10  
Service Attachments, 3-1 to 3-4  
Service Capacity, 1-13, 2-1  
Service Connections, 1-12  
Service Disconnect Sequence, 1-14  
Service Impairing Equipment, 11-1 to 11-5  
Service Location, 1-3  
Service Mast, 3-1 to 3-4, 13-4  
Service Voltages, 1-4, 10-1  
Services to CATV Companies, 9-1 to 9-10  
Services to Telephone Companies, 9-1  
Short Circuit requirements, 1-10  
Sign, 13-2, 13-3, 13-6  
Special Conditions, 1-6  
Special Services, 11-1  
Standby Systems, 12-1 to 12-6  
Storage Tanks, 13-8  
Switchgear, 4-1, 10-2, 10-6  
Tanks, 13-8  
Temporary Services, 2-1 to 2-7  
Transfer Switch Options, 12-2  
Transformer Location, 13-10 to 13-11  
Underground Installation, 4-2  
Underground Secondary, 4-1  
Underground Service Application, 4-1  
Underground Service Location, 4-2  
Version, 1-12  
Voltages, 1-4, 6-19, 13-1  
Weatherhead, 2-2, 3-1, 3-2  
Welders, 11-1  
Wells, 13-8  
WiFi, 9-1  
Windows, 7-3, 13-12  
Wire Inspections, 1-3  
Word Applications, 1-2  
Zero Lot Line Buildings, 1-2, 1-9



# Typical Underground Single Phase 120/240 Volt Residential Metering Guidelines

## Pedestal Meter Sockets

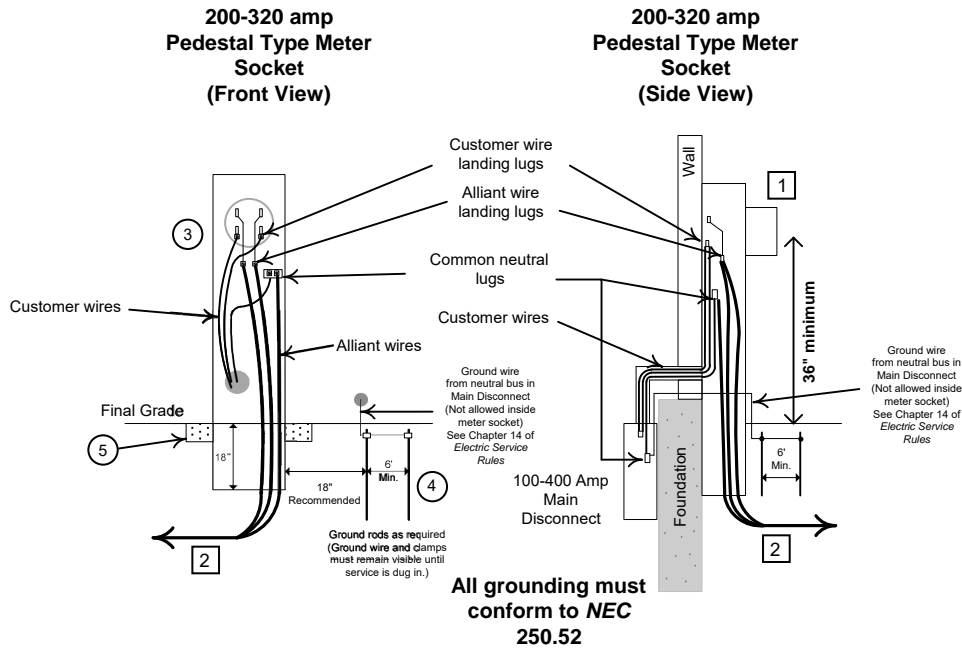

## Standard Meter Sockets

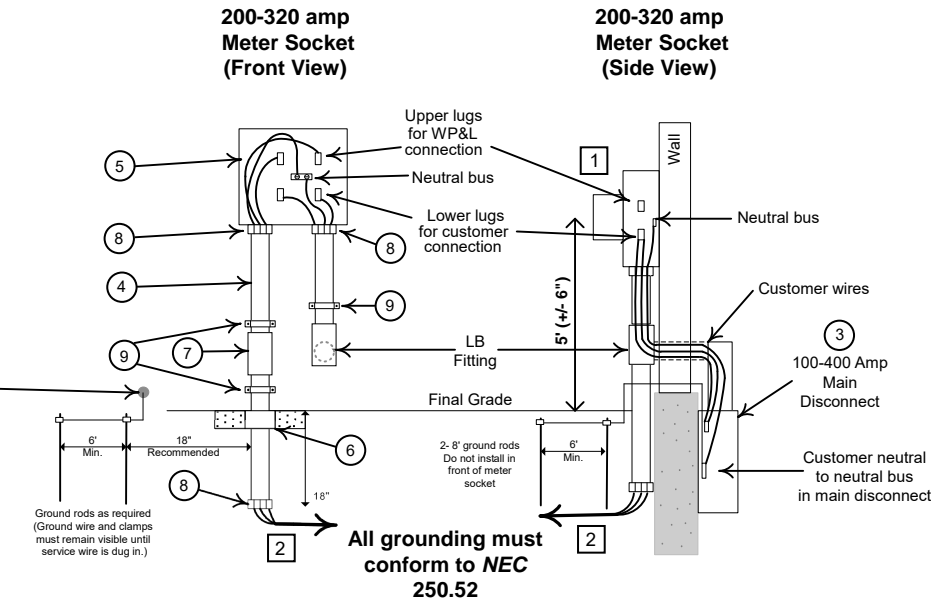

Utility furnishes, installs and maintains

1. Meter
2. Underground service cable

Customer furnishes, installs and maintains

3. Approved meter pedestal
4. Grounding in accordance with the NEC. (refer to Chapter 14 *Electric Service Rules*)
5. Concrete sleeve (encased in concrete)

NOTES:

All underground services 200 amp or less require a 200 amp meter socket.  
IA requires outside disconnect (NEC 230.85)

**See *Electric Service Rules Manual* for additional information**

**See *Electric Service Equipment Book* for approved meter sockets**

**All residential electric installations must be inspected and approved by Authority Having Jurisdiction (AHJ) Contact your State, City, Village or Township**

Utility furnishes, installs and maintains

1. Meter
2. Underground service cable

Customer furnishes, installs and maintains

3. Customer service entrance panel
4. Rigid conduit (Schedule 80 PVC electrical; Galvanized steel or Intermediate metal conduit (IMC)) **2½" for 200A 3" for 300A**
5. Approved meter socket
6. Concrete sleeve (only required if conduit passes through concrete)
7. Conduit expansion joint - Required.
8. Conduit insulating bushing
9. Conduit straps
10. Grounding in accordance with the *NEC* (refer to Chapter 14 *Electric Service Rules*)

This information is only a supplement to the *Electric Service Rules*, *The Electric Service Equipment* and *National Electric Code* books. For complete information about meter sockets and installation go to: [www.alliantenergy.com](http://www.alliantenergy.com)

> PARTNERING WITH ALLIANT > Contractors (Service Manuals) > Electric service manuals  
*Electric Service Rules & Electric Service Equipment*

# Typical Single Phase 120/240 Volt Residential Metering Guidelines

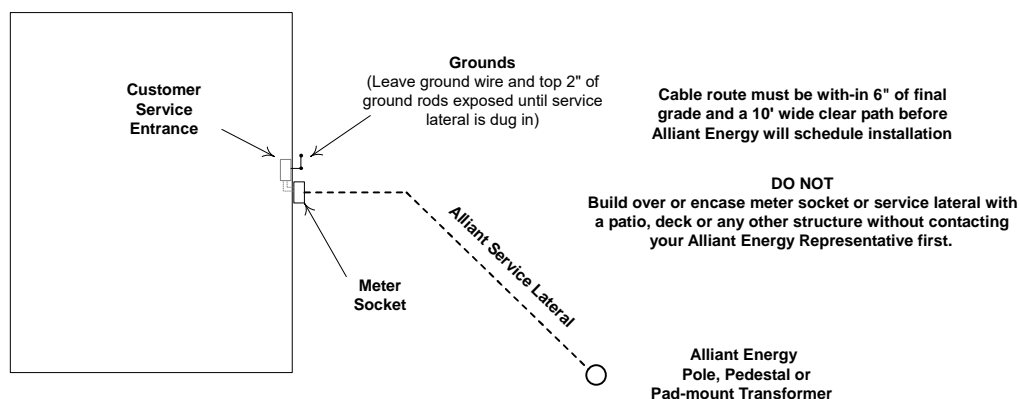

## UNDERGROUND SECONDARY SERVICE

### 401. GENERAL INFORMATION

- A. The underground service lateral is defined as Alliant Energy's underground service conductors from the last pole, pedestal, transformer or other Alliant Energy structure, connecting to the customer's metering point, or termination equipment. Alliant Energy will install, own and maintain the underground service laterals in accordance with applicable tariffs and extension rules. Alliant Energy will not install underground service laterals across rock quarries, tillable agricultural land or other locations not suitable for underground cables and equipment as determined by Alliant Energy.
- B. Alliant Energy will not terminate service lateral conductors inside the customer's building or in customer-owned switchgear. The termination point shall be outside the customer's building in free-standing or wall-mounted equipment, (self-contained meter, metering transformer cabinet, or a termination box). Alliant Energy will not terminate on a customer's circuit breaker or disconnect switch.
- C. Before installing service entrance equipment, the customer shall apply to Alliant Energy for underground service and obtain approval for the service location. The customer shall install, own and maintain all service entrance facilities other than the service lateral, meters, instrument transformers and instrument transformer wiring.
- D. All underground service cables shall be protected from physical damage. See Rigid Conduit in Section 407. Reference: *NEC 230.32, NEC 230.50 & NEC 300.5*
- E. The proposed cable route shall be clear of all obstructions and within 6 inches of final grade before Alliant Energy will install service lateral. A 10 feet wide cable route clear of trees and other obstructions shall be provided by the customer.
- F. Grade changes of more than 6 inches over Alliant Energy's direct buried cables are not allowed.

### 402. SIZING UNDERGROUND FACILITIES

- A. **Conduit** - Number of conduits sized to customer's main disconnect. See Section 407
- B. **Transformer Pad** - Sized to customer's main disconnect. See Section 408 for concrete pad, Section 412 for single-phase box pad and Section 411 for three-phase box pad.
- C. **Underground Conductors** - Sized to customer's load and to meet all voltage drop and flicker requirements
- D. **Transformer** - Sized to customer's load
- E. **Metering Transformer or Termination Cabinets** - Sized to customer's main disconnect

### 403. LOCATION OF ALLIANT ENERGY SECONDARY VOLTAGE CABLES

#### A. Buildings and Pools

Alliant Energy's cables (primary or secondary) shall not be located under buildings or pools. Inform Alliant Energy of plans for future buildings, pools etc.

#### B. Sidewalks, Hard Surfaced Parking Lots, Driveways, Patios and Decks

1. With approval from Alliant Energy, buried cables may be installed in conduit through these areas, if no other acceptable route exists.\*

\*Exception: Cable runs crossing under sidewalks at 90° may not be required to be installed in conduit, unless there are other circumstances that would require conduit.

2. With approval from Alliant Energy, a hard surface may be installed over the existing direct buried cable, provided a conduit with capped ends and tracer/pull wire(s), is/are installed 18-24 inches away and parallel to the existing cable, at a 24-36 inch depth.
3. Conduit, if required, is to be installed by the customer, or at the customer's expense. Services under concrete add conduit to 3 feet beyond edge of concrete.

#### C. COMPLIANCE

Whenever a direct buried cable installation is found to be out of compliance with any of the stated requirements, or in violation of local, state or national codes, the customer's equipment and/or Alliant Energy facilities will be modified at the customer's expense to bring the installation into compliance.

### 404. UNDERGROUND SERVICE INSTALLATIONS

#### A. Services to Meter Sockets

Alliant Energy will install trench and cable for all underground services to self-contained individual meter sockets/pedestals, or a combination of no more than two grouped sockets serving a building. An expansion joint is not required with a vertical only conduit that runs from below ground to the meter socket(s). When a service conductor is installed in conduit(s), such as referred to in 404B, an expansion joint is required. Where conduit runs are used for services the customer shall install a pull string in the conduit at the time of the conduit installation. (Also see drawing 404A and 404B)

#### B. Service Terminating in a Metering Transformer Cabinet

The customer will install trench and service conduit for all services terminated in a group meter assembly or meter-pack of more than two meters, a metering transformer cabinet or a termination cabinet. See 407 for number and size of conduit(s). An expansion joint shall be required for all wall-mount services in this category. For all services with conduit runs, the customer shall install a pull string in the conduit at the time of the conduit installation. Alliant Energy will provide service conductor cables and make all connections. Check with Alliant Energy for conduit size and number required. (Also see drawing 404B)

- C. A building or structure installed on a state approved monolithic slab foundation shall comply with the ESR 404B drawing. Expansion joint(s) and appropriate sized rigid conduit(s) are required at the service point and shall be installed by the customer or their contractor. In addition, conduit(s) shall extend to at least two feet away from the building or structure and shall be installed at the depth required by NEC/NESC. Digging around monolithic slab foundations shall be done by the customer or their contractor.
- D. The customer's service installation shall be in compliance with all requirements of the National Electrical Code (*NEC*) and those of Alliant Energy.

# THREE PHASE TRANSFORMER PAD/METERING GUIDELINES

## 3 Phase Secondary Metering Specification 400A-3000A Single Meter

All metering equipment will be installed outdoors

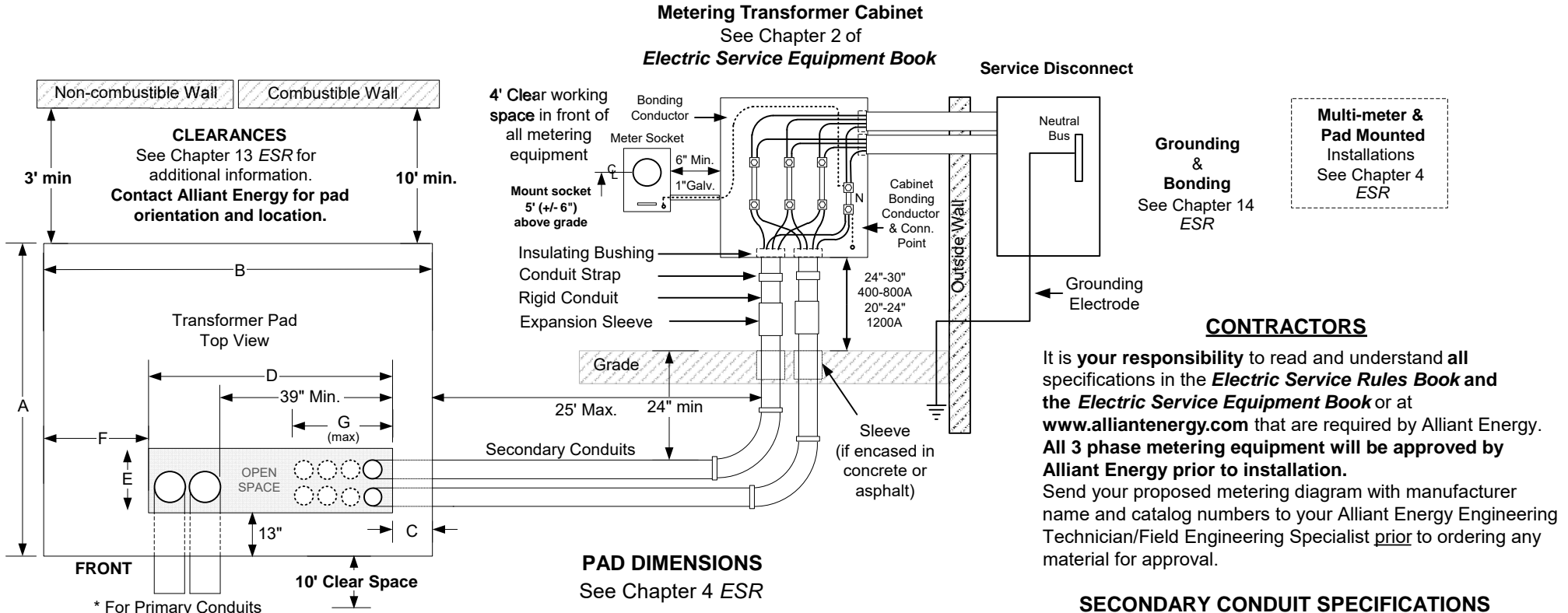

### Contact Engineering for Orientation and Sizing

Alliant Energy Engineering will specify which pad is correct for your installation

#### Typical Installation

(2) 36" or 48", Schedule 40,  
\*PVC 90 degree sweeps,

3 to 4 feet below grade, extending 3' min.  
beyond pad. (Plug and mark both ends)

	120/208v	277/480v	A	B	C	D	E	F	G	PAD THICKNESS
PAD I	100-1200 AMP	100-600 AMP	84"	96"	10"	55"	17"	31"	22"	6"
PAD II	1600-3000 AMP	800-3000 AMP	105"	108"	14"	60"	17"	34"	27"	8"

- Notes:**
- All conduits shall enter through the window opening provided in the pad foundation. These conduits shall be cut off so the top of the conduit is flush with the surface of the pad.
  - All metallic conduits (if installed) shall be fitted with an insulating bushing.
  - When an oil sump is required, excavate 18" under and around the pad and fill with coarse crushed rock - check with local building code to determine if an oil sump is required.
  - Concrete mix shall have a minimum strength of 4000 lb./sq.in. after 28 days.
  - The top of the pad shall be level and all edges and corners rounded off.
  - The pad shall be reinforced with #4 wire, 4" x 4" welded mesh or equivalent materials with additional 3/8 reinforcing rods around the cable opening. The mesh shall not be less than 1" from the edges and opening, and 3" below the surface. If the #4 wire, 4" x 4" mesh is not available, 2 layers of #10 wire, 6" x 6" mesh, staggered by 2 inches horizontally, may be substituted for the #4 wire.
  - CT 1600Amp and greater require Pad mount

Note 1. 1600-3000A Termination & Metering Cabinets are Padmounted Only

Riser Material will be:

**Schd. 80 PVC** (electric rated); **Galv. Steel** or **IMC**  
See Chapter 4 ESR for complete specifications.

## 2024 Summary of Changes:

### Background:

- The Electric Service Rule Team conducts an annual review of the ESR.
- Company employees submit change requests to improve Electrical Services. There were some revisions based on this feedback.

Rule Number	Rule Name	More Info about Edits
103	Codes and Rules	Added Informational Note – <i>Prior to reconnecting service, the service installation shall be approved by Electric Metering and Alliant Energy Engineering. The customer shall (at customer’s expense) provide proof of inspection by a licensed electrician or a local licensed electrical inspector deeming the service safe. A wiring statement/affidavit shall be completed before service is energized. (e.g. Hot socket or damaged equipment)</i>
108	Service Voltages and Maximum Amperage (600 Volt or Less)	Updated Table – Changed “Suercripts” Removed superscript #6 Requires disconnect ahead of the meter-socket that has a maximum SCCR of 10,000 Amps. In order to limit the SCCR, limited to maximum loading on 3 – 50 kVA transformers. Applies to self-contained 480-volt installations. Re-wrote super script #7 now reads” In Wisconsin, new services are underground as a standard. New overhead services by Alliant Engineering approval only.”
109.C.1.A	Secondary Service – Distance Exceptions - Buildings	Updated language – Clarified 150ft rule – “Each of the above distances is measured in a straight line. The distance is measured between utility service terminations.”
109.C.6.B	Three-Phase Service	Updated language – Added “(must be 2000 amps or greater)”
107.F 107.F.4	Electrical Wiring Inspections	Updated language – Changed topic from “Wiring Inspections” to “Electrical Wiring Inspections” Updated language- “If Alliant Energy personnel is on site and notices electrical installation may be unsafe, Alliant Energy reserves the right to request an inspection prior to energizing the customer service.”

Rule Number	Rule Name	More Info about Edits
108	Superscripts	<p>#3 Updated language-“ Limited by loading on 3-167 kVA transformers. <b>May require multiple electric service masts.</b>”</p> <p>#6 Updated language- “Requires disconnect ahead of the meter-socket that has a maximum SCCR of 10,000 <b>Amps</b>. In order to limit the SCCR, limited to maximum loading on 3 – 50 kVA transformers. Applies to self-contained 480-volt installations.”</p> <p>#7 Updated language – “In areas near livestock (within ~ ½ mile), single phase services are limited to the maximum sizes below. Larger single-phase services may be allowed pending Agriculture Representative testing. Additional system upgrades may also allow for larger services. Maximum single phase service sizes. All exceptions shall be <b>forwarded</b> to approved by variance and Agriculture compliance teams <b>for review</b> (Refer to ESR <b>e-manual</b> Chapter 8):”</p>
109	Number of services	Updated language – “Alliant Energy provides each parcel of land or property with only one service (refer to Section 108 for service sizes). Additional services may be permitted with approval from Alliant Energy Engineering. Additional services must meet specific requirements as described in the following sections. Reference: NEC 230.2.”
109.C.3	Electrically Isolated Service Exception	Updated language- “Additional services may be provided to <b>separate buildings</b> or structures, where there are no electrically conductive (i.e. wiring) paths to another service, ( <b>for example Electric vehicle chargers</b> ). . Services provided by this exception are treated according to Alliant Energy’s extension rules.”
114.A	Changes to Existing Service-Entrance Equipment	Updated language- Removed “ <b>version of the</b> ” added “ <b>State adopted version of the</b> ”
114.B	Changes to Existing Service-Entrance Equipment	Updated language- Added “ <b>State adopted version of the</b> ”
116.C	Capacity	Updated language- <b>Changed “will” to “should”</b> . For customer installations of two to six breakers or sets of fuses (service disconnects), on the load side of a termination box or metering transformer cabinet, the sum of the ampere ratings of the circuit breakers or fuses multiplied by 80% <b>will should</b> not exceed the ampere rating of the termination or metering cabinet.

Rule Number	Rule Name	More Info about Edits
118.B.2	Customer Installation	Updated language- Added "the". The Wisconsin State Electrical Code in SPS 316.230(3)(b) states that conduits for service conductor located according to NEC 230.-70(a) can extend no more than 8 feet into the building from the point they enter the inside of <b>the</b> building through the outside wall or concrete floor. (WP&L Only)
201	Overhead Temporary Service, Single-Phase, 3-wire, 120/240 or 120/208volt, 200 Amp Max (for construction sites)	Notes: Added #6 -" <b>Alliant Energy will approve location. Must be accessible by bucket truck.</b> "
205	LARGE TEMPORARY SERVICES, 1PH or 3PH	Updated language- "Changed 100 AMP to 400 AMP" <b>400 AMP – 277/480 VOLTS – THREE-PHASE (FROM POLE XFMR)</b> <b>400 - 1200 AMP – 277/480 VOLTS – THREE-PHASE (FROM PAD XFMR)</b>
302	SERVICE RISER REQUIREMENTS	Added Note #3 <b>"One attachment point with up to three masts going to a raceway or cabinet."</b>
303.D	SERVICE MAST CONSTRUCTION	Updated language- <b>Removed "enclosed portion"</b> . Service masts shall not extend more than 6 feet above any sloped roof. This height is measured from the point where the conduit exits the <b>enclosed portion</b> roof to the top of the weatherhead.
401.D	GENERAL INFORMATION	Removed D <b>"All underground service cables shall be protected from physical damage. See Rigid Conduit in Section 407. Reference: NEC 230.32, NEC 230.50 &amp; NEC 300.5"</b>
401.F	GENERAL INFORMATION	Added F- <b>"Alliant Energy's cables shall not be located under buildings, decks, pools, or structures. Contact Alliant Energy of plans for future buildings, pools, decks, patios, etc."</b>
403.A	LOCATION OF ALLIANT ENERGY SECONDARY VOLTAGE CABLES	Updated language- <b>"Alliant Energy's cables shall not be located under buildings, decks, pools, or structures. Contact Alliant Energy of plans for future buildings, pools, decks, patios, etc."</b>

Rule Number	Rule Name	More Info about Edits
404.A	UNDERGROUND SERVICE INSTALLATIONS	<p>Updated language- Removed “An expansion joint is not required with a vertical only conduit that runs from below ground to the meter socket(s).”</p> <p>Added – “on line and load side”</p> <p>Alliant Energy shall install trench and cable for all underground services to self-contained individual meter sockets/pedestals, or a combination of no more than two grouped sockets serving a building.</p> <p><del>An expansion joint is not required with a vertical only conduit that runs from below ground to the meter socket(s).</del> When a service conductor is installed in conduit(s), such as referred to in drawing 404A and 404B, an expansion joint is required <b>on line and load side</b>. *Expansion joints shall be above final grade. Where conduit runs are used for services the customer shall install a pull string in the conduit at the time of the conduit installation. (Also see drawing 404A and 404B)</p>
405.	OUTDOOR METER SOCKET	<p>Updated language- changed “200 AMP to 300AMP”</p> <p>100 - 300AMP 1-PHASE 120/208 VOLT – COMMERCIAL</p> <p>Table Item #7 Removed -<b>required where horizontal conduit runs are installed</b>”</p>
407 Table Heading	RIGID CONDUIT	Updated language- Removed “25 Feet Max.”
407	Notes	<p>Updated language- Note #3” <b>When a service conductor is installed in conduit(s), such as referred to in drawing 404A and 404B, an expansion joint is required on line and load side. *Expansion joints shall be above final grade. Where conduit runs are used for services the customer shall install a pull string in the conduit at the time of the conduit installation. (Also see drawing 404A and 404B). All Underground conduit runs need to be a minimum 18 inches”</b></p> <p>Added Note #4 - <b>“Commercial services may be restricted to 25 Feet Max check with Alliant Energy engineering.”</b></p>
408.A	CONCRETE PAD SPECIFICATIONS AND LAYOUT FOR THREE-PHASE, PAD-MOUNT TRANSFORMERS	<p>Updated language Removed – <b>“If a service requires more than eight conduits, contact Alliant Energy for details on pad design.”</b></p> <p>Added – <b>“A maximum of 8 secondary conduits are allowed”</b></p>

Rule Number	Rule Name	More Info about Edits
408.B	CONCRETE PAD SPECIFICATIONS AND LAYOUT FOR SINGLE-PHASE, PAD-MOUNT TRANSFORMERS "OPTIONAL"	Added B- <b>New section</b>
408.C	CONCRETE PAD SPECIFICATIONS AND LAYOUT FOR THREE-PHASE, PAD-MOUNT TRANSFORMERS (CONTINUED)	Added Note #6- <b>"If structure is a farm building see Chapter 8."</b>
410	CONCRETE PAD SPECIFICATIONS AND LAYOUT FOR JOINT PAD THREE-PHASE, PAD-MOUNT TRANSFORMER AND METERING TRANSFORMER CABINET "BACK TO BACK DESIGN"	Updated language Removed – <b>"If a service requires more than eight conduits, contact Alliant Energy for details on pad design."</b> Added – <b>"A maximum of 8 secondary conduits are allowed"</b>
5	DISTRIBUTED GENERATION	<b>Renumbered from section 508 until the end of the chapter</b>
508.	Electrically isolated arrays	<b>Added New section" For two PV systems that are electrically isolated, there shall be a minimum distance of 12 feet between the two arrays."</b>
509.B	LABELING REQUIREMENTS	<b>Redesigned "Interconnection" placard</b>
509.E	Labeling Requirements	<b>Added Note E – "Machine engraved with uniform numbers and lettering."</b>
511.A.1	INTERCONNECTION DISCONNECT SWITCH (DISCONNECTION DEVICE) REQUIREMENTS	Updated language- <b>Removed" In Iowa, due to the requirements of the Iowa Administrative Code 199-45, the disconnection device shall be located within 10 feet of the utility electric meter on residential and single building structures. Disconnection device shall be located in an accessible location visible from the electric meter."</b> <b>Added – "Disconnection devices are considered easily visible and adjacent: for a home or business, up to ten feet away from the meter and within the line of sight of the meter, at a height of 30 inches to 72 inches above final grade."</b>



Rule Number	Rule Name	More Info about Edits
511.H	Large Area Facilities with Multiple Buildings fed from main service panel or sub-panel	<p>Renamed Section</p> <p>Updated language- Removed “For facilities with multiple buildings where the DG is installed on a remote building, the lowa distance requirement for the disconnection device is increased to within 30 feet line of sight from the utility electric meter. In lowa and Wisconsin, a permanent placard shall be installed on the meter socket indicating the location of the interconnection disconnect switch and distance in feet from the meter to the disconnection device.”</p> <p>Added – “For facilities covering a large area with multiple or remote buildings that require electric service, the disconnection device may be up to 30 feet away from the meter and within the line of sight of the meter, at a height of 30 inches to 72 inches above final grade. A permanent placard shall be installed at the meter socket indicating the location of the interconnection disconnect switch and distance in feet from the meter to the disconnection device. For example, corporate &amp; college campuses, Industrial facilities, manufacturing facilities, etc.”</p>
Chapter 6	Secondary Metering	Renumbered - Chapter 6 starting at 611 until the end of the Chapter 631.D
609.B	OUTDOOR FREE STANDING (Field-Built) METER STRUCTURES	<p>Updated language- Removed “etc” “Wood field-built structures shall have a minimum of two 6” x 6” wood posts and 2” x 6” planks that are pressure treated against decay per the American Wood Protection Association (AWPA). The posts shall be buried a minimum of 4 feet deep, plumb and set in concrete the full depth. The planks shall be level and fastened with stainless steel or hot-dipped galvanized (G-185) hardware (bolts, washers, nuts, <del>etc.</del>), nails and screws are not acceptable. The customer is responsible for the maintenance of the structure. See ESR 609.dgn for allowable design details.</p>

Rule Number	Rule Name	More Info about Edits
611	277/480 VOLT, THREE-PHASE, UP TO 200 AMPS – OH – SELF CONTAINED – LIMITED TO 10,000 AMPS MAX AVAILABLE FAULT CURRENT	Removed section
611.C	SELF CONTAINED GROUP & MODULAR METERING – CONTINUED Multiple meter positions (2 or more), up to 200 amps per socket, 250V max.	Updated language – Added the word “approved” If the breaker, switch or termination cabinet is not approved by Alliant Energy, a separate <b>approved</b> termination cabinet will be required. The customer will provide the conductors that terminate on the service equipment.
612.4 Note	METERING TRANSFORMER CABINET INSTALLATIONS	Removed “Refer to ESR Section 611 for non-irrigation, OH 277/480-volt services, 200 amps or less, which may utilize self-contained metering.”
612.B	OUTDOOR METERING TRANSFORMER CABINET UNDERGROUND SERVICE (Also see Section 612 for Notes and Requirements)	Table Item #12 Added – “or” “Sleeve/or if conduit passes through concrete or asphalt”
612.C	OUTDOOR METERING TRANSFORMER CABINET UNDERGROUND SERVICE (Also see Section 612 for Notes and Requirements)	Table Item #12 Added – “or” “Sleeve/or if conduit passes through concrete or asphalt”
613.	COMBINED SELF-CONTAINED GROUP & MODULAR METERING AND	Table Item #10 Added – “or” “Sleeve/or if conduit passes through concrete or asphalt” (UG)
Chapter 8	Farm Services	Removed Note from all drawings - <b>**Note: 20 feet is expected. 12-30 feet is allowed when necessary due to physical limitations.</b>
802.C	FARM SERVICE YARD POLE OR STRUCTURE	Updated language – “Locate the transformer <del>20</del> a <b>minimum of 12 feet to a maximum of 30 feet</b> from the customer’s service entrance and any other customer owned structures/facilities for potential neutral isolation requests in the future

Rule Number	Rule Name	More Info about Edits
802.G	FARM SERVICE YARD POLE OR STRUCTURE	Updated language - Alliant Energy requires that all meters be installed so the meter faces an area that is accessible and clear. All meter sockets shall be securely fastened to pole or structure, plywood is not acceptable.
807	OVERHEAD SERVICE TO A FARM YARD-POLE, WITH POLE TOP TRANSFER SWITCH (Site-Isolation Device)	Changed Heading - OVERHEAD SERVICE TO A FARM YARD-POLE, WITH POLE TOP TRANSFER SWITCH (Site-Isolation Device) FOR MAINTENANCE ONLY
1002	UNDERGROUND PRIMARY SERVICE TO SWITCHGEAR	Updated language – Table, Item #4 added “or other revenue meter type” Table, Item #8 Added “if applicable”
1003	OVERHEAD PRIMARY SERVICE (BY VARIANCE) Only allowed when served from existing primary overhead	Updated language – Table, #3 added “or other revenue meter type” Table, #7 added “if applicable.” Table, #8 added “Per NEC 250” Table, #11 Changed “Primary fusing” to “Primary overcurrent protection”
1003	OVERHEAD PRIMARY SERVICE – CONTINUED Only allowed when served from existing primary overhead	Updated language – Under drawing changed “main fuse” to “Primary overcurrent protection device”
1101.A.3	SERVICE IMPAIRING EQUIPMENT	Corrected Date – “519-2014” to “519-2022”
1201.D	SAFETY	Updated language – Added “brass or engraved self-sticking aluminum with a minimum of ¼ inch block lettering. Customer shall install a label at the meter reading “Standby Generation on-site”.”
1202.C	TRANSFER SYSTEM REQUIREMENTS	Updated language – Added “(indoors or outdoors)”
1202.E	TRANSFER SYSTEM REQUIREMENTS	Updated language – Removed “. A circuit breaker may be considered if installed with a locking mechanism and approved by Alliant Energy distribution engineering and metering.”
1202.G	TRANSFER SYSTEM REQUIREMENTS	Added G – “Disconnection device shall be mounted at a height between 30 and 72 inches. Interconnection disconnect switch shall have a minimum of 6” vertical and horizontal separation from all other electrical equipment, non-electrical equipment, and all other obstructions. If these requirements cannot be met, they can be reviewed by Alliant Energy.”

Rule Number	Rule Name	More Info about Edits
1202.E	TRANSFER SYSTEM REQUIREMENTS	Updated language – Removed “. A circuit breaker may be considered if installed with a locking mechanism and approved by Alliant Energy distribution engineering and metering.”
1202.G	TRANSFER SYSTEM REQUIREMENTS	Added G – “Disconnection device shall be mounted at a height between 30 and 72 inches. Interconnection disconnect switch shall have a minimum of 6” vertical and horizontal separation from all other electrical equipment, non-electrical equipment, and all other obstructions. If these requirements cannot be met, they can be reviewed by Alliant Energy.”
1204.G1/G2/H1/H2	Grade Level Automatic Transfer Switches	Put Information in a table format.
1206.B	1-PHASE/3-PHASE, PARTIAL LOAD BACKUP OPTION B	Added – A new option and drawing
1308.B Zone 1	PAD-MOUNT TRANSFORMER LOCATIONS	Updated language – Added “from a combustibile wall. Also, minimum distance for any pad-mounted transformer from a non-combustibile wall.”
1308.B Zone 2	PAD-MOUNT TRANSFORMER LOCATIONS	Updated language – Changed “building” to “wall”
1309	SINGLE-PHASE, PAD-MOUNT TRANSFORMER PROTECTION	Updated language – Added “AND METERING EQUIPMENT” to title.
1310	THREE-PHASE, PAD-MOUNT TRANSFORMER PROTECTION	Updated language – Added “AND METERING EQUIPMENT” to title.